

BP-IMFM 2000

BATTERY POWERED INSERTION MAGNETIC FLOWMETER

*Measurement, data acquisition
and transmission system of flow
and pressure for water networks
with long battery life*

With Battery Powered Insertion Magnetic Flowmeter 2000 (BP-IMFM2000) BM Tecnologie Industriali developed and introduced in Full Pipe Water Flow Measurement Market an innovative **ALL IN ONE** flow meter.

BP-IFM2000 is an electromagnetic flow meter that uses insertion sensor, it is battery powered by a Lithium battery type LiSOC12 lasting up to five years and it can be powered by a 24 VDC power supply too.

It acquires data on an internal 4 Mb memory (200,000.00 acquisitions) and on an external 4GB micro SD card: the acquired data, together with the alarms and the diagnostics can be sent remotely through a built-in GSM / GPRS modem.

The IP68 protection grade of the main unit and the IP68 protection grade of the sensors complete the excellent performances of this flow meter.

The advanced configuration menu can guide in a few steps, through a graphic LCD display and a keyboard or using software HydroFlux, even a few experienced operator about how to use BP-IMFM2000.

A sophisticated diagnostic system, with a smart user interface, allows the user to understand quickly if the measurement is correct and, if not, to identify the problems.

The software HydroFlux was developed for the advanced management of the acquired data, it allows the creation of master data, tables and graphs, it could be able to make the budget in a water district and identify the water losses, it imports and exports the data.

Main Characteristics

- ✓ Flow measurement
- ✓ Optional Pressure measurement
- ✓ Protection IP68
- ✓ Battery life: up to 5 years, expandable up to 10 years
- ✓ Compact and easy to install
- ✓ Data acquisition on internal memory and Micro SD card
- ✓ Data transmission via GPRS/GSM/SMS to a remote system
- ✓ Software "HydroFlux" for data management and configuration

Main Applications

- ✓ Virtual Water Districtualization
- ✓ Leak in Aqueduct
- ✓ Check Fire System
- ✓ Calibration of Numerical Models
- ✓ Measurement campaigns on Long and Short Periods in Aqueduct
- ✓ Water Balance
- ✓ Pumping Station Control
- ✓ Waste Water Treatment Plants
- ✓ Hydroelectric Power Stations
- ✓ Industrial Process Monitoring
- ✓ Billing purposes
- ✓ Flow Surveys
- ✓ Flow Profiling

The basis for the operation of electromagnetic flowmeters are Faraday's Laws of Induction. A voltage is induced in a conductor as it moves through a magnetic field. This measurement principle is applied to a conductive fluid which flows in a pipe through which a magnetic field is generated perpendicular to the flow direction (see Fig. 1). The voltage which is induced in the fluid is measured at two electrodes located diametrically opposite to each other. This signal voltage U_E is proportional to the magnetic induction B , the electrode spacing D and the average fluid velocity v . Noting that the magnetic induction B and the electrode spacing D are constant values indicates that a proportionality exists between the signal voltage U_E and the average flow velocity v . The equation for calculating the volume flowrate shows that the signal voltage U_E is linear and proportional to the volume flowrate.

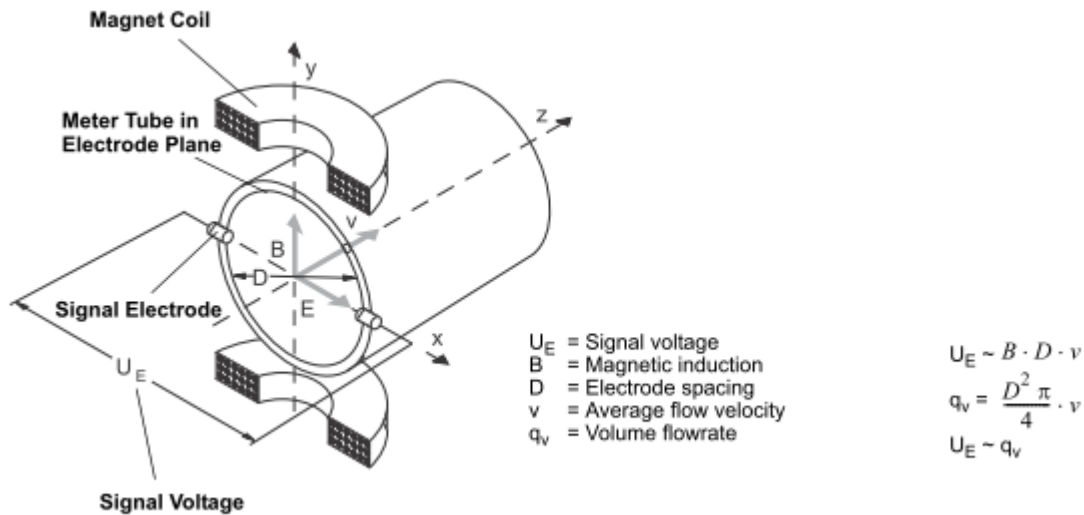

Fig. 1



ELECTRONIC UNIT	
I/O	
Flow sensor inputs	Inputs for electromagnetic sensor
Digital Input	Programmable by the user
Output Signals	<ul style="list-style-type: none"> • Active analogue output 4-20 mA (requiring external 24VDC power); • Digital output for pulses maximum 1000 Hz duty cycle max 50% for instant load, positive only, positive and negative; • Programmable digital output for: <ul style="list-style-type: none"> - Maximum pulses 1000 Hz duty cycle max 50% for negative load; - Negative load indication; - Cumulative alarm • Digital output in active frequency 0-10 kHz (requiring external 24VDC power); • All outputs are opto-isolated. • Pulse outputs with a maximum capacity of $\pm 35\text{VDC}$ 50 mA.
Pressure sensor input	1 analog input 0÷10V
Serial port	<ul style="list-style-type: none"> • IIRDA interface for communicating with laptop or hand held communicator, and dedicated SW for programming, displaying and downloading data. • MODBUS RTU interface on RS 485.
Accuracy	1 % of the read value (minimum velocity 2,0 mm/s)
Repeatability	0.1% of the read value (minimum velocity 2,0 mm/s)
Sampling Frequency	Programmable 5, 3, 1, 1/15, 1/30, 1/60, 1/120, 1/240, 1/480 Hz.
Measuring Stabilization Time	3 seconds
Electrical Conductivity	20 $\mu\text{S/cm}$ minimum
Recommended Velocity	-10 to 10 m/s
POWER SUPPLY	
Internal Battery	<ul style="list-style-type: none"> • Lithium, type LiSOCl₂ • Expected lifetime with working temperature of 0...50°C (32/122°F): <ul style="list-style-type: none"> - Internal battery pack 3-6 years - Internal and external battery pack 6-10 years
External Power source	Low tension: 11÷24V AC/DC
Power Consumption	3 - Watt
ACQUISITION DATA MEMORY	
Flash	4 MB – 200.000 lines of data (one line includes: instant flow, 2 counters, date, time, temperature). Completely programmable both in terms of content and acquisition times.
Micro SD card	4GB
Diagnostics Data Logger	64 kB EEPROM, 2000 lines of data (one line includes: Date, time, temperature, error codes, user actions with changes made). Not programmable and tamper/reset proof.
REAL TIME CLOCK	
Real Time Clock	Buffered with internal battery
MODEM and SIM CARD	
Bandwidth	QuadBand GSM: 900/1800 e 850/1900 MHz
Functions	SMS, GSM, GPRS
Standard	Compatible with controls AT standard 07.07 e 07.05
DISPLAY e KEYBOARD	
Number of characters	<ul style="list-style-type: none"> • Graphic LCD - 128x64 pixels, 50x25mm visual area • Backlit white colour, programmable backlighting. • Simultaneous display of a counter + instant variable + status flags. • Counters with 8 mm high characters for reliable and easy reading. • Programmable display content.
Menu languages	Italian, English, Spanish

BP-IMFM 2000

Technical Features

No. of keys	4 keys
ENVIRONMENTAL	
Temperature	<ul style="list-style-type: none"> • Process: -10°C to 70°C • Ambient: -20°C to 60°C • Storage: -30°C to 70°C
Protection	IP68
PROGRAMMING	
Programming mode	<ul style="list-style-type: none"> • With push buttons on board of converter for non-billing applications. • By IrDA interface and laptop with dedicated software or via RS485 and MODBUS RTU protocol; available for all applications including billing and custody transfer.
MECHANICAL	
Case/Material	Aluminium epoxy painted IP 67/68, with front window in toughened glass.
Size and weight	Cylindrical: Length 249 mm; Diameter 117 mm – Weight 3.5 kg
MEASUREMENT UNITS	
Metric /Imperial	Settable individually for counters, flow indication, pulse emission. <ul style="list-style-type: none"> • Selectable volume units: ml, cl, dl, l, dal, hl, m3 , in3, ft3, gal, US gal, bbl, oz.
COMPLIANCE STANDARDS CE	
Approvals and Certifications	BP-IMFM 2000 unit meets all the requirements established by the EC directives. The manufacturer certifies the success of the qualification tests by applying the CE mark. <ul style="list-style-type: none"> - For Main Unit: <ul style="list-style-type: none"> • Electromagnetic compatibility: Directive 89/336/EEC, EN 61326-1:2006 • Low voltage directive : Directive 2006/95/EC • Custody Transfer : MI-001 and OIML R-49 (certification pending) - For Insertion Sensor: <ul style="list-style-type: none"> • CEI EN 61010-1 • UNI EN ISO 6817 • EN 14154 • EN 50081 - 1

MAIN UNIT DIMENSIONS

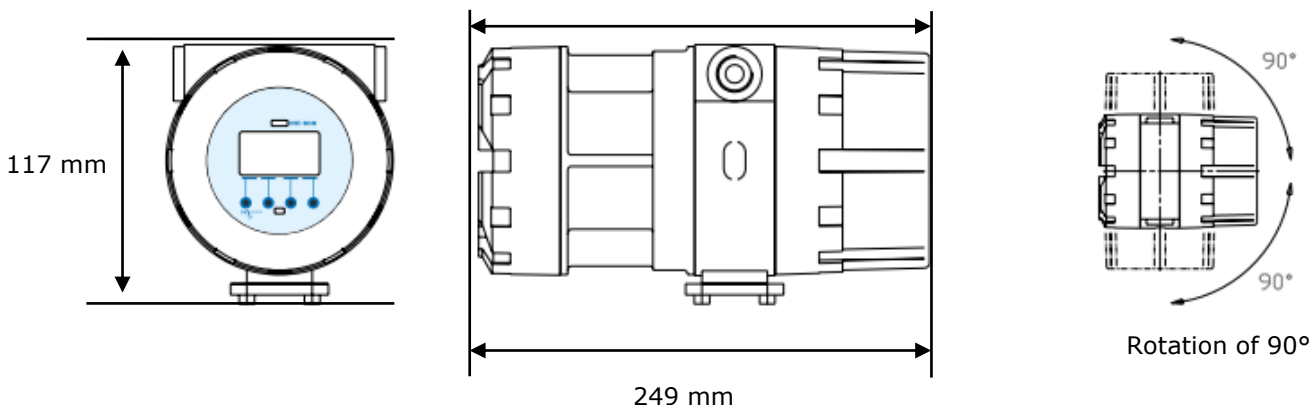

ELECTROMAGNETIC INSERTION SENSOR

Material	<ul style="list-style-type: none"> • AISI 304 stainless steel. It is supplied together with a bronze muff. In the separate version (with cable) they have an IP68 protection degree for immersion in 1.5 meters. <p>The junction box placed on top of the sensor, has two glands for the cables connection. The sensors are available with several lengths, to fit various pipe diameters.</p> <ul style="list-style-type: none"> • The head of the sensors is in PTFE and in contact with the fluid
Electrodes	AISI 316 L stainless steel.
Assembly	<p>Insertion sensors must be installed on empty pipes.</p> <ul style="list-style-type: none"> • For pipes with DN>80 to DN1000 through a 1.1/4" threaded brass muff. • For pipes with DN40 to DN≤80 through a 1" threaded brass muff. <p>(The muff has to be welded to the pipe to which connect the sensor). The probe has to be inserted into the tube for 1/8 of its internal diameter.</p> <p>When installing the sensor, the minimum distances of 10 diameters upstream and 5 diameters downstream must be respected, making a 90° angle with the pipe as per fig. 2.</p>
Total Length	317 mm
Parts in contact with the liquid	<ul style="list-style-type: none"> • Head of sensors in PTFE • Electrodes (to appraise after muff welding) • Pipe end in AISI 304 Stainless Steel
Electric Connections	Cable gland PG11 + Terminal Block + sealing resin
Weight	2 kg
PIPES	
Internal diameter	40...1000 mm
Hydraulic conditions	The upstream straight section must be greater than 10 diameters, the downstream section should be greater than 5 diameters
MEASURED FLUID	
Type	All conductive fluids, minimum conductivity 20 µs/cm ² .
Liquid Temperature	-40°C...+180°C
ELECTROMAGNETIC SENSOR	
Type	Insertion type
Cable length	Max. 10 mt with battery power, Max. 100 mt with 24VDC power supply
Protection	IP68

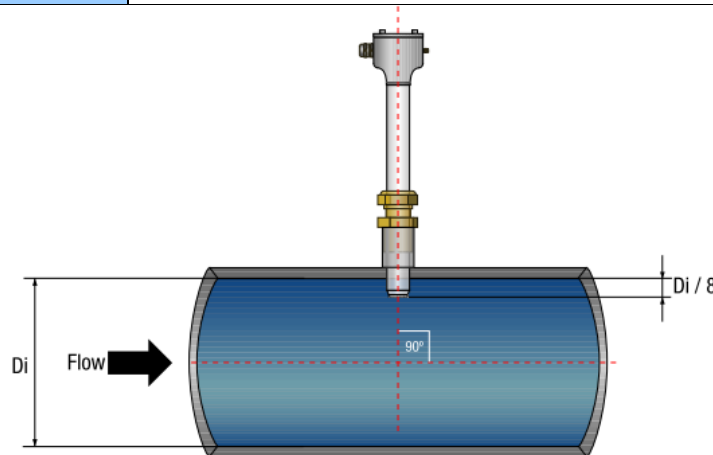
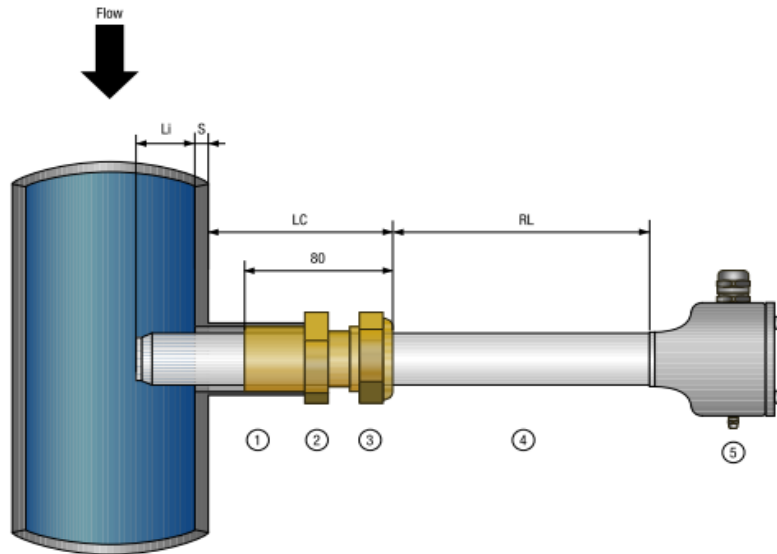

Fig. 2 - Installation

INSERTION SENSOR DIMENSIONS



Overall Dimensions

- 1 - Female Coupling: 1" BSP / NPT for pipes DN40...≤80; 1.1/4" BSP / NPT for pipes DN80...1000 (see below picture)
- 2 - 1.1/4" Male BSP / NPT fixing device for pipe size >DN80; 1" for pipe size < DN80
- 3 - Blocking Nut
- 4 - Insertion Sensor
- 5 - Connection Box
- LC - General length fixing device (to appraise after muff welding)
- RL - Available travel = Ltot - Li - S - LC
- Li - Insertion length = $(De - 2S) / 8$

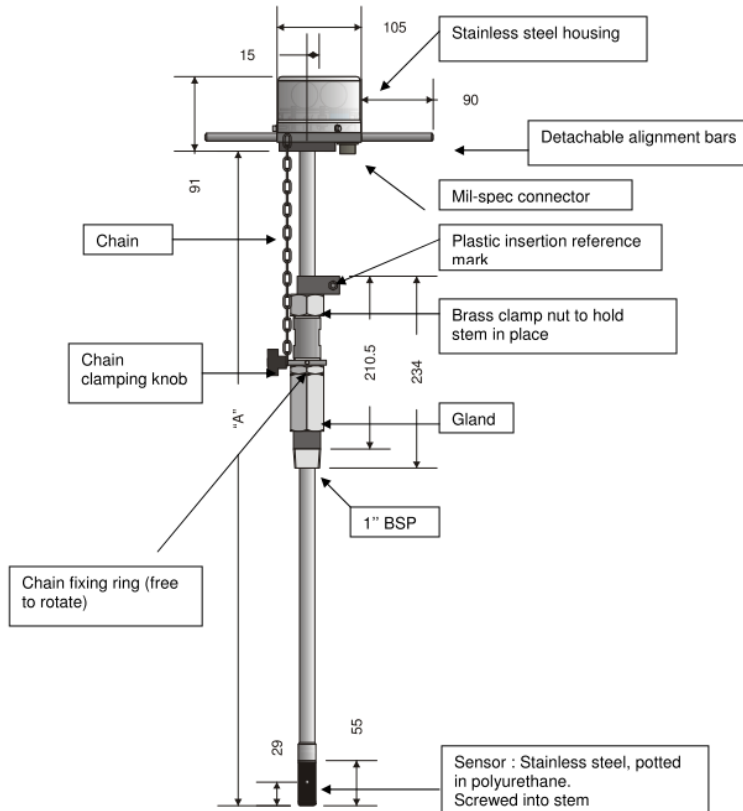

measures in mm

BP-IMFM 2000

Technical Features

PRESSURE MEASUREMENT (OPTIONAL)

Nominal Range	0..0,10 - 0,25 - 0,40 - 0,60 - 1,00 - 1,60 - 0..2,50 - 4,00 - 6,00 - 10,0 - 16,0 - 25,0 - 40,0 - 60,0 - 100,0 Bar (user selectable)
Accuracy	0,5% with a range up to 0,6 Bar - 0,35 % with a range over 0,6 Bar
Temperature	-25°C~ +125°C
Protection	IP68
Cable length	5 m (incremental length at step of 5 m) - Max. 200 m
Engineering unit	Bar, PSI

PRESSURE SENSOR DIMENSIONS



BASIC EQUIPMENT BP-IMFM 2000

Quantity	Description
1	Battery Powered Main Unit
1	Insertion Sensor
1	Pressure Sensor (Optional)
1	Configuration and data management Software: "HydroFlux"
1	User manual

ACCESSORIES and SPARE PARTS FOR BP-IMFM 2000

Description
External battery pack for BP-IMFM2000, type: LiSOC12 Protection IP68
Micro SD card Capacity: 4 GB



ORDERING CODE										
BP - IMFM 2000		1		-		-		-		
Data transmission										
Micro SD card (series)		1								
BlueTooth or RF Module (not yet available)		1								
FLOW SENSOR										
Insertion sensor for pipes from DN40...1000		1								
CABLE LENGHT FOR FLOW SENSOR										
Compact Version (NO CABLE)					0	0				
Indicate the number of 5 m extensions					X	X				
Battery power: max. 10 mt										
24VDC power supply: max. 100 mt										
PRESSURE SENSOR (OPTIONAL)										
NO Pressure Sensor					0	0				
0..0,10 Bar					0	1				
0..0,25 Bar					0	2				
0..0,40 Bar					0	3				
0..0,60 Bar					0	4				
0..1,0 Bar					0	5				
0..1,6 Bar					0	6				
0..2,5 Bar					0	7				
0..4,0 Bar					0	8				
0..6,0 Bar					0	9				
0..10 Bar					1	0				
0..16 Bar					1	1				
0..25 Bar					1	2				
0..40 Bar					1	3				
0..60 Bar					1	4				
0..100 Bar					1	5				
CABLE LENGHT FOR PRESSURE SENS.										
5 m (standard)							0	0		
Indicate the number of 5 m extensions							X	X		



HydroFlux

Software to manage the data downloaded from BP-IMFM 2000
 Data display tabular and graphical form
 Water balance for leaks detection

Software

General description

HydroFlux is a software developed for the configuration, the download and the import of data from BP-IMFM2000 and their following automatic analysis to detect, for example, the losses in a water network.

You can create measurement stations to which bind the data downloaded from a BP-IMFM2000 and build virtual water districts that can be identified by some stations.

The advanced processing and management of ingoing and outgoing flow data of the water districts identifies any losses in water networks by measuring the minimum night flow. It is possible to display the data in tabular or graphical form, for an immediate visualization of trends.

