



# Regulators: CL Series Regulator Installation

---

This document provides installation and start-up instructions for Itron regulator models CL31, CL231, CL34, CL38, and CL838.



**Warning** Follow your company's standard operating procedures regarding the use of personal protection equipment (PPE). Adhere to guidelines issued by your company in addition to those contained in this document when installing or repairing meters.

Follow your company's standard operating procedures regarding the use of personal protection equipment (PPE). Adhere to guidelines issued by your company in addition to those contained in this document when installing or repairing natural gas regulators.



## Safety Notes

- The maximum inlet pressure for this regulator is dependent on the size of the orifice and model designation.
- Non-relief models are limited to 60 psig maximum inlet pressure unless additional safety devices are used as outlined in DOT code OPS, Part 192, Section 192.197.
- Restrict these models to second-stage pressure reduction in the gaseous phase when these models are used on liquid petroleum gases.

## Installation



### Caution

Remove all shipping plugs from the inlet, outlet and vent of any regulator before installation.

Keep piping interior, regulator inlet and regulator outlet free of dirt, chemical sealant (pipe dope), teflon tape, or other debris. Materials in piping or regulator inlet or outlet could cause a loss of pressure control.

Apply pipe joint sealant on the male (exterior) pipe threads. Do not apply pipe joint material on the female (interior) pipe threads of the regulator. Joint materials could lodge in the regulator creating a loss of pressure control.

Gas must flow through the regulator valve body in the same direction as the arrow on the regulator body. Gas flowing in the wrong direction may cause an over pressure condition and damage the regulator.



**Note** The **pilot** diaphragm of CL regulators may be mounted in any position (through a full 360° angle) relative to the regulator body.

## Outdoor Installation

When installing CL series regulators outdoors:

- Always position the regulator's **pilot** vent so moisture (rain, snow) or foreign particles cannot enter the vent opening.
- Itron recommends positioning the **pilot** vent downward to avoid the entry of moisture or foreign materials into the vent.
- Locate the pilot vent away from building eaves, window openings, or building air intakes.
- If applicable, mount the regulator's **pilot** vent above the site's expected snow level.



**Warning** Schedule periodic inspections to check the regulator vent for foreign materials as outlined in DOT PHMSA-RSPA-2004-19856.

## Indoor Installation

When installing CL series regulators indoors, pipe the vent to outside atmosphere using:

- The shortest pipe length
- The fewest possible pipe elbows
- A pipe diameter equal to the vent size (or larger)



**Warning** Using a vent pipe smaller than the vent connection will limit the regulator's internal relief valve capacity. Protect the pipe's outlet end from moisture and the entry of foreign materials. Specify the correct vent size and pipe threads to make the regulator's vent pipe connection.

## Start-up Procedure

### *To start-up the CL series regulator*

1. Mount a pressure gauge downstream of the regulator to monitor the downstream pressure.
2. With the downstream pressure valve closed, slowly open the inlet valve. The outlet pressure should rise to slightly more than the set-point.
3. Verify there are no leaks and all connections are tight.
4. The regulator was preset at the factory to match order specifications. If necessary, adjust the outlet pressure by removing the seal cap on the top of the **pilot** spring housing and adjusting the ferrule or screw inside the **pilot** spring housing using a large flat-head screwdriver. With a small amount of gas flowing through the regulator, rotate the **pilot** ferrule clockwise to raise the outlet pressure or counter-clockwise to lower the outlet pressure.
5. Replace the seal cap and check for leaks after the desired outlet pressure is achieved.

The regulator is ready for operation.

### *To remove the diaphragm case*



**Warning** Adhere to these instructions when assembling or disassembling the main diaphragm case and the valve body. Failure to follow these instructions could damage the valve seat or body gasket.

1. Verify the gas is shut off to and from the regulator.
2. Remove the seal cap (1) from the main diaphragm case.
3. Unscrew the lock nut (2). Secure the flats on the end of the top stem (3) with an open end wrench to prevent the stem from turning while removing the lock nut.

4. Remove the closing spring (4).
5. Remove the control line assembly (5) from the valve body and **pilot** regulator.
6. Unscrew the retainer plate screws (6).
7. You may now safely remove the case assembly from the valve body.

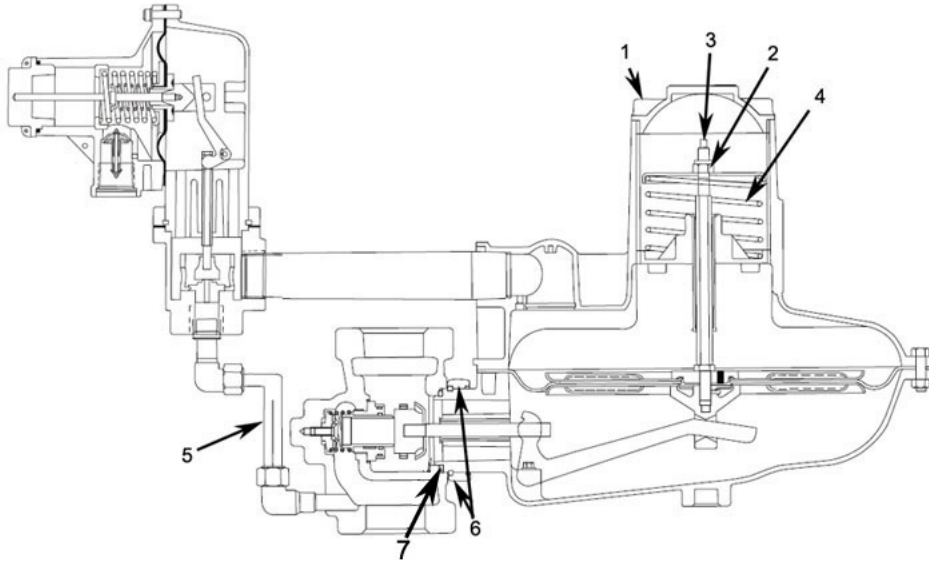

8. To reassemble the diaphragm case, carefully replace the valve body gasket (7) to the position shown. Reverse steps 1 through 6 in the preceding instructions. Verify all connections are secure before turning on the gas to and from the regulator.

Itron is a registered trademark of Itron, Inc. © Itron, Inc. All rights reserved 05 October 2015  
For technical support, contact Itron Support Services.  
Toll free phone: 877-487-6602 Email: support@itron.com