



OCM Pro CF



Dial device

Help



Creating connection



With worldwide TCP/IP
communication !

OCM Pro CF

High accurate Flow
Measurement in
Channels, part filled
and full Pipes as well
as in Flumes and
Surface Water Bodies

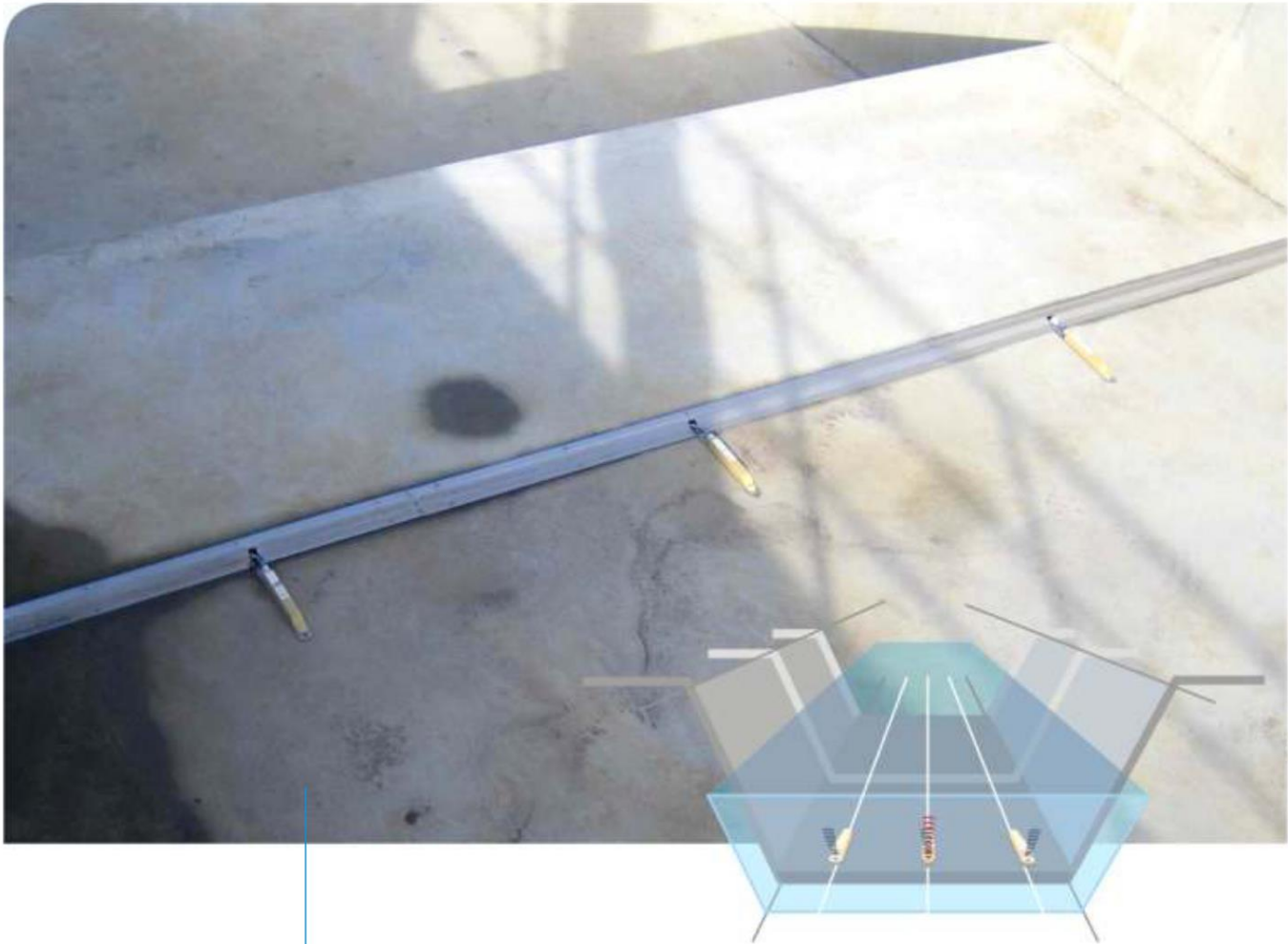

New in the Flow Measurement Area

NIVUS flow measurement technology stands for innovation and high accuracy.

The new OCM Pro CF is a permanent measurement system for continuous flow measurement, flow control and storage of recorded data in a range from slight to heavily polluted media of various consistencies.

It is designed for use in part filled and full pipes, channels and flumes with many different shapes and dimensions.

The OCM Pro CF is equipped with fast processors and offers online access via the Internet. This ensures more versatile, more reliable and more economic operation.



Overview on Transmitter Details

- very high accuracy
- measures the real flow velocity profile
- spatial allocation of single velocities
- cross correlation with digital pattern detection
- absolutely stable zero point and drift-free
- no electrodes, no conductivity required
- measures in all channels, part filled and full pipes and flumes
- measures in heavily polluted and abrasive media
- no external calibration required
- suitable even for very difficult applications
- easy installation without additional constructions
- Ex approval for zone 1 as ATEX
- very easy parameter setting in multilingual dialog mode
- large, back-lit graphic display
- stores complete measurement data on Compact Flash card
- worldwide TCP/IP communication
- online connection/data transmission and remote maintenance via Internet



Lift-up mechanism for inspection purposes or for sensor removal under operational conditions

Sensors - high accuracy and universal use

A complete OCM Pro CF measurement place consists of a transmitter and appropriate active sensors. There are flow velocity sensors with and without integrated flow level measurement available as well as air-ultrasonic flow level sensors for direct connection to OCM Pro CF. Various constructions can be used depending on the kind of application. You can select from wedge sensors for installation in channels and open flumes or pipe sensors for installation in steel, concrete and plastic pipes.

- no modifications or additional constructions at place of installation
- triple redundant level measurement (air-ultrasound, water-ultrasound, hydrostatic)
- measurement dynamics between 5 mm/s and 6 m/s
- measures in both flow directions
- highly medium-resistant standard sensors (PPO, PEEK, 1.4571, Hastelloy C276)
- sensors resistant to chemicals for highest demands
- cables can be extended without any problems
- Ex approval zone 1 as ATEX
- protection rating IP 68

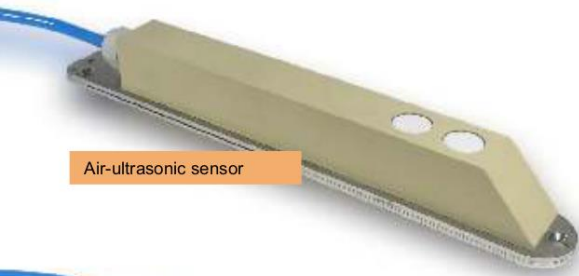

Air-ultrasonic sensor

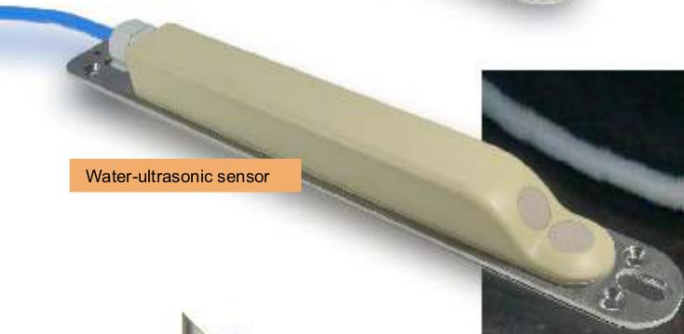

Water-ultrasonic sensor



Pipe sensor

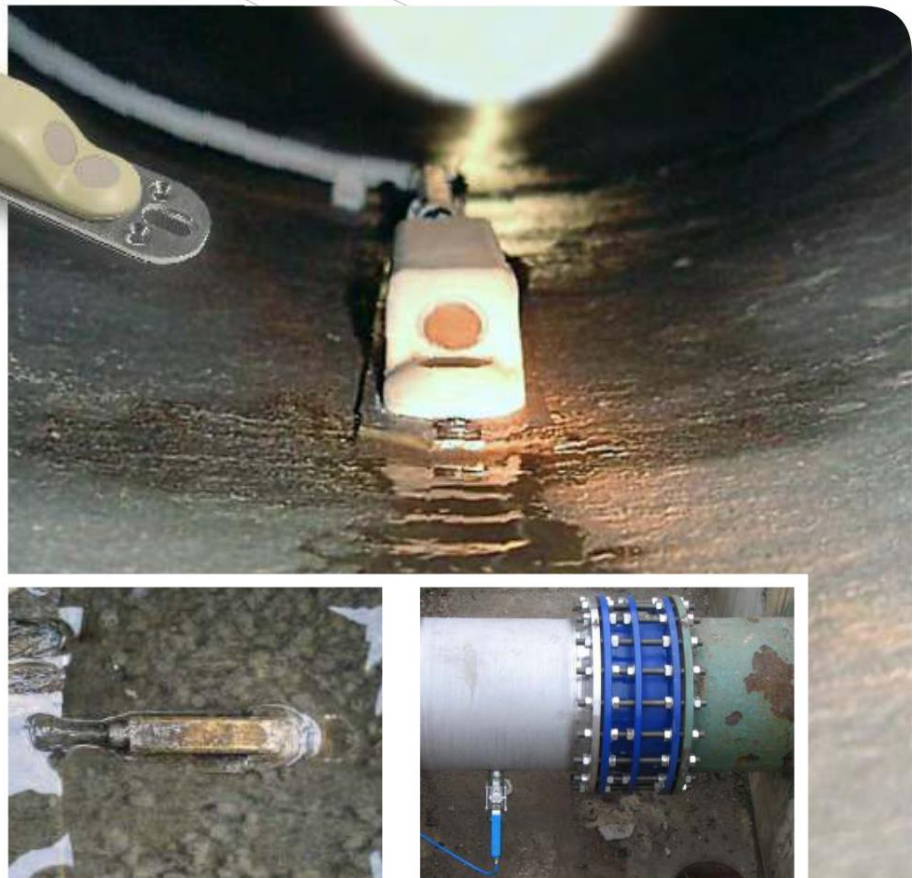

The wedge sensor operates absolutely reliably despite heavy soiling.



Simple pipe sensor mounting.

Successful in use anywhere

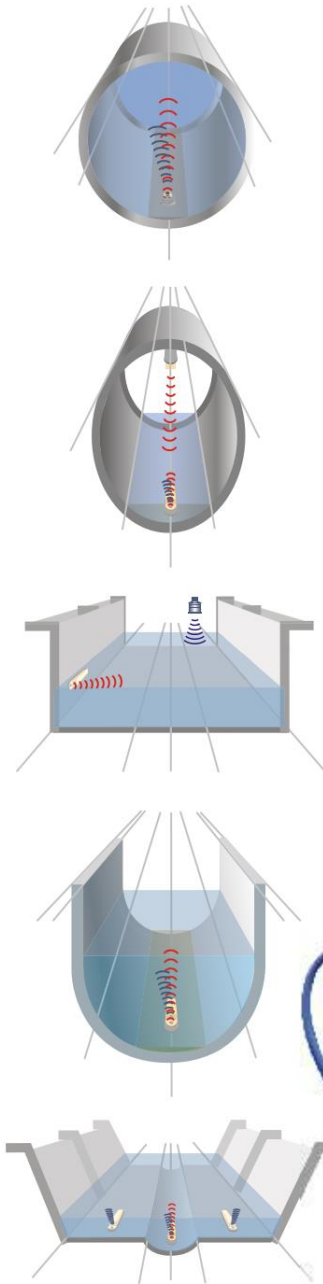

Flow measurement in rectangular channel of a sewage treatment plant

Due to heavy vorticity 3 sensors have been installed. Since initial start-up in December 2001 the measurement runs without interruption.

Standard sensor installed on a wedge

Due to heavy sedimentation in the channel it was necessary to install this special construction. The measurement operates reliably since initial installation.



Measurement in a full filled recirculation line

A full filled recirculation pipe is on the ground of a constantly filled denitrification tank. The measurement in the filled tank was desired to be accessible at any time. The flow velocity sensor has been installed in a guiding tube with a length of 8 m.

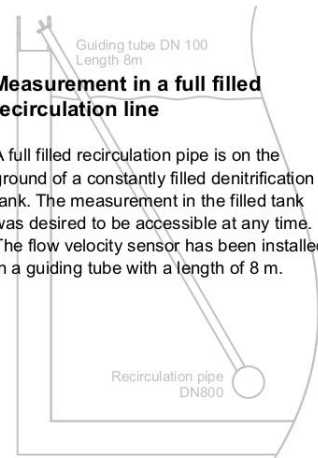

Typical areas of use for OCM Pro CF

- wastewater treatment plants: inlet, discharge, inlet to aeration tanks, return sludge, recirculation, surplus sludge, discharge from digester and flocculant dosing point
- permanent measurements on storm water basin, storm water retention basin, storm water sedimentation tank
- direct discharger control, investigation of extraneous water or leakage
- industrial wastewater networks
- industrial flow measurements
- irrigation systems
- inlets and outlets conducting cooling water or circulation systems
- sluice stages in rivers
- hydroelectric and thermic power plants
- measurement campaigns in channel networks
- MCERTS applications
- and many more

NIVUS - the perfect Solution for each Application



Due to decades of experience and knowledge of our engineers and technicians almost impossible applications are our challenge. If desired, you can let us do the complete planning and evaluation of your measurement place.

Exemplified measurement tasks:

A flow measurement which is insensitive to soiling and sedimentation without the need to be cleaned frequently. The measurements shown in the examples have been developed in order to reliably and accurately detect flow levels considering fluctuations of sludge layers.

In this case OCM measurements with combi wedge sensors have been used which e.g. were placed on the water surface by using vertically movable "floats".

The prevailing water level down to the

sludge surface is going to be detected by using the ultrasonic transit time method.

The flow velocity sensor thanks to the cross correlation provides the accurate flow velocity profile and hence an accurate image of the flow conditions and the flow velocity in the channel.

You need an individual solution for your measurement problem or you are interested in more application examples and references?

Just talk to us.

How the OCM Pro CF measures

The quantity >>flow "Q"<< cannot be measured directly.

The following general equation is the basis for OCM Pro CF flow calculation:

$$Q = A \cdot \bar{v}$$

A = wetted cross-sectional area

\bar{v} = average flow velocity

A is going to be calculated from the cross-sectional area and the **flow level (h)**. The measurement method applied to determine the **flow velocity (v)** is based on the ultrasonic reflection principle.

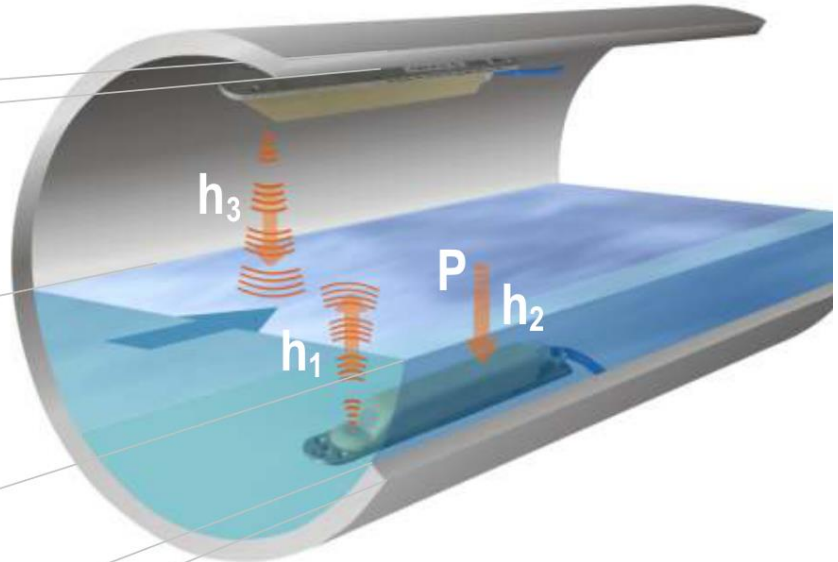

Flow Velocity Measurement (h)

The flow level will be determined by using integrated and / or external sensors.

Based on the ultrasonic echo sounding principle the flow height (fill level) is either going to be measured from the bottom up [h_1] in the medium or from top down [h_3] using air-ultrasound.

The interface between water and air

(water surface) will be detected in both cases and the sound transit time between sensor and water surface is going to be measured.

This method stands out for its accuracy and long-term stability. Foam or any other substances on the water surface do not affect the measurement result. In conditions where liquids are strongly absorbant or the combi sensor is off-set it is possible to measure the fill level by using an optionally available built-in hydrostatic measurement [h_2].



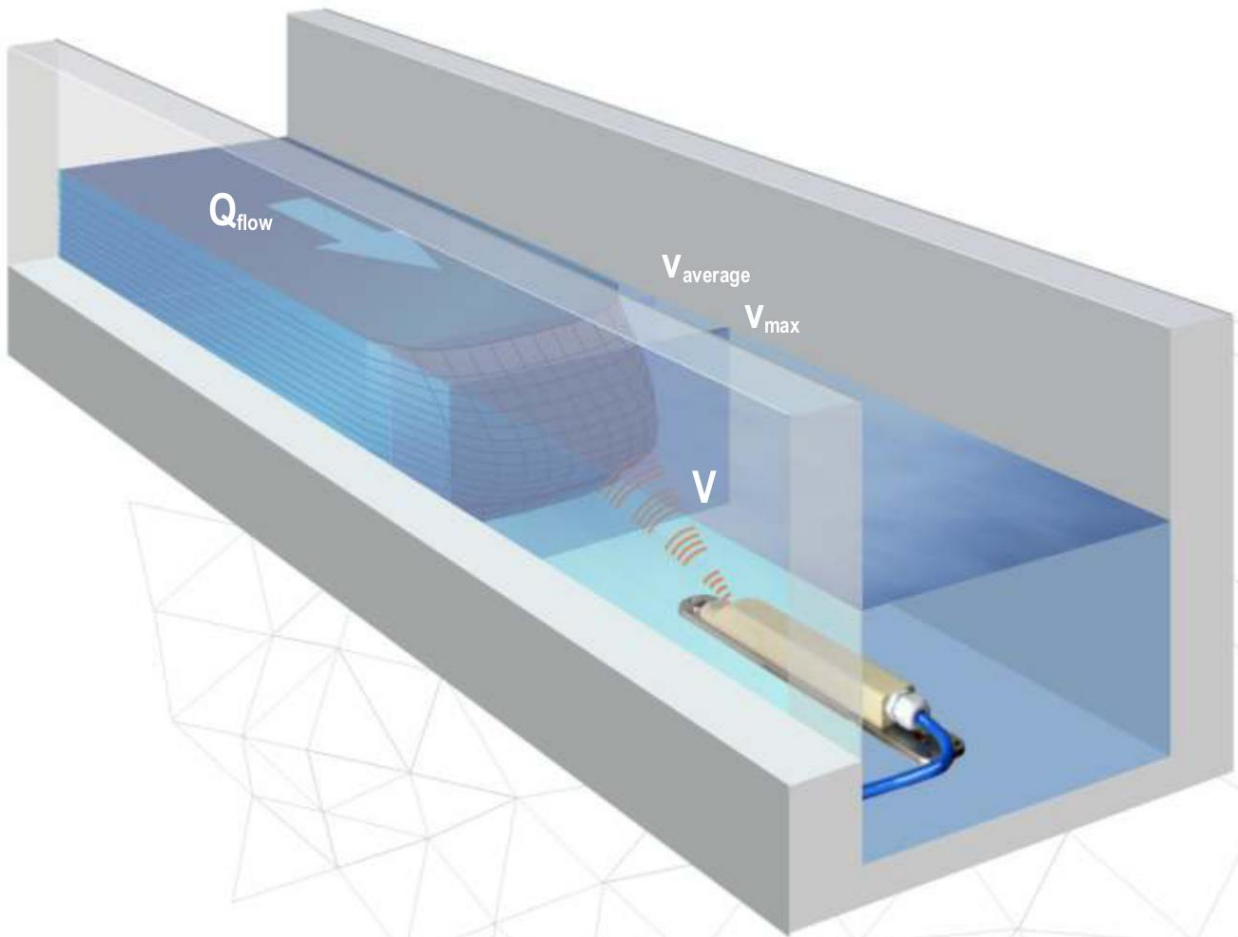

Solar



GPRS



Flow Velocity Measurement

The OCM Pro CF in conjunction with the new combi sensors has the ability to carry out high accurate flow measurements.

The principle of flow velocity determination is based on the ultrasonic reflection principle. One of the latest and most efficient methods for flow velocity detection is the correlation method (interrelation between two similar image patterns). A prerequisite for being applied is the existence of reflecting particles (solids, minerals or gas bubbles) in the fluid.

This allows to exactly allocate the measured velocities spatially and to indicate the results.



... thanks to Cross Correlation

An ultrasonic converter (sensor) sends an ultrasonic burst into the medium.

The particles or gas bubbles in the medium reflect this impulse.

The sensor operates in impulse-echo mode, i.e. the ultrasonic converter will switch to receiving mode immediately after transmitting the burst, receiving the reflected ultrasonic echo as a characteristic echo image pattern.

A spatial allocation can be derived thanks to the transit time of the ultrasonic impulse and the sound velocity.

These echo patterns from the **first scan** will be digitised and saved.

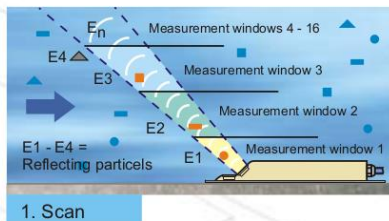

During the **second scan**, an ultrasonic burst will be sent again and the reflected echo pattern will be saved as well.

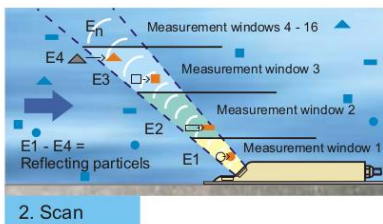

By using the **cross correlation method** the characteristic echo image patterns within the time slots are now checked for compliance.

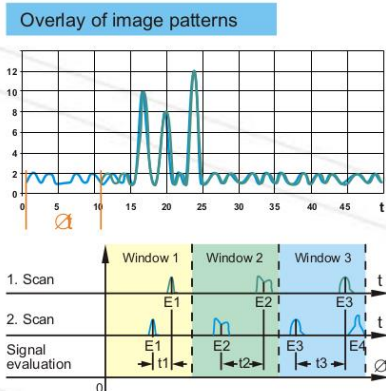

Formula

$$\varphi_{fg}(\tau) = \lim_{T \rightarrow \infty} \frac{1}{T} \int_{-T/2}^{+T/2} f(t) \cdot g(t + \tau) dt$$

This procedure will be repeated up to 2000 times per second. The flow profile will be determined from the individual velocities in real time by the integrated digital signal processor (DSP).

This allows the user to obtain measurement values with the highest accuracy without additional calibration.

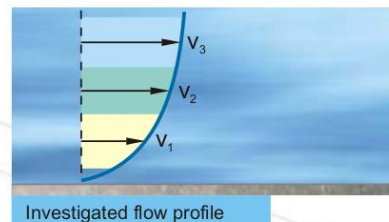

The temporal shift between the echo image patterns from both scans is going to be investigated.

This comparison allows to directly convert the flow velocities prevailing within the single measurement windows considering the beam angle.

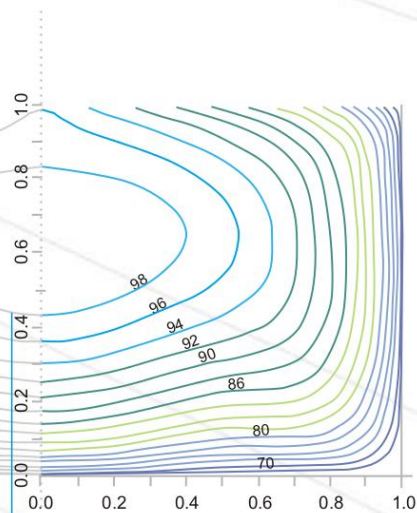

Flow profile directly indicated on the display.



Values can be read directly on the display.



Always up-to-date



Operation / Programming

It is very easy to put the system into operation and to recall data since the large graphic display is clearly laid out for its various applications.

Settings are clearly indicated on the graphic display. This virtually eliminates faulty programming.



The clear program structure allows to easily set parameters.

Data Storage

Any of the recorded readings as well as up to 4 additional external analog signals can be saved in free intervals if the OCM Pro CF has been equipped with a Compact Flash card. Data can be read and evaluated easily.

Diagnostics

The status of analog and digital inputs can be indicated and recalled directly. System failures or irregularities which might have occurred will be recorded as well.

Versatile diagnostic options enable the choice of the best possible measurement place and error free operation of the measurement system.

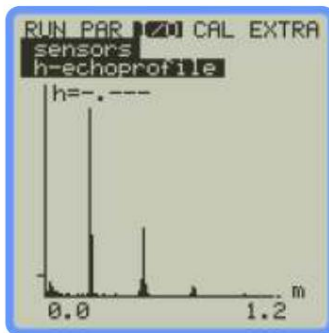

Recall the most important system data on-site or comfortably on PC.

Evaluation

The OCM Pro CF comes with the free evaluation software **NivuDat** which, besides using other common spreadsheet applications, allows the indication of measurement data such as graphs or tables under Windows XP / Windows 2000 quick and clearly.

This ensures the read-out of saved raw data very reliable. Additional processing functions such as sequential data export, averaging, output of min. and max. values, measurement place management and more complete the program.

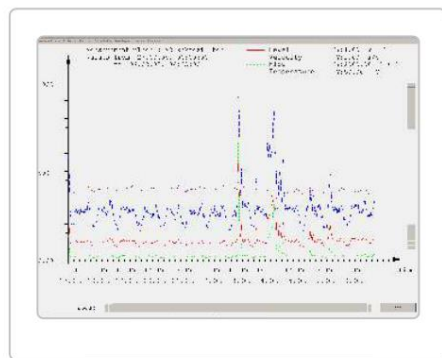



On-site from anywhere

- complies with worldwide interface standard using TCP/IP Ethernet
- integrated web server
- online access via Internet browser without the need to install additional software
- integrated data logger up to 128 MB
- saved data can be read out via Internet at any time
- operation and parameter setting online (remote control)
- quick and comprehensive remote diagnosis of entire measurement place (online service)

The OCM Pro CF offers innovative communication options for remote maintenance, remote diagnosis and data transfer as standard. This is how to interconnect the latest measurement technology worldwide at any time.

Using its integrated web server the OCM Pro CF provides a dedicated web-site using TCP/IP. Besides being used within internal networks this option allows the user to connect the unit to the world wide web. Due to the specially designed operating system the unit is absolutely resistant to virus attacks.

The screen indicated is equal to the on-site display.

Data can be transferred simply by one mouse click. Internet connection enables the user to maintain, control and analyse several measurement places from anywhere in the world simultaneously.

Remote control options enable to access any functions which are available on site.

Visit www.nivus.com and check out communication with our new OCM Pro CF

Integrated Web Server

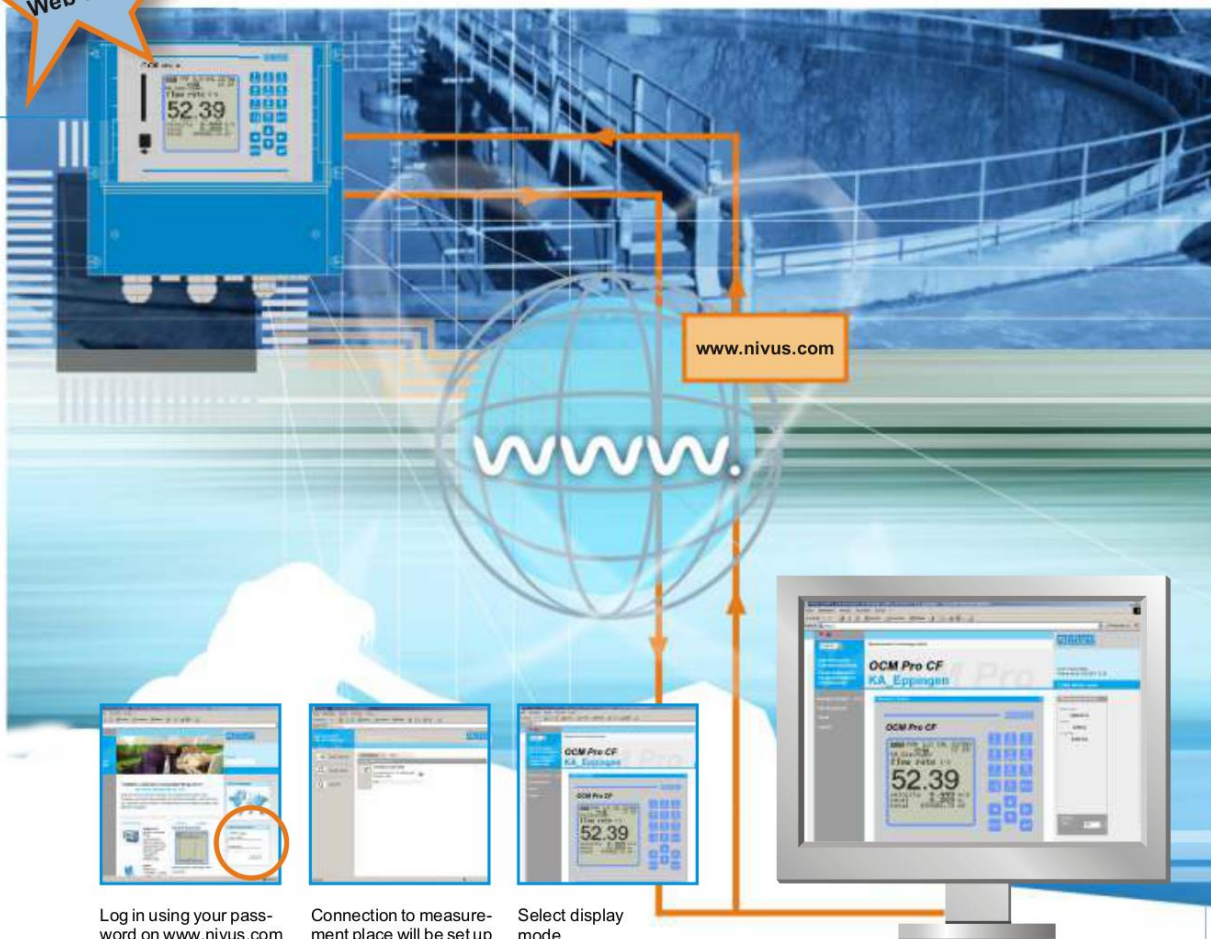

Log in using your password on www.nivus.com

Connection to measurement place will be set up

Select display mode



Specifications

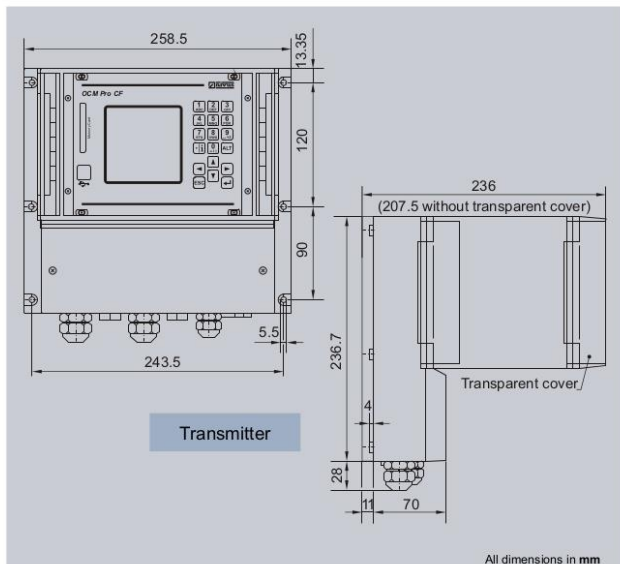

Transmitter

Supply power	100 to 240 V AC, +10 % /-15 %, 47 to 63 Hz or 24 V DC ± 15 %, 5 % residual ripple
Power consumption	max. 20 VA
Material/Weight	Polycarbonate, approx. 3400 g
Protection	IP 65
Ex Approval	II(2)G [Ex ib] II B
Operating temperature	-20 °C to +50 °C
Storing temperature	-30 °C to +70 °C
Max. Humidity	80 %, non-condensing
Display	back-lit graphic display, 128 x 128 Pixel
Operation	18 button keypad, menus in German, English, French, Italian, Spanish, Polish, Danish, ...
Inputs	1 x 4 - 20 mA for external level 1 x RxTx-Bus for NIVUS air-ultrasonic sensor Type LUS up to 4 x 0/4 - 20 mA with 12 bit resolution for external level, external setpoints and data storage up to 4 digital inputs up to 3 velocity sensors
Outputs	up to 4 x 0/4 - 20 mA, load 500 Ohm, 12 bit resolution, up to 5 relays/SPDT
Data memory	Compact Flash Card up to 128 MB
Storage cycle	1 to 60 minutes
Data transmission	Compact Flash Card, TCP/IP via Ethernet and modem (GPRS, ISDN, analog)
Connection	Modbus TCP and TCP/IP via Ethernet and modem (GPRS, ISDN, analog)

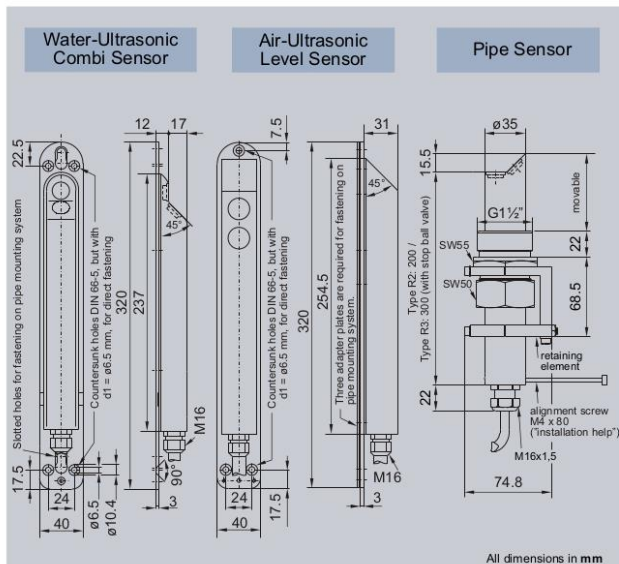

Sensors

Measurement principle	ultrasonic transit time (level/height) piezoresistive pressure meas. (level/height) correlation with digital pattern detection (flow velocity)
Measurement range (v)	-1 m/s to +6 m/s
Measurement range (h)	pressure 3.5 m; ultrasonic 2 m
Measurement frequency	1 MHz
Protection	IP 68
Ex Approval	II 2 G Ex ib IIB T4
Operating temperature	-20 °C to +50 °C (-20 °C to +40 °C in Ex Zone 1)
Storing temperature	-30 °C bis +70 °C
Measurement uncertainty	deviation less than 1 %, (in case of compliance with specific conditions)
Operational pressure	max. 4 bar (combi sensor with pressure measurement cell max. 1 bar)
Cable length	max. 100 m, other lengths on request
Sensor types	V100 flow velocity sensor (v; temperature) V1H1 combi sensor (v meas., level meas. using water-ultrasound and temperature meas.) V1D0 combi sensor (v meas., level meas. using pressure and temperature meas.) V1U1 combi sensor (v meas., level meas. using water-ultrasound and redundancy using pressure and temperature measurement)
Constructions	wedge sensor for installation on channel bottom pipe sensor incl. retaining element for installation in pipes
Materials	Polyurethane, stainless steel 1.4571, PPO GF30, PA (only wedge sensor), HDPE (only pipe sensor)
Option	PEEK, Hastelloy C276 ground plate; Titanium ground plate; FEP-coated cable