



Limitamp[®] Medium Voltage Motor Control

2400-7200 Volts
Application and Selection Guide



imagination at work

GE Limitamp® Medium Voltage Motor Control

Contents

The General Electric Limitamp motor control center provides an economical means of centralizing motor starters and related control equipment. It permits motor control starters, feeders, isolator switches, distribution transformers, interlocking relays, programmable control, metering and other miscellaneous devices to be obtained in a single floor-mounted structural assembly fed from a common enclosed main bus.

Limitamp motor control centers are constructed of standardized heavy gauge vertical sections housing vertical and horizontal buses and compartmented starters. Sections are bolted together to form a single line-up assembly. The entire center may be powered by incoming line connection at a single point. When possible, Limitamp motor control centers bear UL section and unit labels.

| | |
|----------|---|
| A | General |
| B | Controllers |
| C | 5kV Load-Break Switches |
| D | Incoming Line |
| E | Enclosures |
| F | Protection & Control |
| G | Components |
| H | Application Data |
| I | Elementary Diagrams |
| J | Guideform Specifications, Basic Starter Features |

GE Limitamp® Medium Voltage Motor Control

General

GE manufactures and provides full support for the following types of medium voltage controllers:

Table A.1 Product Scope

| Controllers | Design Layout | | Construction | |
|---------------------------------|---------------|--------|--------------|--------|
| | 1-High | 2-High | Welded | Bolted |
| CR194 Stationary Vacuum 800 amp | X | | X | |
| CR194 Drawout Vacuum 800 amp | X | | X | |
| CR194 Stationary Vacuum 400 amp | X | | X | |
| CR194 Stationary Vacuum 400 amp | | X | | X |
| CR194 Drawout Vacuum 400 amp | X | X | | X |

Limitamp control is designed to meet NEMA ICS 3, Part 2 and UL 347 requirements. Various enclosure types and constructions are available and there is a broad selection of modifications for complete control and protection of motors used on modern power-utilization systems with high available short-circuit currents.

Applications

CR194 Vacuum Limitamp control is a high-interrupting capacity, high-voltage control applied to distribution systems rated 2400, 4160 or 4800 volts (7200-volt starters are available in limited applications.) It is used throughout industry to control and protect squirrel-cage, wound-rotor and synchronous motors. It can also be used to feed transformers and other power-utilization circuits.

Typical applications are in paper, steel, cement, rubber, mining, petroleum, chemical and utility-type industries. Limitamp control is also used in water and sewage plants and public buildings for air conditioning, pumps and compressors.

Because of its flexibility, other uses for Limitamp equipment have become common. Some of these uses are:

- Limitamp lineup consisting of a fused isolating switch ahead of four NEMA Class E2 Limitamp controllers, the first three being used as motor controllers and the last as a transformer feeder.

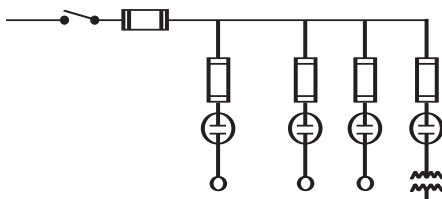

- Limitamp lineup similar to last three units in the preceding description. The transformer, 480-volt motor controllers, and lighting transformer are included in an integrated Limitamp design.

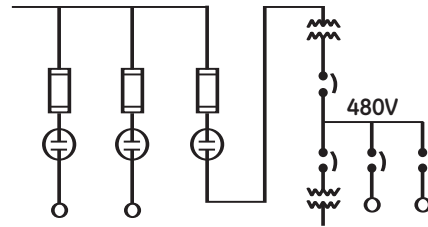

- Limitamp lineup consisting of a reversing isolating switch ahead of a NEMA Class E2 Limitamp motor controller.

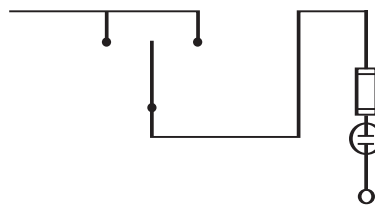

- Limitamp lineup consisting of two NEMA Class E2 Limitamp motor controllers, each having interrupting ratings per Table B.1.



CR194 control is designed for operation on the following power systems.

Table A.2

| System Distribution Voltage | Maximum Motor Hp ^③ | |
|--|---|----------------------|
| | Induction, Wound-rotor Synchronous (0.8 PF) | Synchronous (1.0 PF) |
| CR194 400 Ampere stationary and drawout | | |
| 2400 | 1600 ^① | 2000 ^① |
| 4200 | 2800 ^① | 3500 ^① |
| 4800 | 3200 ^① | 4000 |
| 7200 | 4800 ^① | 6000 ^① |
| CR194 800 Ampere stationary | | |
| 2400 | 3200 ^② | 4000 ^② |
| 4200 | 5600 ^② | 7000 ^② |
| 4800 | 6400 ^② | 8000 ^② |

^① Based on 400 amperes RMS maximum, enclosed, NEMA 1, vented one-high

^② Based on 800 amperes RMS maximum, enclosed, NEMA 1, vented one-high

^③ For non-vented enclosures, apply a factor of 0.8 to the maximum horsepower

GE Limitamp® Medium Voltage Motor Control

General

A

Comparison of Controller Types

Full Voltage Non-Reversing

The Limitamp control across-the-line (FVNR) controller is the most popular type of controller. In general, high-voltage systems have fewer power restrictions than low-voltage systems; therefore, full-voltage controllers may be applied to a greater number of applications. Full-voltage controllers provide lowest cost, simplicity, minimum maintenance and highest starting torque.

Reduced Voltage

Primary reactor (closed-transition) Limitamp controllers (RVPR) are the most popular of the reduced-voltage type starters because they provide a simple, low-cost means of obtaining reduced-voltage starts. The starting time is easily adjustable in the field.

Limitamp closed-transition auto-transformer controllers (RVAT) provide higher starting torque efficiency and a more favorable power factor during starting than a primary reactor starter. The transition time can be easily adjusted in the field. NEMA medium-duty reactors and autotransformers with 50-, 65- and 80-percent taps are provided as standard.

Limitamp solid state controllers (RVSS) are available for applications requiring very tightly controlled motor torque and acceleration times and where avoidance of sudden switch-on of inrush current is desired. RVSS controllers offer several advantages over FVNR controllers:

- RVSS reduces mechanical stress on driven equipment and motor linkage while maximizing torque capability of the motor
- RVSS provides for special stopping requirements of motor/pumps (soft stop/eliminating water hammer effect, etc.)
- RVSS minimizes voltage fluctuations on weak power distribution systems, reducing undervoltage supply to critical loads or causing light flicker
- RVSS may reduce utility demand penalties

GE's RVSS controllers can be programmed for a variety of soft start/soft stop parameters; upon reaching normal run conditions, the controller automatically transfers the load to a fully rated NEMA bypass contactor. They also provide state-of-the-art, built-in motor protection, including:

- Electronic overload
- Ground fault
- Phase loss, phase unbalance, and phase reversal
- Over/under current (including loss of load)
- Over/under voltage
- Optional RTD Input

Among the metering values provided by GE's RVSS are:

- Percentage full load amperage (FLA)
- Phase current
- KVAR
- KVA
- KW
- Ground fault current
- Thermal capacity to start
- Remaining thermal register
- Frequency

Reduced Inrush

Reduced voltage controllers provide a means of reducing the starting inrush where the starting duty is not limited by the controller. This type of controller can be used where extremely long acceleration times are required.

Table A.3 Comparison of Starting Characteristics

| Starter | Starting Characteristics Expressed in Percent Rated Value | | | | |
|--|---|---------------|-----------------|--------|-------------------|
| Type | Voltage on Motor | Motor Current | Line Current | Torque | Torque Efficiency |
| Full Voltage | 100 | 100 | 100 | 100 | 100 |
| RVSS (Solid State Starter with infinitely variable volts) | | | | | |
| 80 percent volts | 80 | 80 | 80 | 64 | 80 |
| 65 percent volts | 65 | 65 | 65 | 42 | 65 |
| 50 percent volts | 50 | 50 | 50 | 25 | 50 |
| "X" percent volts ^② | X | X | X | Y | X |
| Autotransformer (RVAT) | | | | | |
| 80 percent tap | 80 | 80 | 64 ^① | 64 | 100 |
| 65 percent tap | 65 | 65 | 42 ^① | 42 | 100 |
| 50 percent tap | 50 | 50 | 25 ^① | 25 | 100 |
| Primary-Reactor (RVPR) | | | | | |
| 80 percent tap | 80 | 80 | 80 | 64 | 80 |
| 65 percent tap | 65 | 65 | 65 | 42 | 65 |
| 50 percent tap | 50 | 50 | 50 | 25 | 50 |

^① Autotransformer magnetizing current is not included in listed values. Magnetizing current is usually less than 25 percent motor full-load current.

^② X = % of rated RVSS output volts, Y = (X/10)²

Transformer Feeders

Limitamp controllers are generally considered motor starting equipment; however, they are not strictly limited to motors and can provide very good protection for loads such as transformers.

Transformers that can be controlled by Limitamp controllers must have a primary rated in the 2400- to 7200-volt range.

To adequately protect a transformer, it is necessary to define specific protection requirements. The following areas will be considered:

1. Transformer winding fault (primary and secondary)
2. Single-phasing, resulting in a phenomenon known as "ferroresonance"

GE Limitamp® Medium Voltage Motor Control

General

3. Transformer overload

These functions are basic only and are not intended to be comprehensive. Ground fault, differential, fault pressure, undervoltage, etc., are often required and may also be added to a given control. In addition, a transformer controller must allow for transformer inrush current and not cause a nuisance trip-out from a momentary line-voltage dip.

Transformers must be protected from primary and secondary (winding or downstream) faults. In Limitamp controllers, current-limiting fuses are applied to protect the transformer from a primary winding fault, as well as faults in the conductors from the controller to the transformer. The fuses are selected to clear high-magnitude fault currents at the first fault half-cycle and allow the contactor to energize a transformer without operating on inrush currents. (Inrush currents occur when transformer is energized, typically 8-12 times rated amperes for 0.1 seconds). GE Type EJ-2 current-limiting fuses may be applied when used with an overcurrent relay that is chosen to coordinate with the EJ-2 fuse and protect the transformer from damage as a result of a fault in its secondary circuit.

Protection

To determine a basis for protection, refer to ANSI transformer short-circuit ratings, which define the magnitude and duration of downstream faults that a transformer can withstand without damage. A relay would have to be set to operate before the damage point is reached. Base ratings, impedance and the connection of the primary and secondary windings of the transformer must be supplied in order to arrive at the relay setting. The relay for this purpose can be an electronic overload relay.

A common problem with single-phased transformers is a phenomenon known as ferroresonance, which can occur when an unloaded or lightly loaded transformer sustains an open conductor in its primary circuit. Ferroresonance causes system overvoltage as a result of the transformer core inductance forming a “tuned” circuit with the system distributed capacitance. To avoid ferroresonance, all three lines must be switched simultaneously as with a medium-voltage contactor. However, if one line fuse blows, then single-phasing will occur. To prevent this, the medium-voltage contactor may be supplied with a contactor tripping mechanism that operates from a striker pin located in the fuse. When the fuse element burns in two, the spring-loaded striker pin is released. It projects upward and operates a contact that trips the contactor. This feature, known as blown fuse trip, would provide positive

transformer protection from single-phasing due to blown fuses.

Transformer feeders typically are applied on critical process applications where it is important to maintain continuity of operation through a system voltage disturbance. Mechanically latched contactors allow the contactor to remain closed during a disturbance. Like circuit breakers, latched contactors are opened either manually or by means of a shunt trip solenoid.

Capacitor Feeders

Limitamp 400 amp contactors are ideally suited for capacitor switching applications. (Note: 800 Amp is not rated for capacitor switching.)

Capacitors may be switched with the motor, but maximum rating for this function must be determined by motor design.

When the capacitors are provided in Limitamp control, they are normally mounted in an auxiliary enclosure beside the Limitamp controller. A capacitor rated up to 200 KVAR can be mounted in the top of a two-high CR194 enclosure with the controller in the bottom.

Transformer & Capacitor Feeders

Table A.4 is a listing of switching capacities for both transformer and capacitor loads.

Table A.4 CR194 Vacuum Switching Capacities (One-high)

| 8-hour Open Rating (Amperes) | System Voltage | 3-Phase Transformers (kVA) | 3-Phase Capacitors (kVAR) |
|------------------------------|----------------|----------------------------|---------------------------|
| 400 | 2400 | 1600 | 1200 |
| | 4160 | 2800 | 2100 |
| | 4800 | 3200 | 2400 |
| | 7200 | 4800 | 3600 |
| 800 | 2400 | 3200 | N/A |
| | 4160 | 5600 | |
| | 4800 | 6400 | |

Future Starters

Future squirrel-cage, full-voltage non-reversing starters can be installed in two-high construction only when factory-prepared space has been purchased with the original Limitamp equipment.



GE Limitamp® Medium Voltage Motor Control

General

A



Figure A.1 Medium Voltage Compartments in CR194 two-high design



Figure A.2 Medium Voltage Compartments in CR194 one-high design

The purchase of factory-prepared space provides a space unit equipped with vertical power bus, complete interlocking and isolating mechanisms, operating handle and high-voltage door. It does not include electrical components.

When parts are purchased to fill a future starter, these consist of a contactor, power fuses, control power transformer, CPT fuses and fuse supports, current transformers, and low-voltage panel and devices.

Table A.5 Publication References for Limitamp Equipment

| <u>Publication</u> | <u>Description</u> |
|--|---|
| CR194 Vacuum Design | |
| GEH-6263 | 2-high Maintenance Instructions |
| GEH-5305 | 1-high Maintenance Instructions |
| GEH-5396 | 800 Amp 1-high Maintenance Instructions |
| GEF-8016 | Contactor Renewal Parts |
| GEH-5306 | Contactor Maintenance Instructions |
| Fuses and Overload Relay Curves | |
| GES-5000 | Power Fuse and Overload Relay Curves |
| General Purpose Controls | |
| GEP-1260 | Control Catalog |
| Pilot Devices | |
| GEA-10877 | CR104P Push Buttons and Pilot Lights |
| Relays and Timers | |
| GEH-4115 | CR120B AC Relays |
| GEH-4120 | CR120B Latched Relays |

GE Limitamp® Medium Voltage Motor Control Controllers

CR194 Vacuum Stationary & Drawout

Features

- **Easily removable contactor** — The stationary or drawout contactors can easily be withdrawn by removing easily accessible bolts. Front access to the coil and tip wear checks will substantially reduce the need to remove the contactor in normal circumstances.
- **400 or 800 Ampere Contactor** — Vacuum Limitamp control meets the varying needs of industry including today's higher horsepower requirements.
- **NEMA rated** — Vacuum Limitamp control is fully rated and designed to meet the requirements of NEMA ICS 3, Part 2 Class E2 controllers.
- **UL rated** — Vacuum Limitamp control is fully rated and designed to meet the requirements of UL 347.
- **Self-contained power bus** — Vertical power bus is a standard feature of Vacuum Limitamp control. Horizontal power bus is available within the standard 90-inch height and lines up with that of previous Limitamp designs. The power bus ratings have capacity for extended lineups and larger starter requirements.
- **Installation ease** — Provision for cable runs from the top and bottom; easily accessible terminals and small overall size make installation fast and easy.
- **Proven reliability** — Vacuum Limitamp control utilizes the latest vacuum interrupter technology for long, reliable service.
- **Simplified construction** — The operating mechanisms inside Vacuum Limitamp control have been simplified for further improvements in reliability and ease of maintenance.
- **Cooler operation** — The reduced power losses of vacuum interrupters, coupled with other design improvements, provide a controller that is cooler operating to further enhance service life.
- **Quick-make quick-break non load-break disconnect** — Disconnection of the starter from the main bus is accompanied by a quick-make quick-break non load-break disconnect switch. This switch improves the overall control integrity by eliminating the need to rack out the contactor to isolate the load from the power bus.
- **Viewing window** — The switch is equipped with a viewing window for visual assurance that the disconnect contacts are open, and a full barrier for personnel safety. When the plunger on the handle is depressed, the CPT secondary is (isolated) disconnected, which drops out the contactor coil. Then, when the handle is thrown to the "off" position, the CPT primary and the high voltage compartment are isolated from line power.
- **Dependable performance** — Vacuum Limitamp control is coordinated to provide the required motor protection functions and offer reliable overcurrent protection against the damaging effects of overloads and short circuits.

Interrupting Ratings

The interrupting ratings of the controllers vary with the value of the utilization voltage. The following table depicts typical NEMA E1 (unfused) interrupting ratings for Class E1 controllers.

Table B.1 NEMA Class E1 Interrupting Ratings

| Contactor Type and Rating | Interrupting Rating rms symmetrical (MVA) | | | |
|---------------------------|---|------------|------------|------------|
| | 2400 Volts | 4200 Volts | 5000 Volts | 7200 Volts |
| CR193B Stationary 400 Amp | 25 | 43 | 50 | 75 |
| CR193D Drawout 400 Amp | 25 | 43 | 50 | 75 |
| CR193C Stationary 800 Amp | 37 | 65 | 75 | - |
| CR193E Drawout 800 Amp | 37 | 65 | 75 | - |

In addition to normal motor protective relays, NEMA Class E1 Limitamp control must include instantaneous overcurrent relays to signal the contactor to open on fault current. NEMA Class E1 Limitamp control may be employed on systems having available short-circuit currents up to the interrupting rating of the contactor.

Relaying, metering, ground fault protection and lightning arresters are typical of available modifications.

NEMA Class E2 Limitamp control incorporates the high-interrupting capacity of fast-acting fuses. These current-limiting fuses protect both the connected equipment and control against the high short-circuit current available from modern power systems. (See Table B.2.)

Table B.2 NEMA Class E2 Interrupting Ratings

| Contactor Type and Rating | Interrupting Rating rms symmetrical (MVA) | | | |
|---------------------------|---|------------|------------|------------|
| | 2400 Volts | 4200 Volts | 5000 Volts | 7200 Volts |
| CR193B Stationary 400 Amp | 200 | 350 | 400 | 600 |
| CR193D Drawout 400 Amp | 200 | 350 | 400 | 600 |
| CR193C Stationary 800 Amp | 200 | 350 | 400 | — |
| CR193E Drawout 800 Amp | 200 | 350 | 400 | — |

Vacuum Contactors

The vacuum contactors supplied with vacuum Limitamp are of the magnetically held type. They are fully rated at 400 or 800 amperes in accordance with NEMA and UL standards. The contactors differ in size, weight and method of termination. The vacuum interrupters are also different among the various models and are not interchangeable due to their different current ratings, and variations in interlock and wire harness mounting.

The contactor may be serviced in each of the designs available. This allows easy access for normal maintenance — such as vacuum interrupter wear checks and replacement of the operating coil — without removing the contactor. The only time the contactor needs to be removed is to replace a vacuum interrupter at the end of its service life.

GE Limitamp® Medium Voltage Motor Control Controllers

The standard contactors for industrial motor starters are closed by a single magnet and are held closed by the same magnet. This contributes to simplicity of mechanical design and increases the mechanical life of the contactor. Standard contactors may not need adjustment or mechanical repair for many years, primarily due to mechanical simplicity and sturdiness. However, preventive maintenance checks at least once per year are recommended.

Low voltage on the contactor operating coil of an electrically held contactor will cause the contactor to open. For most motor applications, it is desirable to disconnect the motor from the line when the system voltage is lost or lowered appreciably; therefore, the electrically held contactor is appropriate. The DC operating coil of the contactor is designed to be used with a holding circuit to limit coil current. The contactor coil is designed for use on 115 volts rectified AC or 125 volts DC.

For all NEMA Class E1 controllers, the contactor must be capable of interrupting the available short-circuit current. For these applications, instantaneous overcurrent relays must be used to interrupt the contactor coil current. See Table B.3 for additional technical specifications on the vacuum contactor.

Table B.3 Vacuum Contactor Technical Specifications

| Ratings | CR193B CR193D | | CR193C CR193E |
|--|---------------------------------|---------------------------|---------------------------------|
| | Rated voltage (Volts) | 5000 | 7200 |
| Rated current (Amperes) | 400 | | 800 |
| Short circuit interrupting current (kA) symmetrical | 6.0 | 6.0 | 9.0 |
| Class E1 MVA | 50 | 75 | 75 |
| E2 MVA | 2400 volts | | 200 |
| | 3600 volts | | 300 |
| | 4160 volts | | 350 |
| | 4800 volts | | 400 |
| | 7200 volts | | 600 |
| Short-time current (amperes) | 30 seconds | | 2400 |
| | 1 second | | 6000 |
| Impulse withstand (kV) | 60 | | 60 |
| Dielectric strength 1 minute (kV) (Power frequency dielectric test) | 13.25 | 18.2 | 13.25 |
| Vacuum integrity test (AC RMS) | 20 kV | | 20 kV |
| Switching frequency (Operations/hour) | 360 | | 360 |
| Mechanical life (Operations) | 2 x 10 ⁶ | | 1 x 10 ⁶ |
| Electrical life (Operations) | 1 x 10 ⁶ | | 0.25 x 10 ⁶ |
| Closing time (mS) | 350 | | 270 |
| Opening time (mS) (Switched on DC side of rectifier) | Consult Factory | | Consult Factory |
| Pick-up voltage (% of rated) | 85% min | | 85% min |
| Drop-out voltage (% of rated) | 10 - 65% | | 10 - 65% |
| Control voltage (Volts) | 115 rect. AC | | 115 rect. AC |
| Control circuit burden (VA) | Closing | | 175 |
| | Hold-in | | 30 |
| Auxiliary contacts ^① | 20 maximum (N.O. or N.C.) | | 20 maximum (N.O. or N.C.) |
| Ratings | Current (amperes) | 10 | 10 |
| | Voltage (volts) | 600 | 600 |
| Switching | AC | 6 amperes at 600 volts | 6 amperes at 600 volts |
| | DC | 1 ampere at 240 volts | 1 ampere at 240 volts |
| Contactor weight lb (kg) | 77 (35) | | 114 (52) |
| Applicable standards | UL 347 NEMA ICS 3, Part 2 | | UL 347 NEMA ICS 3, Part 2 |

GE Limitamp® Medium Voltage Motor Control Controllers

① Limited to 10 in two-high starter.

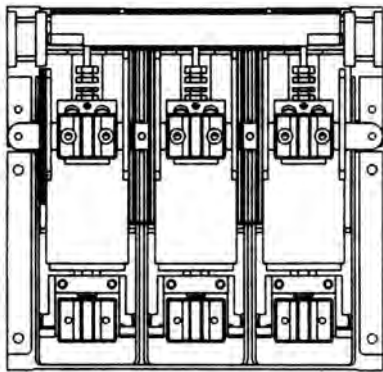

Figure B.1 View from Interrupter Side

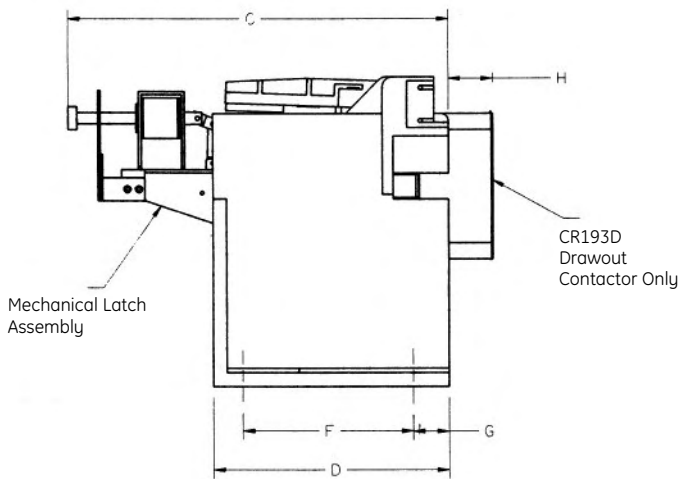
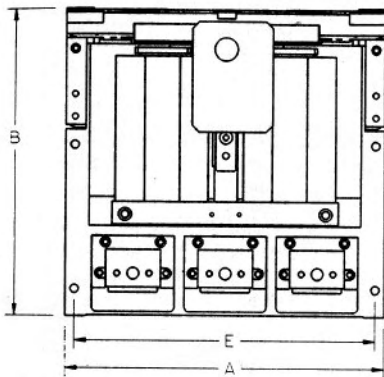

Figure B.2 Coil Side and Side Views

Table B.4 Contactor Dimensions in (mm)

| Key | CR193B | CR193D | CR193C | CR193E |
|-----|-------------|-------------|-------------|-------------|
| A | 14.88 (378) | 14.88 (378) | 18.90 (480) | 18.90 (480) |
| B | 13.50 (343) | 13.50 (343) | 16.93 (430) | 16.93 (430) |
| C | 14.65 (372) | 14.65 (372) | 17.52 (445) | 17.52 (445) |
| D | 10.24 (260) | 10.24 (260) | 12.99 (330) | 12.99 (330) |
| E | 12.99 (330) | 12.99 (330) | 17.00 (432) | 17.00 (432) |
| F | 8.48 (215) | 8.46 (215) | 11.02 (280) | 11.02 (280) |
| G | 1.18 (30) | 1.18 (30) | 1.38 (35) | 1.38 (35) |
| H | — | 1.93 (49) | — | 1.50 (38) |

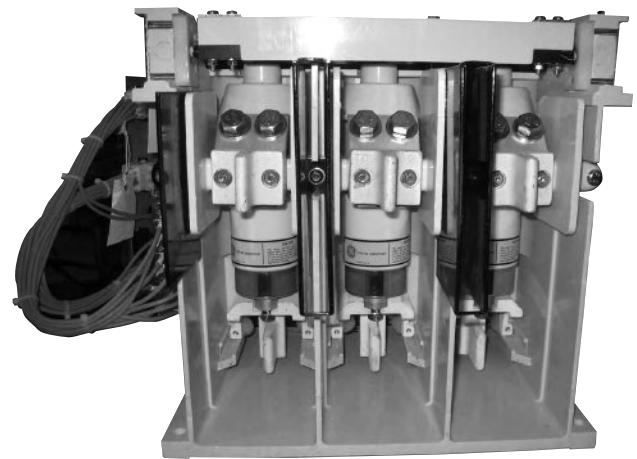

Figure B.3 400-Ampere Vacuum Contactor

Latched Contactors

There are some applications where it is not desirable to disconnect the motor from the line during voltage depression. These applications are generally those associated with a critical drive where the continued rotation of the drive may be more important than possible damage to the motor from low voltage.

The mechanical latch maintains contactor closure under the most severe undervoltage conditions, including complete loss of voltage. Latched contactors may be specified if required by the application. The standard close and trip coils are designed for use on 120 volts rectified AC or 125 volts DC. Trip coils are also available in 24V, 48V and 220V DC. A manual release feature is provided as standard. Capacitor trip devices can also be used for release on the trip coils.

The Limitamp latched contactors are identical to the unlatched versions, with the exception of a small latch attachment mounted on the contactor, which slightly increases the depth of the contactor.

GE Limitamp® Medium Voltage Motor Control Controllers

Latched contactors are interchangeable mechanically with the standard non-latched versions, both from latched to non-latched, and vice versa. However, in each case, it is necessary to change the wiring in the control circuit to the contactor coil or coils and to change the enclosure door to accommodate the manual latch release knob.

Application Notes — Vacuum Contactors

Switching Transients and Vacuum Contactors

Voltage transients when transmitted downstream can be harmful to motor insulation systems. The transients occur in most electrical systems and are usually due to switching surges or lightning strikes. Vacuum contactor switching is only one source of voltage transients. For these reasons GE recommends that customers install surge capacitors and arresters at the motor terminals for vacuum as well as airbreak contactor applications. The surge capacitors reduce the steepness of the voltage transient wavefront, thus reducing the stress on the motor insulation.

Vacuum contactors have proven their suitability as a reliable and safe means of controlling motors, transformers, and capacitor loads. This has been demonstrated by a very good track record over a period of more than 20 years in vacuum Limitamp equipment and much longer in GE Power-Vac switchgear equipment.

Also, an independent Electric Power Research Institute (EPRI) study, investigating the reliability of vacuum switching devices a number of years ago, concluded "... motors switched by vacuum devices had failure rates which are no higher than those for motors switched by air or air-magnetic devices."

Chopping Transients in Vacuum Limitamp

The vacuum switching device is among the best switching device available because it most frequently interrupts load currents in an "ideal" fashion — that is, when the load current is at zero. However, there is a probability that some switching operations may produce voltage transients due to chopping. Chopping is a phenomenon that occasionally occurs as the current through a contactor pole is interrupted during a contactor opening operation.

To understand the nature of chopping, a little understanding of what occurs as a vacuum contactor interrupts current is necessary. When the operating coil of a vacuum contactor is de-energized, kick-out springs in the contactor cause the armature to open and force the vacuum interrupter tips to part. Any current that is flowing through the tips at the instant of parting continues to arc across the open tips. This arcing continues until the sinusoidally varying current approaches

zero. As the polarity reverses across the open tips, current ceases to flow because all charge carriers in the arc disappear during the zero-crossing, leaving in its place a very high dielectric vacuum space. Chopping occurs just before the current zero crossing because the arc becomes unstable under the light current conditions and prematurely interrupts the current. The instantaneous level of current change when this interruption occurs is called the "chop" current. The magnitude of the resulting voltage transients is the product of the "chop current" and the load surge impedance.

GE employs special metallurgy in its tip design to minimize chopping. The tip material consists of a sintered tungsten-carbide material that is impregnated with silver. The tungsten provides long life in hot arcing conditions, and the silver provides for low chop currents. In chop current tests performed on GE's 400 ampere vacuum contactors, it was found that the load surge impedance had significant effect on the average chop current. For example, tests with a surge impedance of 1000 ohms yielded average chop currents of 1.2 amperes but only 0.28 amperes with 4500 ohms surge impedance. These levels of chop currents cause little concern for motor insulation systems.

If motors are expected to be "jogged" or frequently switched-off while accelerating up to speed, surge suppressing devices discussed earlier should be seriously considered to minimize the effects of long term motor winding insulation degradation due to multiple re-ignition transients that can occur while interrupting motor inrush currents. Multiple re-ignitions are surges of arcing current across an opening vacuum interrupter tip that occur in the first few micro-seconds after the tips part. Multiple re-ignitions are virtually non-existent while interrupting normal motor running currents.

Vacuum Interrupter Integrity

The loss of interrupter integrity due to loss of vacuum is a potential concern because the vacuum interrupter ceases to act as an interrupter if vacuum is lost. Vacuum Limitamp interrupters are tested three times during the manufacturing process for vacuum integrity. Historically, this process has reliably eliminated loss of vacuum during normal product operation. To maintain integrity, annual hipot checks are recommended as part of a user's normal preventative maintenance practice. The recommended hipot test voltage is 20 kV AC RMS for the 400 ampere and 800 ampere contactors. The hipot procedures are described in equipment instructions GEH-5305 and GEH-5396.

AC vs. DC Hipot

The AC hipot is recommended for vacuum interrupters because DC hipot may indicate problems with a good interrupter. The reason for this is complex, but in essence there may be microscopic gap broaching "anomalies" across the open

GE Limitamp® Medium Voltage Motor Control Controllers

interrupter tips that the DC hipot cannot distinguish from real problems such as a loss of vacuum. AC hipot systems, on the other hand are able to “burn-off” these anomalies, allowing the good interrupter to recover (Normal contactor load currents will also burn-off these anomalies).

If it is desired to use a DC hipot on a vacuum contactor, it is important to recognize that the results may falsely indicate a bad bottle. Also, DC voltage levels should not be greater than 1.4 times the recommended AC RMS value in order to maintain a safe margin of voltage to X-ray emission. At 35kV small amounts of X-ray radiation may be emitted. The level of emission is well below the allowable levels established in ANSI 37.85-1972. Using DC hipot at 28 kV (1.4 x 20 kV AC RMS) does maintain a safe margin to X-ray emission.

Construction

There are three basic constructions available utilizing the vacuum contactor:

- CR194 two-high 400 Amp
- CR194 one-high 400 Amp
- CR194 one-high 800 Amp

CR194 Two-High 400 Amp

The two-high construction has basic dimensions of 36” wide, 90” high and 30” deep. An optional 40-inch-wide enclosure is also available when additional cabling space is required. Bolted rigid frame construction provides an accurate and simple building platform, giving greater structural strength and flexibility. Full top and bottom compartment isolation is provided for greater safety, and the two-high construction is UL/cUL approved.

A door-in-door construction provides roomy low-voltage compartments, which offer flexibility, safety and high density. A large low-voltage door mounting surface permits multiple relays and metering packages, including drawout relays. The interior of the low-voltage compartment features a white mounting panel, which is easily accessible and provides ample space for numerous control options.



Figure B.4 CR194 two-high construction

The enclosure will accommodate outgoing cable sizes as shown in Table B.6 when both top and bottom compartments house contactors. There is an option to use the top compartment as an incoming line section with limited cable sizes. Refer to the factory for details. Otherwise, an auxiliary section will be required.

It is not necessary to de-energize one controller to service or install the second controller. The enclosure is designed to safely permit termination of one set of motor leads while the other controller is energized.

Main horizontal power bus is available in 1200, 2000 and 3000 amperes. Both the main and vertical bus may be insulated and accessible from front and rear. The horizontal power bus will match with existing Limitamp lineups, including air-break units.

The current ratings are shown in Table B.5.

Table B.5 Ratings and Horsepower Limitations in CR194 Two-high Vacuum Control

| Contactor Location | Maximum Current | | Horsepower | | | | | |
|--------------------|-----------------|------------|------------|------------|------------|------------|------------|------------|
| | | | 2400 Volts | | 4200 Volts | | 7200 Volts | |
| | Vented | Non-Vented | Vented | Non-Vented | Vented | Non-Vented | Vented | Non-Vented |
| Top | 360 | 320 | 1600 | 1200 | 2800 | 2500 | 4500 | 4000 |
| Bottom | 400 | 320 | 1800 | 1200 | 3100 | 2500 | 4500 | 4000 |

GE Limitamp® Medium Voltage Motor Control Controllers

Table B.6 Cable Size Limits (approximate) in CR194 Vacuum Control

| Construction | With Non-shielded Cable | | With Shielded Cable and Prefabricated Stress Cones | | With Shielded Cable and Hand- wrapped Stress Relief | |
|------------------------|-------------------------|-------------|--|---|---|---|
| | Per phase | | Per phase | | Per phase | |
| 400-Ampere | Incoming | Load | Incoming | Load | Incoming | Load |
| One-high 26"-wide Case | 1-500 kcmil | 1-500 kcmil | 1-500 kcmil | 1-500 kcmil | 1-500 kcmil | 1-250 kcmil preferred 1-500 kcmil possible |
| One-high 34"-wide Case | 2-500 kcmil | 2-500 kcmil | 2-500 kcmil | 2-500 kcmil | 2-500 kcmil | 2-500 kcmil |
| One-high 36"-wide Case | 2-500 kcmil | 2-500 kcmil | 2-500 kcmil | 2-500 kcmil | 2-500 kcmil | 2-500 kcmil |
| Two-high 36"-wide Case | Contact Factory | 1-500 kcmil | Contact Factory | 1-250 kcmil preferred 1-500 kcmil possible | Contact Factory | 1-#3/0 preferred 1-#4/0 possible |
| Two-high 40"-wide Case | Contact Factory | 1-500 kcmil | Contact Factory | 1-500 kcmil | Contact Factory | 1-250 kcmil |
| 800-Ampere | | | | | | |
| One-high 48"-wide Case | 2-750 kcmil | 2-750 kcmil | 2-750 kcmil | 2-750 kcmil | 2-750 kcmil | 2-750 kcmil |

CR194 One-High 400 Amp

The one-high packaging (one contactor per enclosure) for the 400-ampere vacuum contactor has basic dimensions of 26 inches wide, 90 inches high, and 30 inches deep, including power bus. It is constructed from a welded enclosure to house a single vacuum contactor in the high-voltage compartment located at floor level. The entire upper compartment is available for low-voltage equipment and includes a swing-out panel for ease of component mounting and accessibility.

This enclosure will accommodate cable sizes as shown in Table B.7. Cable runs may enter from top or bottom without modification. Top or bottom cable entrance into the enclosure does not need to be specified.

The one-high design will accommodate the following combination of components:

1. One three-phase potential transformer used for metering.
2. Up to 10 kVA extra capacity CPT (34" wide only). 3 KVA max on two-high design.
3. Up to approximately 10 control relays for induction motor starters.
4. Two size S1 drawout relay cases.

A 34-inch-wide, one-high enclosure is available as an option, where more cable room or multiple cable connections are required. Power factor correction capacitors can also be supplied and will be mounted in an auxiliary enclosure. A 36-inch-wide, one-high enclosure is also available as an option where a drawout contactor is required. See Table B.7 for maximum cable sizes.

CR194 One-High 800-Amp

The one-high enclosure for the 800-ampere vacuum contactor has basic dimensions of 48" wide, 90" high and 30" deep in a welded frame. Maximum cable sizes are shown in Table B.5. Protected raceways isolate the motor and power leads from one another. Cable runs may enter from the top or bottom and are straight runs.

Weights and Dimensions

Vacuum Limitamp control varies in weight by controller type and construction. The approximate weight for estimating purposes is included in Table B.9.

Overall size of controllers vary according to type of controller as shown in Table B.9.

Main horizontal power bus for electrically connecting sections of Limitamp control does not add to the standard 90-inch height.

GE Limitamp® Medium Voltage Motor Control Controllers

Table B.7 Estimated Weights and Dimensions — CR194 Vacuum Controllers, NEMA 1 Vented Enclosure ①

| Controller Type ^② One High (One Starter) ^⑤ | Contactor Ampere Rating ^③ | 2400 Volts | | | 4000-4800 Volts ^④ | | | 7200 Volts | | | | | |
|--|--|----------------------------|------------------------------|--|------------------------------|------------------------------|--|----------------------------|------------------------------|--|-----------|------|----|
| | | Max HP 3-Phase 50/60 | Approx. weight in lbs. | Width in inches ^⑥ (90 high x 30 deep) | Max HP 3-Phase 50/60 | Approx. weight in lbs. | Width in inches ^⑥ (90 high x 30 deep) | Max HP 3-Phase 50/60 | Approx. weight in lbs. | Width in inches ^⑥ (90 high x 30 deep) | | | |
| Squirrel-Cage Induction | | | | | | | | | | | | | |
| Full-Voltage Nonreversing | 400 | 1600 | 1200 | 26 | 2800 | 1200 | 26 | 4800 | 1200 | 34 | | | |
| | 800 | 3200 | 1400 | 48 | 5600 | 1450 | 48 | — | — | — | | | |
| Full-Voltage Reversing | 400 | 1600 | 1500 | 58 | 2800 | 1500 | 58 | | | | | | |
| Reduced-Voltage Nonreversing | | | | | | | | | | | | | |
| Primary Reactor Type | 400 | 1000 | 2800 | 58 | 1000 | 2800 | 58 | | | | | | |
| | 400 | 1600 | 4800 | 98 | 2800 | 4800 | 98 | | | | | | |
| Autotransformer Type (Closed Transition) | 400 | 1000 | 3000 | 58 | 1000 | 3000 | 58 | | | | | | |
| | 400 | 1600 | 5000 | 66 | 2800 | 5000 | 98 | | | | | | |
| | 800 | 3200 | 5200 | 112 | 5600 | 5200 | 112 | | | | | | |
| Two-Step Part-Winding Nonreversing | 400 | 1600 | 1400 | 58 | 2800 | 1400 | 58 | | | | | | |
| Two-Speed One- Winding FVNR | 400 | 1600 | 1600 | 68 | 2800 | 1600 | 68 | | | | | | |
| Two-Speed Two- Winding FVNR | 400 | 1600 | 1400 | 58 | 2800 | 1600 | 58 | | | | | | |
| Synchronous Induction FVNR | 400 | 0.8 PF | 1.0 PF | 1400 | 34 | 0.8 PF | 1.0 PF | 1400 | 34 | 0.8 PF | 1.0 PF | 1400 | 34 |
| | | 1600 | 2000 | | | 2500 | 3500 | | | 4800 | 5500 | | |
| Brush Type & Brushless | 800 | 3200 | 4000 | 2600 | 48 | 5600 | 7000 | 2600 | 48 | — | — | — | — |
| Synchronous Motor, RVNR | | | | | | | | | | | | | |
| Primary Reactor | 400 | 1000 | 3000 | 68 | 1000 | 3000 | 68 | | | | | | |
| | 400 | 1600 | 5000 | 90 | 2800 | 5000 | 90 | | | | | | |
| Autotransformer | 400 | 0.8 PF | 1.0 PF | 3200 | 76 | 0.8 PF | 1.0 PF | 3200 | 76 | | | | |
| | | 1000 | 1250 | | | 1000 | 1250 | | | | | | |
| | | 1600 | 2000 | | | 2800 | 3500 | | | | | | |
| Induction/Synchronous Motor, RVNR Neutral Reactor | 400 | | | | | | | | | 0.8 PF | 1.0 PF | | 68 |
| | | | | | | | | | | 4800 | 5500 | | |

① See Enclosure & Bus Ratings Section E for NEMA 3R enclosures.

② For wound-rotor motor starter consult factory.

③ Derate by 0.8 for non-vented enclosures.

④ Maximum horsepower at 4160 volts AC in one-high NEMA 1 enclosure.

⑤ Two-high Starters are available in bolted-frame construction, available only for 400 ampere, squirrel-cage FVNR applications.

Dimensions are 36" wide x 90" high x 30" deep. Weight is 2000 lbs.

⑥ Dimensions shown are approximate, based on standard motor designs.

B

GE Limitamp® Medium Voltage Motor Control 5kV Load-break Switches

Introduction

IC1074 load-break switches are manually operated three-phase, single-throw disconnecting switches with an integral interrupter and stored-energy spring that has the capability of interrupting magnetizing and load current within the ratings shown in Table C.1. They are designed and tested to comply with the performance requirements of ANSI C37.57 and C37.58.

The IC1074 600-ampere drawout switch is designed for stab connection at line and load terminals. This switch must be fused. Current-limiting fuses are available up to a continuous rating of 630 amperes for installation in the switch.



Figure C.1 1200-ampere stationary load-break switch

The switch is designed to accommodate the bolt-on version of the current-limiting fuse, but clip mounting is available. Construction may be either one- or two-high, with one-high in a rollout design instead of drawout. Either two switches or a combination switch and 5kV air-break starter can be mounted in a two-high enclosure.

The IC1074 stationary switch (600- or 1200-ampere) is designed for mounting in one-high construction only. It contains line- and load-terminal pads for bolting incoming and outgoing conductors directly to the switch. It may be supplied fused or unfused. If supplied as an unfused switch, an upstream circuit breaker with instantaneous trips must be available to coordinate with switch capabilities — or the switch must be supplied with key lock capabilities — for all of the Limitamp starters in the lineup. For the 1200-ampere

switch, fuses are available up to 960 amperes continuous. These large fuses must be applied as line protectors for short circuit only, relying upon branch circuits or backup overload protection by other means.

Drawout switches must be applied as feeders only. The fixed mounted switches may be used as incoming switches or feeder switches.

These switches are designed specifically for use with Limitamp control. They are available with 1000- or 2000-ampere AC main power bus within the enclosure for easy lineup with Limitamp starters. 3000-ampere is available with extra depth.

Other features of these switches are:

- Viewing window to see condition and position of switch blades.
- Blown-fuse indicator that can be seen through view window.
- Bolted fuses available for maximum reliability.
- High reliability interruption.
- Available with key-type interlocks. Maximum of three keys per position (lock open or lock closed).
- Outside door interlocked directly to operating shaft to prevent opening with switch energized.
- Externally operated handle that activates spring-charged quick-make/quick-break mechanism.
- Easy inspection.
- High mechanical life.
- UL available in stationary switches only.

GE Limitamp® Medium Voltage Motor Control 5kV Load-break Switches

Table C.1 IC1074 Load-break Switch Technical Specifications

| Type | 600-Ampere Drawout Switch (Fuse) | 600-Ampere Stationary Switch (Fused or Unfused) | 1200-Ampere Stationary Switch (Fused or Unfused) |
|---|---|--|--|
| Ratings | | | |
| Maximum nominal rating | 4760 volts | 4760 volts | 4760 volts |
| Unfused rating Vented enclosure Non-vented enclosure | N/A N/A | 600 amperes 540 amperes | 1200 amperes 1020 amperes |
| Fused rating Vented enclosure Non-vented enclosure | 600 amperes 540 amperes | 600 amperes 540 amperes | 960 amperes 840 amperes |
| Make/Break rating | 600 amperes | 600 amperes | 1200 amperes |
| Fault-closing rating (asym) Fused Unfused | 61,000 amperes N/A | 61,000 amperes 61,000 amperes | 61,000 amperes 61,000 amperes |
| Momentary rating (asym) Unfused | N/A | 61,000 amperes | 61,000 amperes |
| Basic impulse level (BIL) | 60 kV | 60 kV | 60 kV |
| Short-circuit interrupting capacity (fused) 2400 volts 4800 volts | 200 MVA (sym) 400 MVA (sym) | 200 MVA (sym) 400 MVA (sym) | 200 MVA (sym) 400 MVA (sym) |
| Dimensions | | | |
| | Dimensions in inches (W x H x D) | Dimensions in inches (W x H x D) | Dimensions in inches (W x H x D) |
| One-high construction | 34 x 90 x 30 | 38 x 90 x 30 | 38 x 90 x 30 |
| One-high construction (option) | 42 x 90 x 30 | N/A | N/A |
| Two-high construction | 44 x 90 x 30 | N/A | N/A |
| Cable space | | | |
| Incoming 38"-wide case | N/A | 2-500 kcmil per phase with or without stress cones | 2-500 kcmil per phase with or without stress cones |
| Outgoing 38"-wide case | N/A | 2-500 kcmil per phase with or without stress cones | 2-500 kcmil per phase with or without stress cones |
| Incoming (for bus only) 34"-wide case | 2-500 kcmil per phase without stress cones 1-500 kcmil per phase with stress cones | N/A | N/A |
| 42"-wide case | 2-750 kcmil per phase with or without stress cones | N/A | N/A |
| 44"-wide case | 1-500 kcmil per phase with or without stress cones | N/A | N/A |
| Outgoing 34"-wide case 42"-wide case 44"-wide case | 1-500 kcmil per phase with stress cones 2-750 kcmil per phase with or without stress cones 1-300 kcmil per phase with or without stress cones | N/A N/A N/A | N/A N/A N/A |

GE Limitamp® Medium Voltage Motor Control

Incoming Line

Cable-entrance Compartment

When incoming cable exceeds limits shown in the cable size limits tables, an optional cable-entrance compartment is required.

Transition Compartment

Limitamp control can be close-coupled to transformers and switchgear by a transition compartment to make a continuous lineup. The transition compartment is normally 22 inches wide; however, this can vary. See Table D.1.

Bus Entrance Compartment

Bus entrance compartments are required in all cases where power is fed to the controller lineup by means of bus. See Table D.1.

Cable Terminals

Terminal lugs for both line and load cables are not supplied unless specified.

Mechanical compression lugs or NEMA 2-hole compression-type lugs can be supplied as options.

The customer must specify the number and size cable when lugs are to be supplied by GE.

Where aluminum cable is to be used, special attention must be given to terminal selection.

High-Resistance Grounding Equipment

High-resistance grounding equipment can be mounted in an enclosure which will match and line up with Limitamp dimensions and bus location.



Table D.1 General Guidelines for Incoming Lines

| Incoming Line | Maximum Cable Size per Phase | Enclosure Width | Typical Device Devices That Can Be Included |
|------------------------------------|---|---------------------------------|---|
| Cable Compartment Top Entry | 4-500 kcmil | 22" | VM, VMS, 2 stationary PTs, lightning arresters and surge capacitors |
| | 4-750 kcmil | 32" | All of the above plus 3 CTs, AM and AMS |
| | 4-750 kcmil | 38" | All of the above plus D/O PTs can replace the stationary PTs. 1 D/O CPT can be mounted. |
| Cable Compartment Bottom Entry | Same as top entry except a D/O CPT cannot be mounted in the enclosure | | |
| Bus Entrance Compartment | N/A | 32" | Same as 32"-wide cable compartment |
| Transition to GE Switchgear | N/A | 22" | VM, VMS, 2 stationary PTs, lightning arresters and surge capacitors |
| Transition to GE Transformer | N/A | 22" | Accessories cannot be mounted in transformer transition. Additional auxiliary enclosure is required. |
| Load-break Switch Fused or Unfused | 2-500 kcmil top or bottom | 38" | AM, AMS, 3 CTs, 2 stationary PTs, VM and VMS |
| | | 38" and 22" auxiliary enclosure | Same as 38" switch plus lightning arresters, surge capacitors and switchgear relay can be mounted in the 22" wide enclosure |
| | | 38" and 38" auxiliary enclosure | Same as 38" switch except D/O PTs can be mounted in the auxiliary enclosure plus switchgear relays |

GE Limitamp® Medium Voltage Motor Control Enclosures

Enclosures

NEMA Type 1 — General Purpose

The NEMA Type 1 is the standard Limitamp enclosure designed primarily to prevent accidental contact with control apparatus. This enclosure is suitable for general purpose indoor applications with normal atmospheres. For CR194 two-high design with vented enclosures, add 2 1/2" to the height.

NEMA Type 1A — Gasketed

The NEMA Type 1A rubber-gasketed enclosure is a dust-resistant enclosure (not dust-tight), designed to give protection against dust, and when control devices are properly selected, to give proper operation in a dusty atmosphere. It is recommended for all moderately dusty atmospheres, especially in those industries whose dusts are abrasive, conductive, or form high-resistance contacts. NEMA Type 1A rubber-gasketed enclosures are not provided with steel bottoms. It is expected that the case will sit on concrete, effectively sealing the bottom against dust.

NEMA Type 2 — Driptight

This enclosure is made to protect control apparatus against falling moisture or dirt. All openings are rubber-gasketed and provided with doors or covers. It is intended for use in atmospheres where condensation is heavy or where quantities of water are used in a process or for cleaning. (For applications where a hose is to be directed on the equipment from any direction except above, use NEMA Type 4.) Normal instruments, meters and devices are mounted on the door as in NEMA Type 1. Strip heaters are used only as the application requires them.

NEMA Type 3R — Weather-Resistant

These enclosures must be suitable for outdoor installation and offer protection against driving rain and snow storms, as well as against dust. Limitamp NEMA 3R enclosures are provided with solid-steel bottoms and tops, an overhanging sloping roof and strip heaters, with provisions for future extension.

The following types of NEMA 3R enclosures are available:

- NEMA Type 3R, weather-resistant, full-height cover door, non-walk-in (42 inches deep by 101 inches high). (Use when a number of devices are on the door.)
- NEMA Type 3R, weather-resistant walk-in (92 inches deep by 111 1/4 inches high).

Walk-in enclosures allow ample space for inspection and maintenance of starters within the enclosure.

Standard construction is suitable for wind velocities of 130 mph and roof loading up to 30 pounds per square foot. Exterior finish is applied by an electro-static powder coat process (polyester based).

NEMA Type 12 — Dusttight

These cases are designed to meet the requirements of industrial locations where protection is required against entrance of fibers and flying lint, dust, dirt, light splashing, seepage dripping and external condensation of non-corrosive liquids.

Typical requirements for NEMA 12 are:

- A gasketed cover that is hinged to swing horizontally, and held in place with screws, bolts or other suitable fasteners.
- No open holes through the enclosure. All openings are sealed with gasketed cover plates.
- No conduit knockouts or knockout openings.
- Steel bottom.

Indoor Enclosure Construction

Limitamp indoor enclosures are manufactured from 12-gauge steel throughout, except for 13-gauge on the rear covers. For surface preparation, see the Application Data section.

Choice Of Mounting — Indoor

You may select either back-to-back (60 inches deep) or back-to-wall (30-inches deep) mounting, letting you arrange control lineups to your own floor space and application requirements. rewrite to accommodate 3000A



Back-to-back mounting

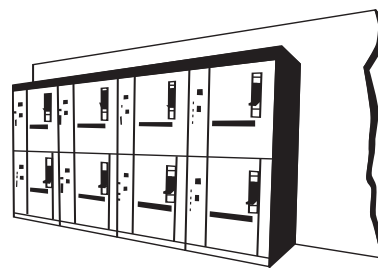

Back-to-wall mounting

GE Limitamp® Medium Voltage Motor Control Enclosures

Table E.1 Enclosure dimensions

| Type | Description | Page |
|--|---|------|
| NEMA 1 motor starters bolted construction | CR194 400A, 2 high, 36" wide (stationary or draw-out) | E4 |
| | CR194 400A, 2 high, 40" wide (stationary or draw-out) | E5 |
| | CR194 400A, 1 high, 36" wide (stationary or draw-out) | E6 |
| | CR194 400A, 1 high, 40" wide (stationary or draw-out) | E7 |
| NEMA 1 motor starters welded construction | CR194 400A, 1 high, 26" wide | E8 |
| | CR194 400A, 1 high, 34" wide | E9 |
| | CR194 800A, 1 high, 48" wide | E10 |
| NEMA 3R motor starters bolted construction | CR194 400A, 1 high, 36" wide non-walk-in (stationary or draw-out) | E11 |
| | CR194 400A, 1 high, 40" wide non-walk-in (stationary or draw-out) | E12 |
| | CR194 400A, 1 high, 36" wide walk-in (stationary or draw-out) | E13 |
| | CR194 400A, 1 high, 40" wide walk-in (stationary or draw-out) | E14 |
| NEMA 3R motor starters welded construction | CR194 400A, 1 high, 34" wide & CR194 800A, 1 high, 48" wide non-walk-in | E15 |
| | CR194 400A, 1 high, 26" & 34" wide walk-in | E16 |
| | CR194 800A, 1 high, 48" wide walk-in (stationary or draw-out) | E17 |
| NEMA 1 IC1074 bolted load break switch | 1200A & 600A, 1 high, 38" wide | E18 |
| NEMA 3R IC1074 draw-out load break switch | 600A, 2 high, 44" wide non-walk-in | E19 |
| | 600A, 2 high, 44" wide walk-in | E20 |

Nameplates

Enclosure nameplates are provided for identification on front panels and internally for identifying units and devices.

Standard unit nameplates are 1" x 3" 2-ply thermoplastic, black letters on white background or white letters on black background.

Front panel device nameplates are 1/2" x 1 1/2" thermoplastic.

Internal device nameplates are fabric type with adhesive backing. Update. Optional Thermoplastic nameplates are available as an option

Thermoplastic nameplates are available with optional corrosion-resistant steel screws.

Table E.2 Enclosure features

| Description | NEMA 3R Non-walk-in | NEMA 3R Walk-in |
|--------------------|-----------------------|-----------------------|
| | 42" deep | 92" deep |
| Strip heater | Standard ¹ | Standard ² |
| Thermostat | Standard | Standard |
| Receptacle | Option | Standard |
| Incandescent light | Option | Standard |
| Door stops | Standard | Option |
| Floor sills | Standard | Standard |

¹ In starter only

² One in starter, one in aisle

Limitamp Bus Systems

AC power bus is used for conducting power throughout a group of starters joined together in a lineup. Incoming power

can be terminated at one or more points in the lineup and the power bus employed to distribute power throughout the length of the group.

This bus is available in ratings of 1200, 2000 and 3000 (foot-note) amperes and may be tin-plated copper, silver-plated copper or bare copper. NEMA 1 is available up to 3600A. For higher ratings refer to factory. Derating is necessary in certain applications. The 1200/2000A horizontal bus compartment is located within the standard 90-inch-high enclosure in the same position as in current and previous air-break designs, dating back to 1960, making all compatible. Limitamp horizontal bus is rated 60kV basic impulse level (1.2 x 50? sec wave). Mechanical strength under short-circuit currents is 50 kA RMS symmetrical.

Ground Bus

Ground bus in a Limitamp lineup provides a low-resistance path between ground connection points in any group of controllers. This low-resistance path is a bus bar and is for the purpose of decreasing to a low value a possibly hazardous voltage difference between grounding points in the starter group. These voltage differences would occur under ground fault conditions if a low-resistance ground path were not provided.

The ground bus is normally located near the AC power bus on the inside rear of the enclosure. The bus provides a common termination point for all ground connections within each controller, including the enclosing case, and offers a convenient terminal for incoming ground cables. It should be noted that the customer must make a suitable ground connection to the bus in order to make it effective. When ground bus is not provided, the ground connection may be made to the ground stud provided.

Extensions to the ground bus are located in the incoming line cable compartment and near the load termination points in the high-voltage compartment to make grounding cable shield terminations easy to accomplish.

Control Bus

Control (wired) bus is a convenient means of conducting control power throughout a group of controllers joined together in a lineup. Conductors from a single control power source may be terminated in one unit in the lineup and the control bus employed to distribute the power to each unit of the grouped lineup. Control bus may also be used to distribute the power from a single control transformer located in the lineup.

Control bus normally consists of properly sized insulated wire conductors run between terminal boards.

Standard voltage for control bus is 120 or 240 volts AC and

GE Limitamp® Medium Voltage Motor Control Enclosures

maximum current rating is determined by application, such as total present and anticipated future load.

Potential Bus

Potential (wired) bus is a means of distributing a common source of low voltage throughout the lineup for metering and instrumentation. Potential bus consists of properly sized wire connected between terminal boards typically mounted on the top inside of enclosure. Maximum voltage is 600 volts.

Communication Bus

Communication (wired) bus is a means —finish edit.

Insulated Power Bus

Insulating the AC power bus reduces the possibility of bus faults from causes such as surge voltages, ionized vapors, falling objects (tools, etc.), ground tapes, etc. It also prevents corrosion and oxidation of the bus and its hardware.

The standard power bus consists of bare conductors on insulator supports. Insulation for the conductors can be provided, and it may consist of various types of insulating material, such as 130°C HV rubber splicing tape or other material dictated by availability and individual job requirements.

The CR194 two-high Vacuum Equipment design uses epoxy-insulated 2000A max main and vertical bus as standard.

Table E.3 Bus cross section

| Bus type | Rating | Cross section |
|--------------|--------|----------------------|
| Main bus | 1200A | 1/4" x 3" copper |
| | 2000A | (2) 1/4" x 3" copper |
| | 3000A | (2) 1/26?? |
| Vertical bus | 400A | 1/4" x 1" copper |
| | 800A | 1/4" x 3" copper |
| Ground bus | 400A | 1/8" x 2" copper |
| | 600A | 1/4" x 2" copper |

GE Limitamp® Medium Voltage Motor Control Enclosures

Enclosure Outline Dimensions 2400-4160 Volts CR194 400A, 2 high, 36" wide (stationary or draw-out)

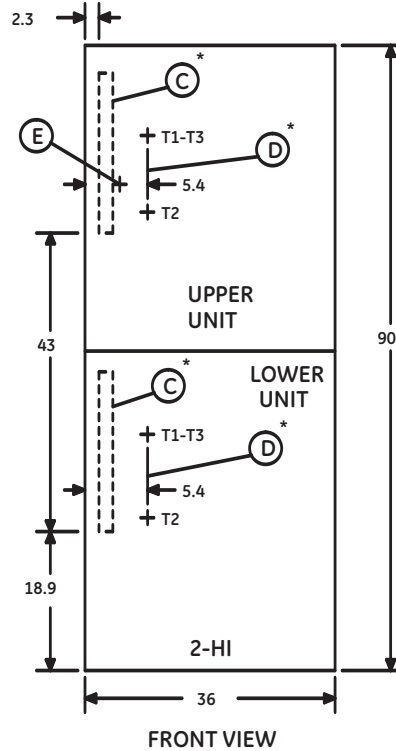
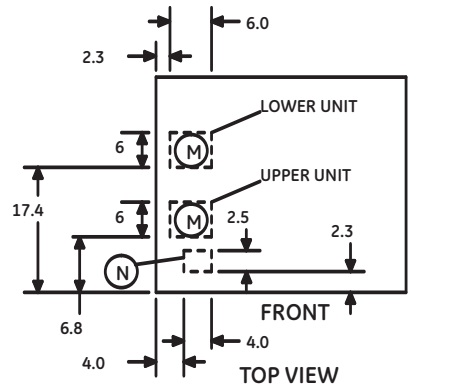
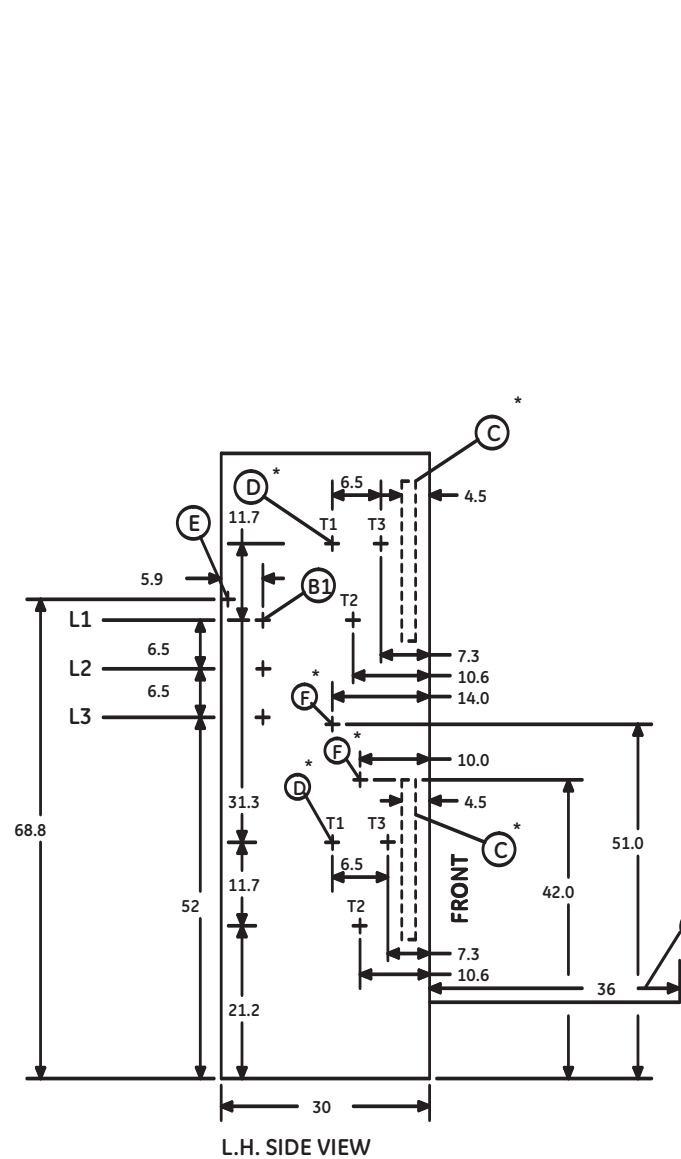

▲ - 2000 lbs.
909 kg.

Notes:

- B1 — AC Power Bus
- C — Control Lead Terminal Board
- D — Motor Lead Terminal Connection
- E — Ground Bus Terminal Connection
- G — Space Required to Open Doors 90°
- H — Four-foot Aisle for Contactor Removal
- J — Mounting Holes for 1/2" Diameter Anchor Bolts
- M — Recommended Position for Incoming Motor Conduit
- N — Recommended Position for Incoming Control Conduit
- * — Indicates Terminal Location - Approximate for Cable Length
- ▲ — Approximate Weight

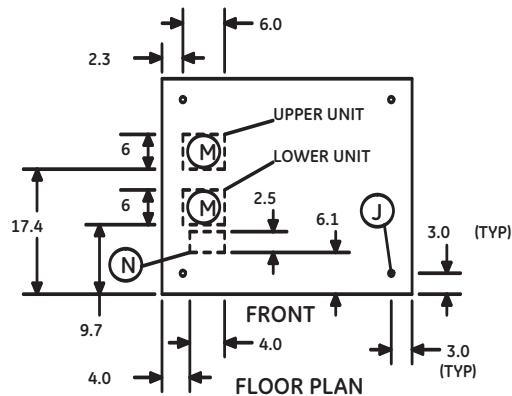

GE Limitamp® Medium Voltage Motor Control Enclosures

Enclosure Outline Dimensions 2400-4160 Volts CR194 400A, 2 high, 40" wide (stationary or draw-out)

E

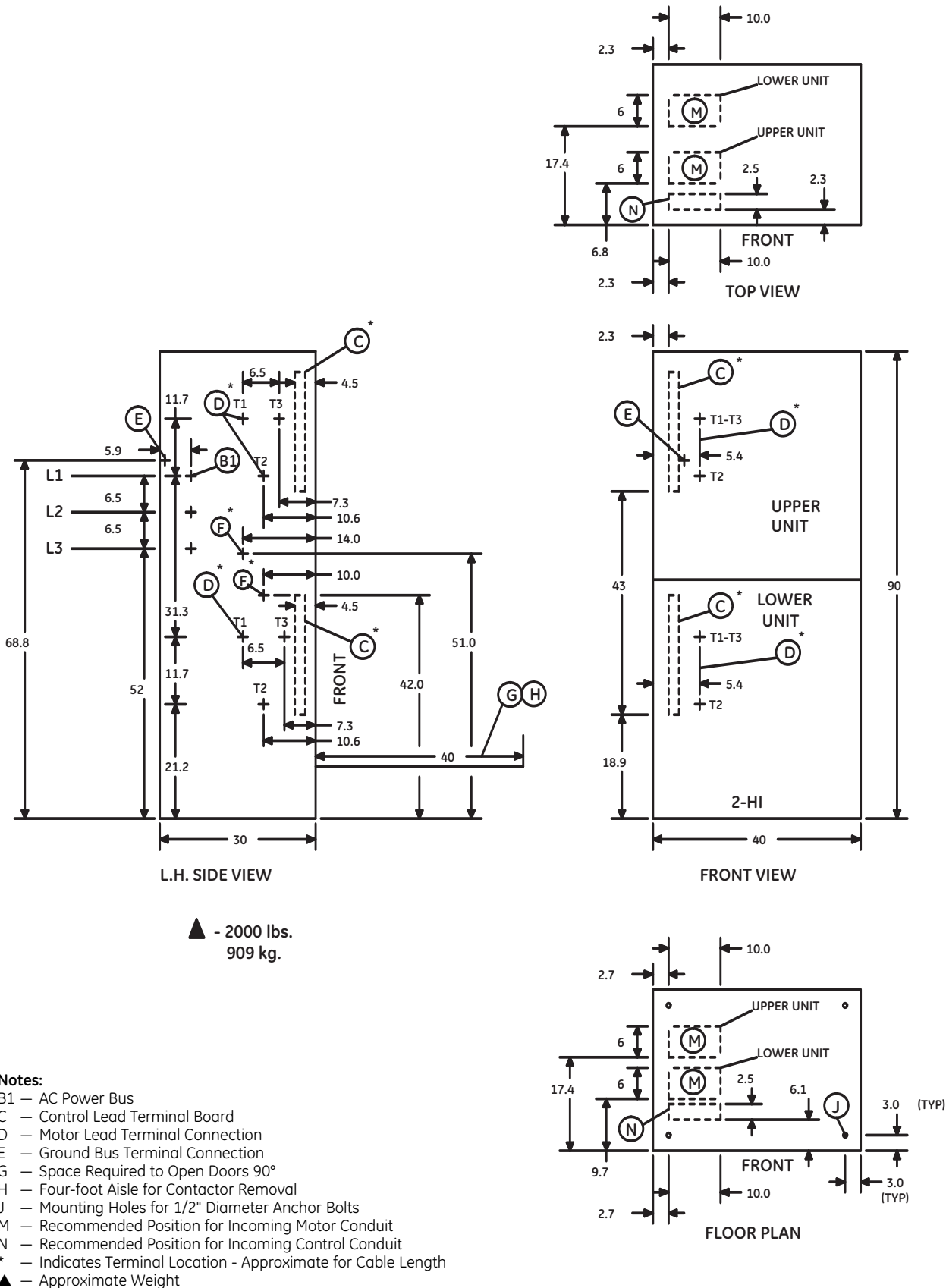

GE Limitamp® Medium Voltage Motor Control Enclosures

Enclosure Outline Dimensions 2400-4160 Volts CR194 400A, 1 high, 36" wide (stationary or draw-out)

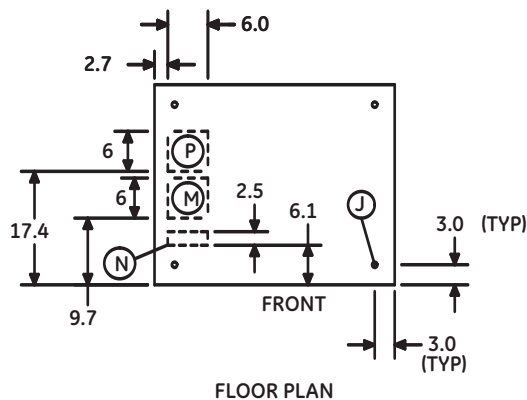
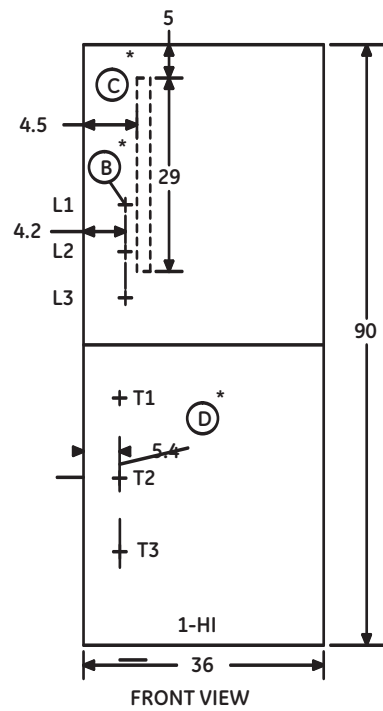
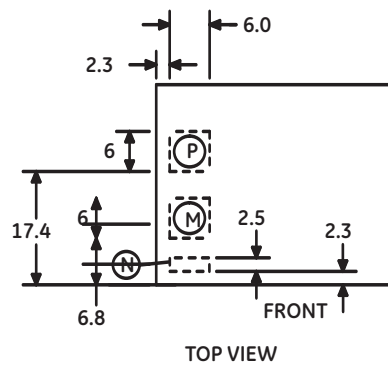
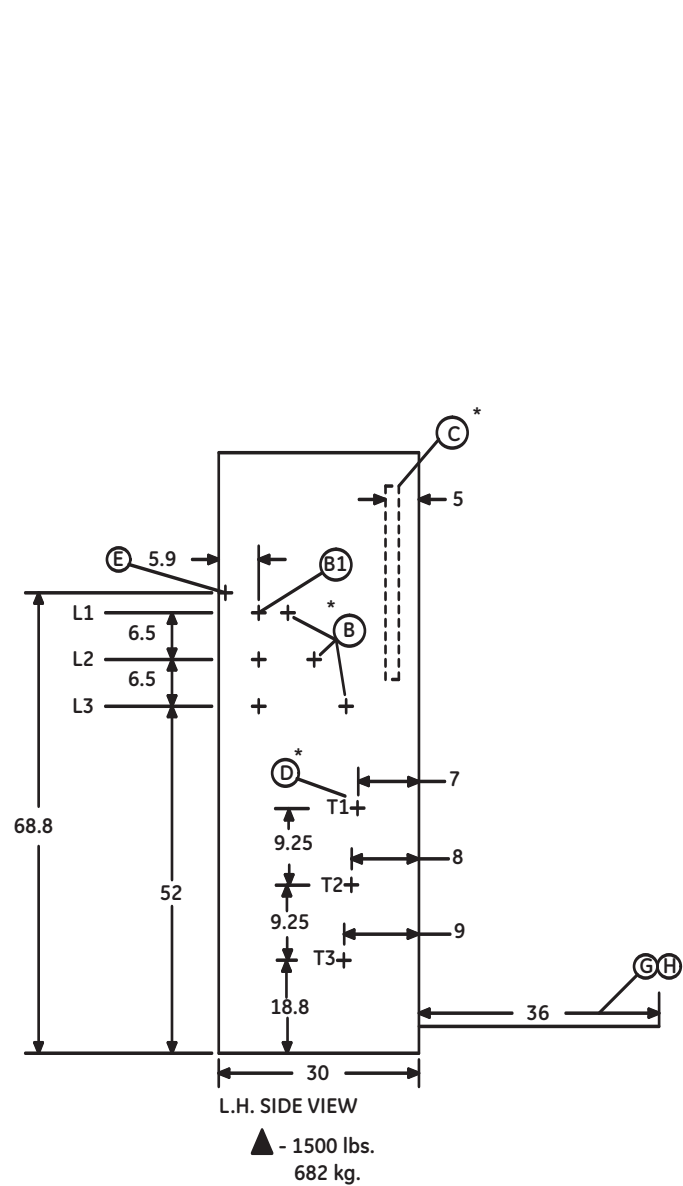

Notes:

- B — Incoming Power Terminal Connection
- B1 — AC Power Bus
- C — Control Lead Terminal Board
- D — Motor Lead Terminal Connection
- E — Ground Bus Terminal Connection
- F — Ground Terminal Connection (If Ordered)
- G — Space Required to Open Doors 90°
- H — Aisle for Contactor Removal
- J — Mounting Holes for 1/2" Diameter Anchor Bolts
- K — Space Available for Incoming Conduit
- M — Recommended Position for Incoming Motor Conduit
- N — Recommended Position for Incoming Control Conduit
- P — Recommended Position for Incoming Power Conduit
- * — Indicates Terminal Location - Approximate for Cable Length
- ▲ — Approximate Weight

GE Limitamp® Medium Voltage Motor Control Enclosures

Enclosure Outline Dimensions 2400-4160 Volts CR194 400A, 1 high, 40" wide (stationary or draw-out)

E

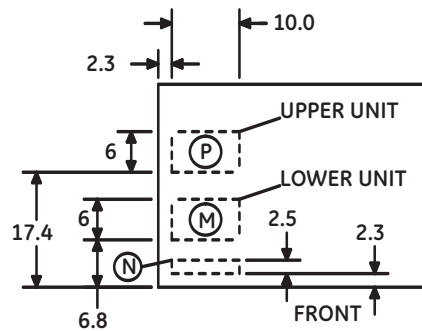

TOP VIEW

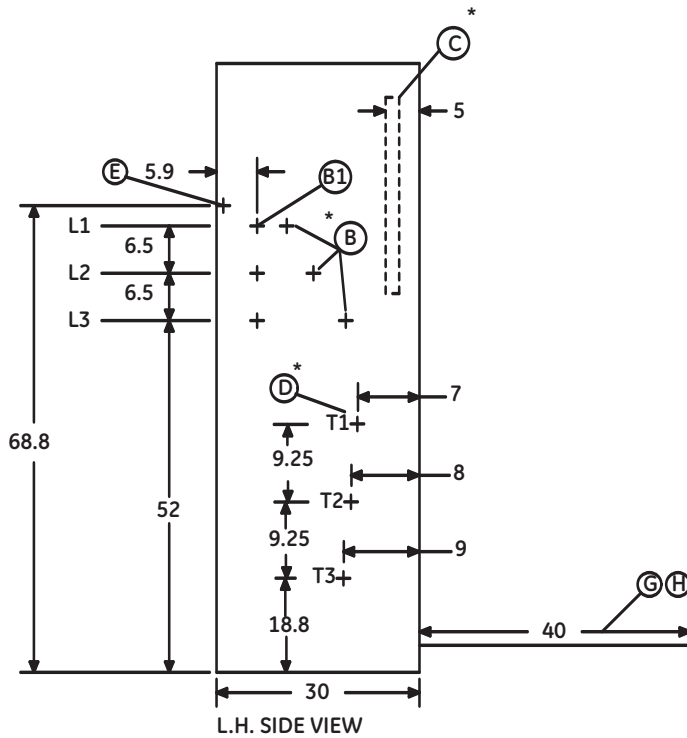

L.H. SIDE VIEW

▲ - 1800 lbs.
818 kg.

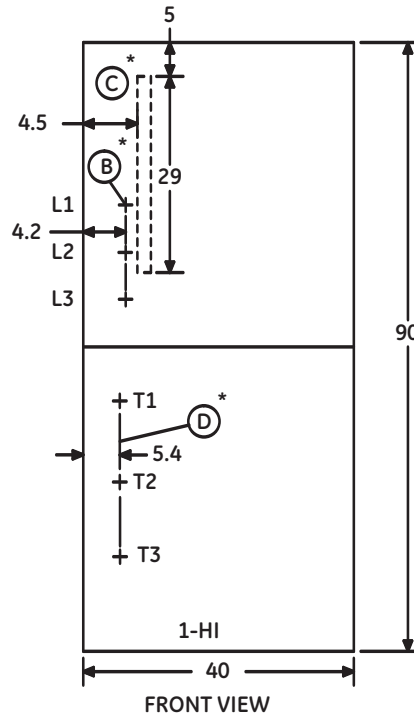

FRONT VIEW

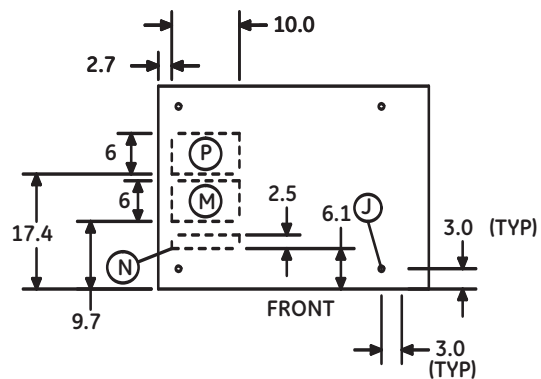

FLOOR PLAN

Notes:

- B — Incoming Power Terminal Connection
- B1 — AC Power Bus
- C — Control Lead Terminal Board
- D — Motor Lead Terminal Connection
- E — Ground Bus Terminal Connection
- F — Ground Terminal Connection (If Ordered)
- G — Space Required to Open Doors 90°
- H — Aisle for Contactor Removal
- J — Mounting Holes for 1/2" Diameter Anchor Bolts
- K — Space Available for Incoming Conduit
- M — Recommended Position for Incoming Motor Conduit
- N — Recommended Position for Incoming Control Conduit
- P — Recommended Position for Incoming Power Conduit
- * — Indicates Terminal Location - Approximate for Cable Length
- ▲ — Approximate Weight

GE Limitamp® Medium Voltage Motor Control Enclosures

Enclosure Outline Dimensions 2400-4160 Volts CR194 400A, 1 high, 26" wide

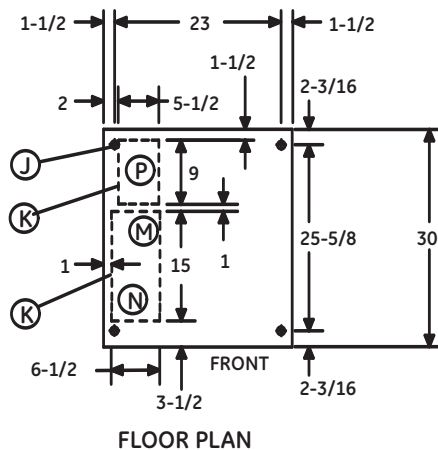
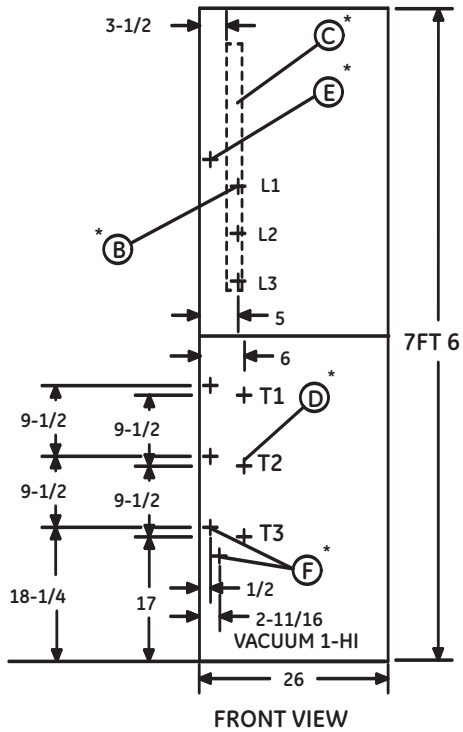
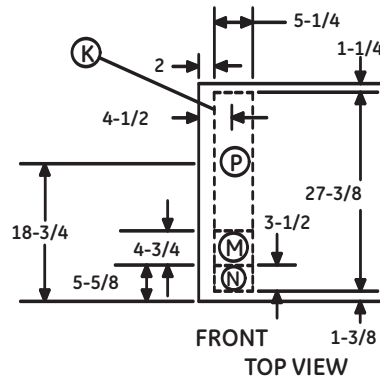
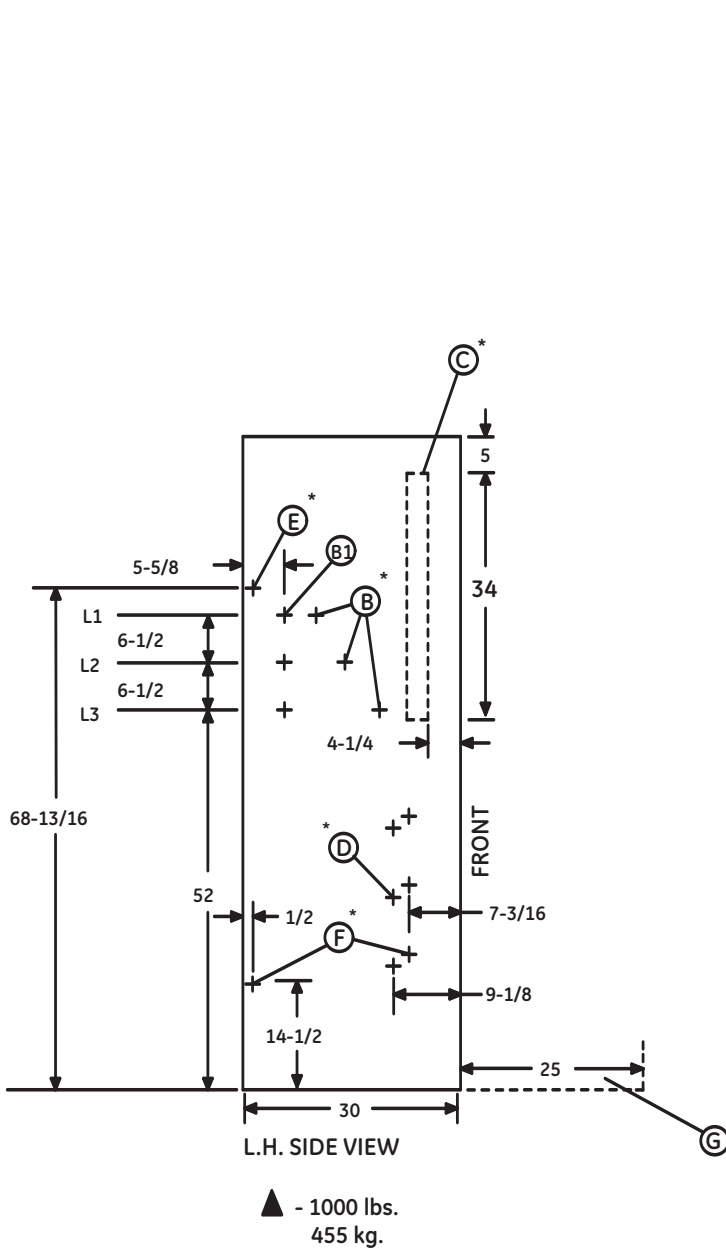

Notes:

- B1 — AC Power Bus (if ordered)
- C — Control Lead Terminal Board
- D — Motor Lead Terminal Connection
- E — Ground Bus Terminal Connection
- F — Ground Terminal Connection (if ordered)
- G — Space Required to Open Doors 90°
- H — Four-foot Aisle for Contactor Removal
- J — Mounting Holes for 1/2" Diameter Anchor Bolts
- K — Space Available for Incoming Conduit
- M — Recommended Position for Incoming Motor Conduit
- N — Recommended Position for Incoming Control Conduit
- P — Recommended Position for Incoming Power Conduit
- * — Indicates Terminal Location - Approximate for Cable Length
- ▲ — Approximate Weight

GE Limitamp® Medium Voltage Motor Control Enclosures

Enclosure Outline Dimensions 2400-4160 Volts CR194 400A, 1 high, 34" wide

E

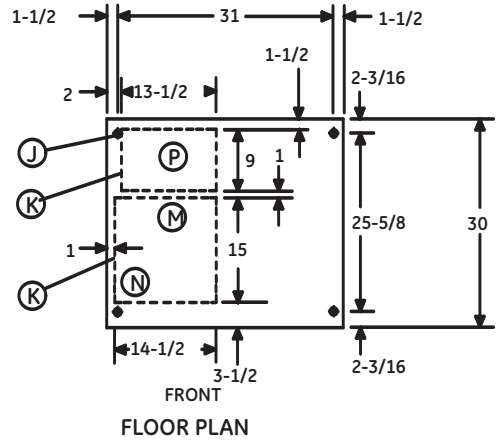
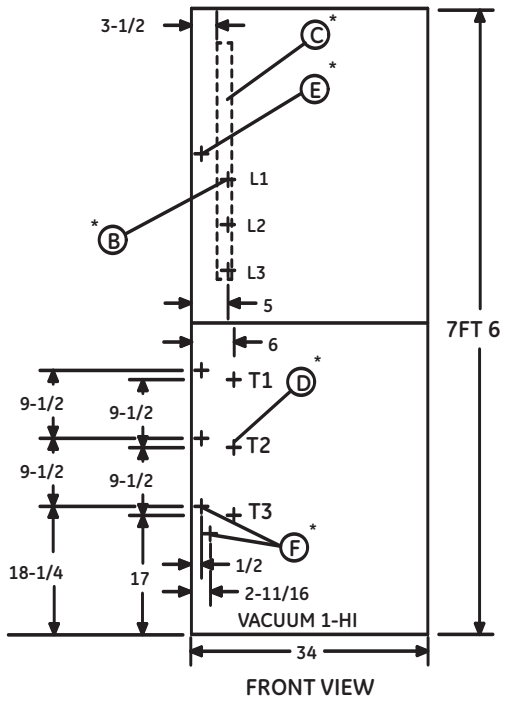
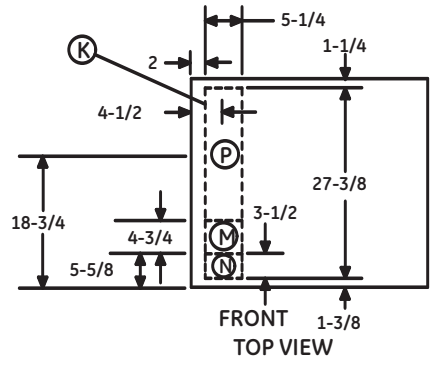
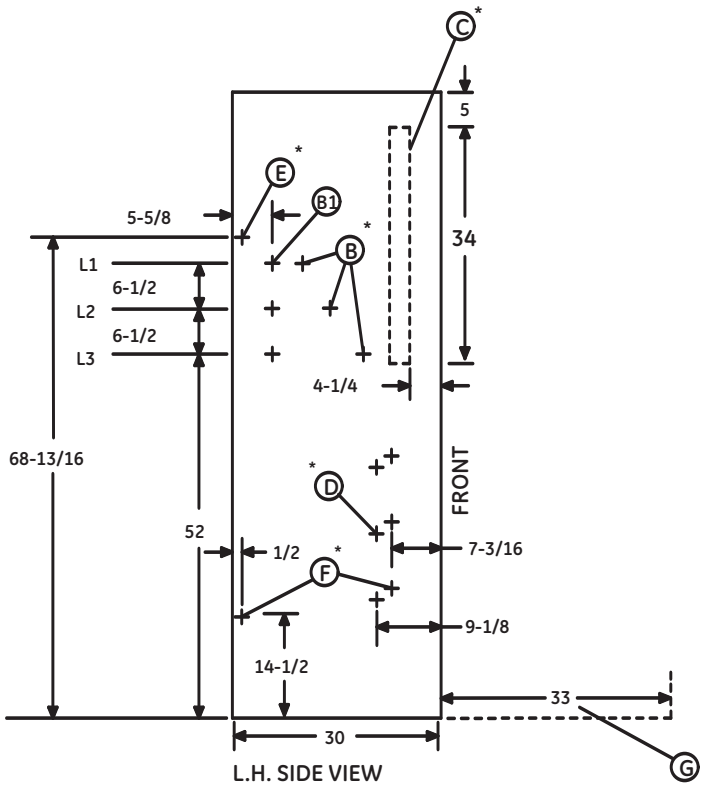

- Notes:**
- B1 — AC Power Bus
 - C — Control Lead Terminal Board
 - D — Motor Lead Terminal Connection
 - E — Ground Bus Terminal Connection
 - F — Ground Terminal Connection (if ordered)
 - G — Space Required to Open Doors 90°
 - H — Four-foot Aisle for Contactor Removal
 - J — Mounting Holes for 1/2" Diameter Anchor Bolts
 - K — Space Available for Incoming Conduit
 - M — Recommended Position for Incoming Motor Conduit
 - N — Recommended Position for Incoming Control Conduit
 - P — Recommended Position for Incoming Power Conduit
 - * — Indicates Terminal Location - Approximate for Cable Length
 - ▲ — Approximate Weight

GE Limitamp® Medium Voltage Motor Control Enclosures

Enclosure Outline Dimensions 2400-4160 Volts CR194 800A, 1 high, 48" wide

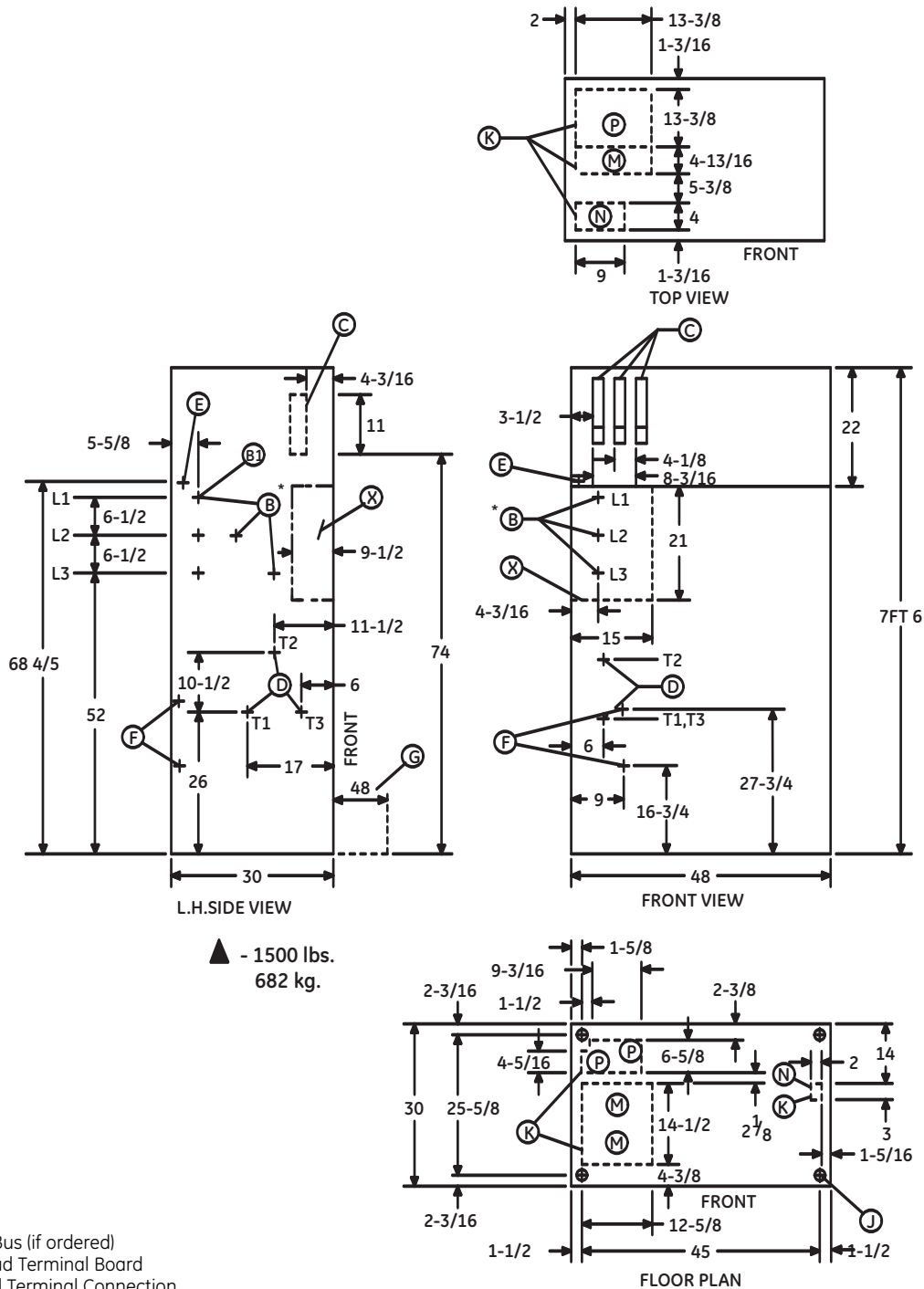

Notes:

- B1 — AC Power Bus (if ordered)
- C — Control Lead Terminal Board
- D — Motor Lead Terminal Connection
- E — Ground Bus Terminal Connection
- F — Ground Terminal Connection (if ordered)
- G — Space Required to Open Doors 90°
- H — Four-foot Aisle for Contactor Removal
- J — Mounting Holes for 1/2" Diameter Anchor Bolts
- K — Space Available for Incoming Conduit
- M — Recommended Position for Incoming Motor Conduit
- N — Recommended Position for Incoming Control Conduit
- P — Recommended Position for Incoming Power Conduit
- * — Indicates Terminal Location - Approximate for Cable Length
- ▲ — Approximate Weight

GE Limitamp® Medium Voltage Motor Control Enclosures

Enclosure Outline Dimensions 2400-4160 Volts CR194 400A, 1 high, 36" wide non-walk-in (stationary or draw-out)

E

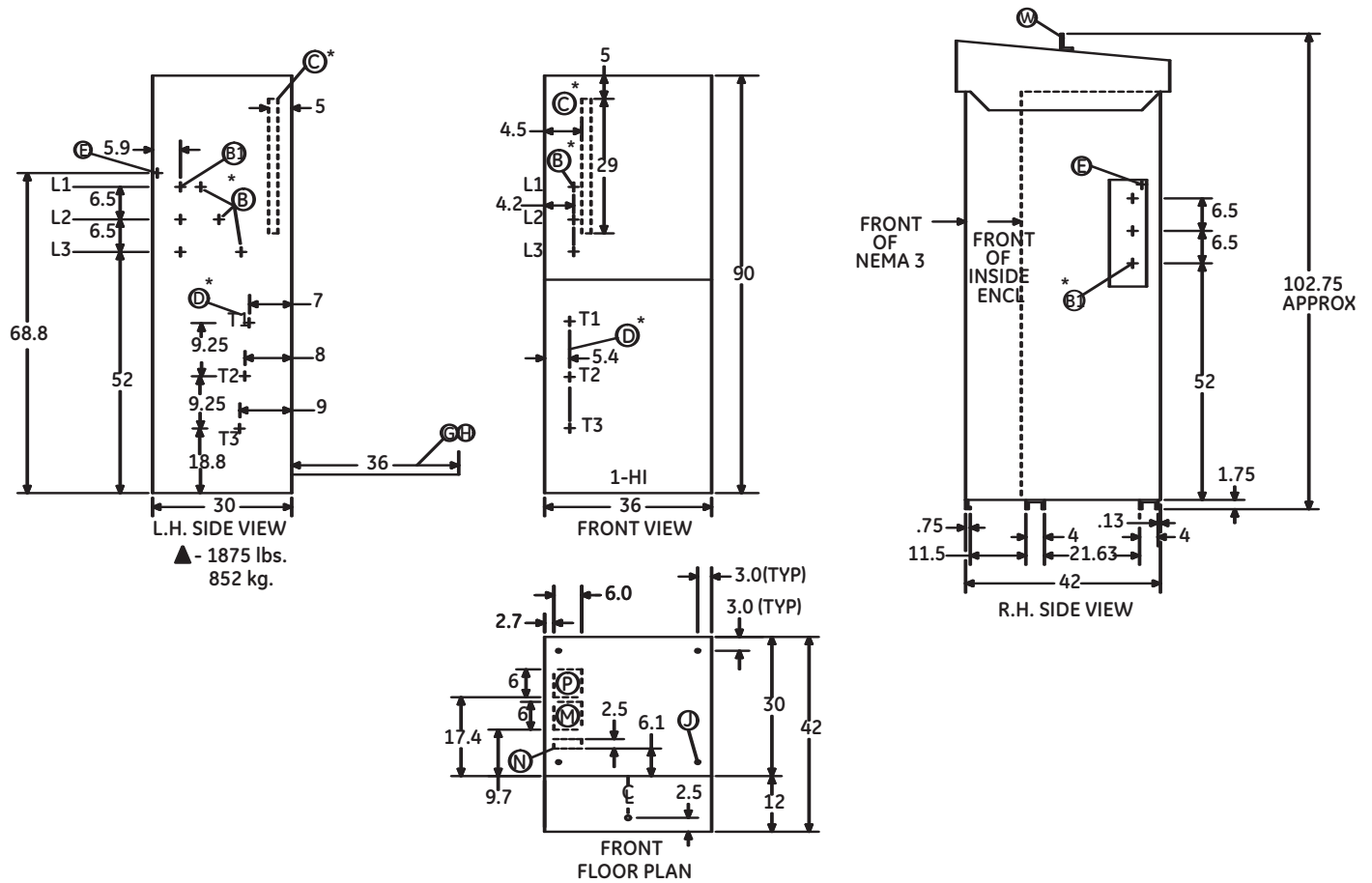

Notes:

- B — Incoming Power Terminal Connection
- B1 — AC Power Bus
- C — Control Lead Terminal Board
- D — Motor Lead Terminal Connection
- E — Ground Bus Terminal Connection
- F — Ground Terminal Connection (If Ordered)
- G — Space Required to Open Doors 90°
- H — Aisle for Contactor Removal
- J — Mounting Holes for 1/2" Diameter Anchor Bolts
- K — Space Available for Incoming Conduit
- M — Recommended Position for Incoming Motor Conduit
- N — Recommended Position for Incoming Control Conduit
- P — Recommended Position for Incoming Power Conduit
- * — Indicates Terminal Location - Approximate for Cable Length
- ▲ — Approximate Weight

GE Limitamp® Medium Voltage Motor Control Enclosures

Enclosure Outline Dimensions 2400-4160 Volts CR194 400A, 1 high, 40" wide non-walk-in (stationary or draw-out)

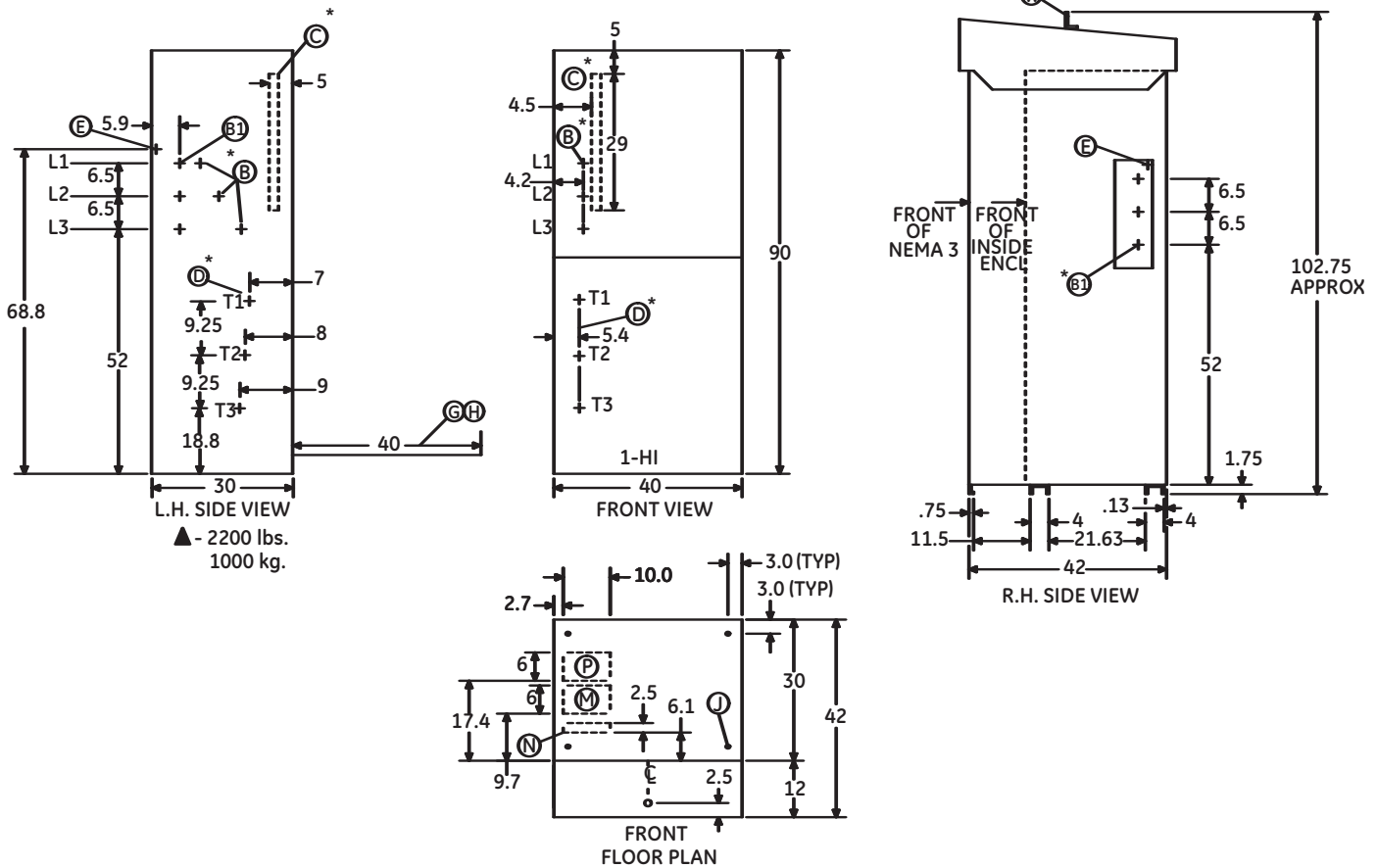

Notes:

- B — Incoming Power Terminal Connection
- B1 — AC Power Bus
- C — Control Lead Terminal Board
- D — Motor Lead Terminal Connection
- E — Ground Bus Terminal Connection
- F — Ground Terminal Connection (If Ordered)
- G — Space Required to Open Doors 90°
- H — Aisle for Contactor Removal
- J — Mounting Holes for 1/2" Diameter Anchor Bolts
- K — Space Available for Incoming Conduit
- M — Recommended Position for Incoming Motor Conduit
- N — Recommended Position for Incoming Control Conduit
- P — Recommended Position for Incoming Power Conduit
- * — Indicates Terminal Location - Approximate for Cable Length
- ▲ — Approximate Weight

GE Limitamp® Medium Voltage Motor Control Enclosures

Enclosure Outline Dimensions 2400-4160 Volts CR194 400A, 1 high, 36" wide walk-in (stationary or draw-out)

E

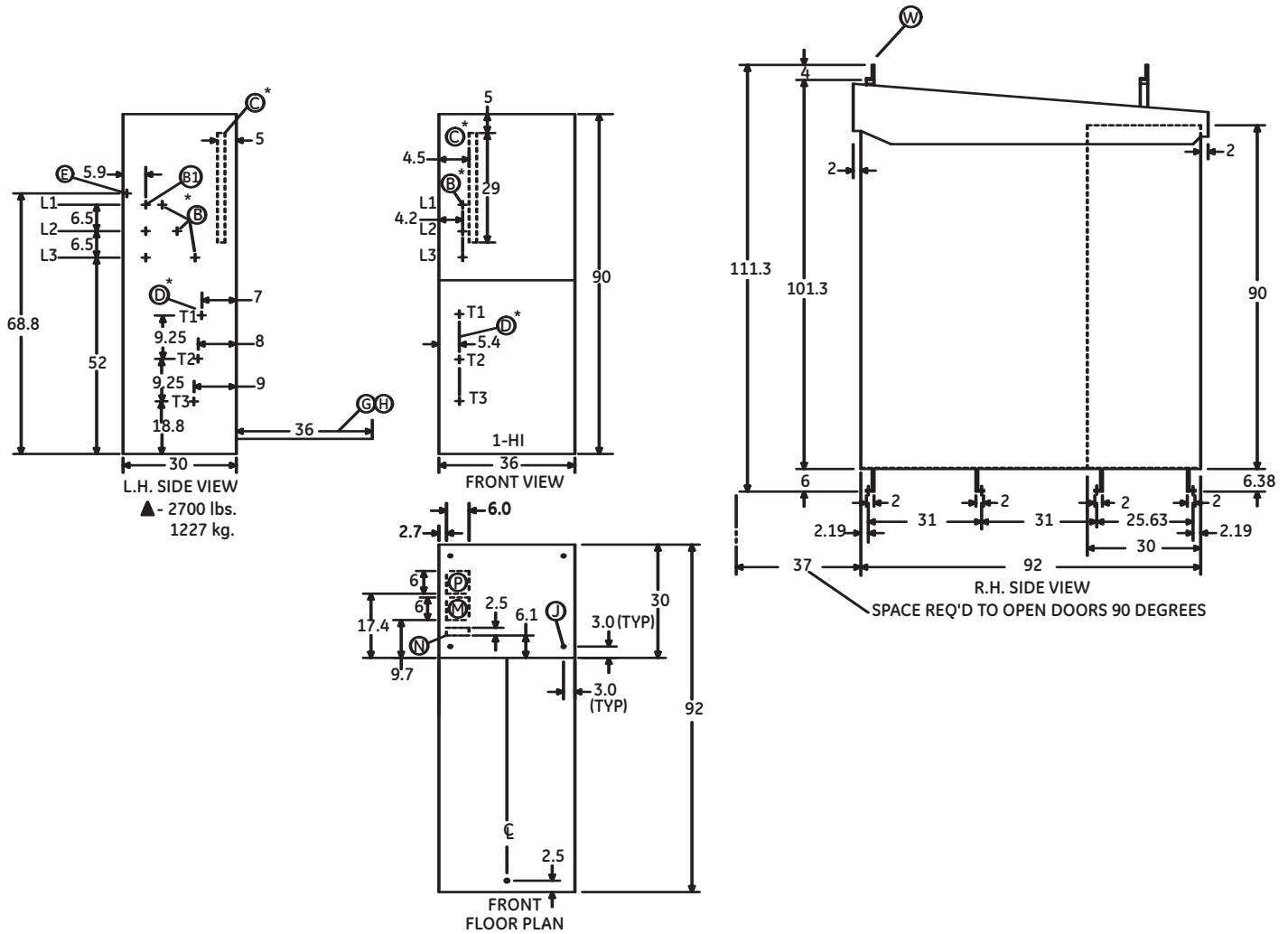

Notes:

- B — Incoming Power Terminal Connection
- B1 — AC Power Bus
- C — Control Lead Terminal Board
- D — Motor Lead Terminal Connection
- E — Ground Bus Terminal Connection
- F — Ground Terminal Connection (If Ordered)
- G — Space Required to Open Doors 90°
- H — Aisle for Contactor Removal
- J — Mounting Holes for 1/2" Diameter Anchor Bolts
- K — Space Available for Incoming Conduit
- M — Recommended Position for Incoming Motor Conduit
- N — Recommended Position for Incoming Control Conduit
- P — Recommended Position for Incoming Power Conduit
- * — Indicates Terminal Location - Approximate for Cable Length
- ▲ — Approximate Weight

GE Limitamp® Medium Voltage Motor Control Enclosures

Enclosure Outline Dimensions 2400-4160 Volts CR194 400A, 1 high, 40" wide walk-in (stationary or draw-out)

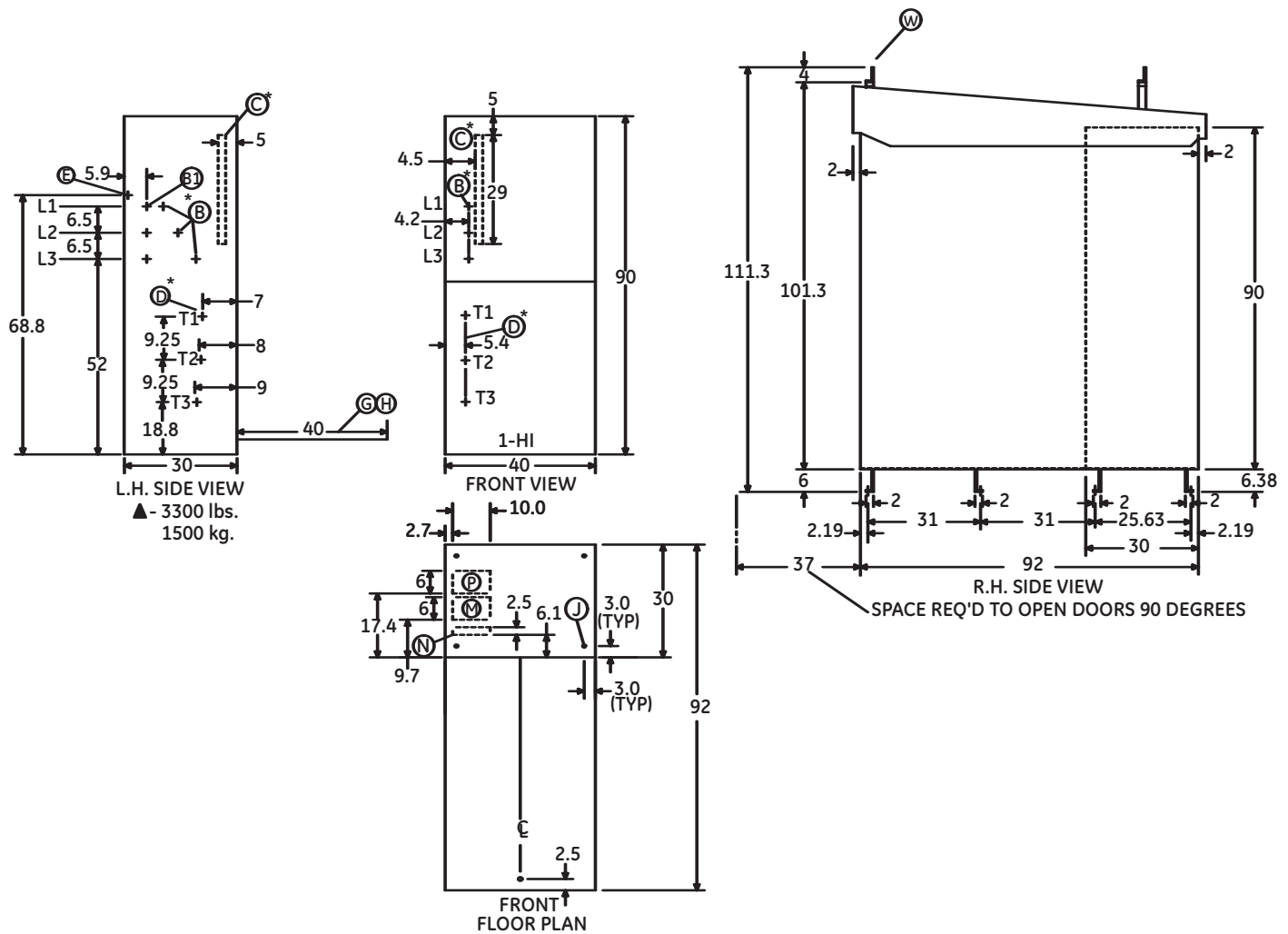

Notes:

- B — Incoming Power Terminal Connection
- B1 — AC Power Bus
- C — Control Lead Terminal Board
- D — Motor Lead Terminal Connection
- E — Ground Bus Terminal Connection
- F — Ground Terminal Connection (If Ordered)
- G — Space Required to Open Doors 90°
- H — Aisle for Contactor Removal
- J — Mounting Holes for 1/2" Diameter Anchor Bolts
- K — Space Available for Incoming Conduit
- M — Recommended Position for Incoming Motor Conduit
- N — Recommended Position for Incoming Control Conduit
- P — Recommended Position for Incoming Power Conduit
- * — Indicates Terminal Location - Approximate for Cable Length
- ▲ — Approximate Weight

GE Limitamp® Medium Voltage Motor Control Enclosures

Enclosure Outline Dimensions 2400-4160 Volts

CR194 400A, 1 high, 34" wide & CR194 800A, 1 high, 48" wide non-walk-in

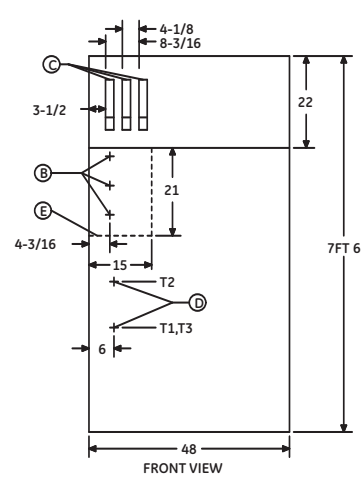
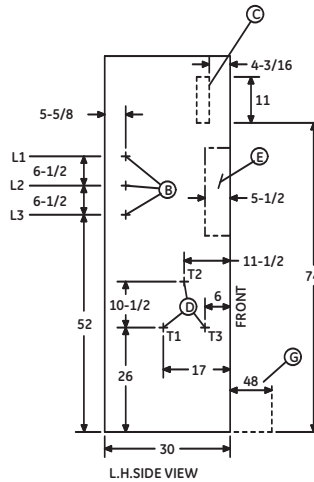
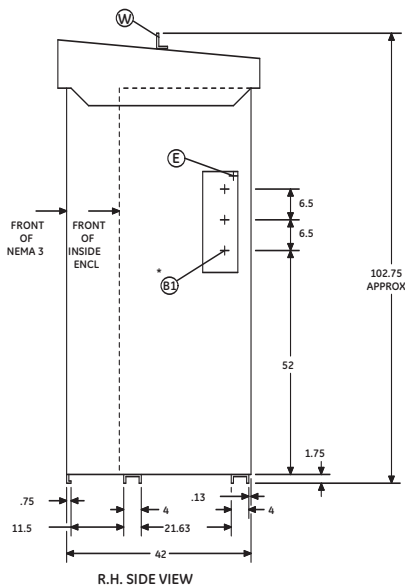

▲ - 1500 lbs.
682 kg.

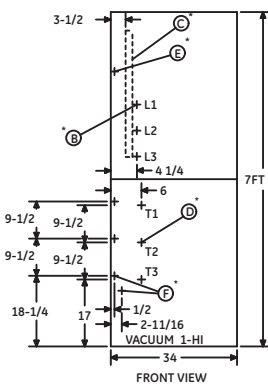
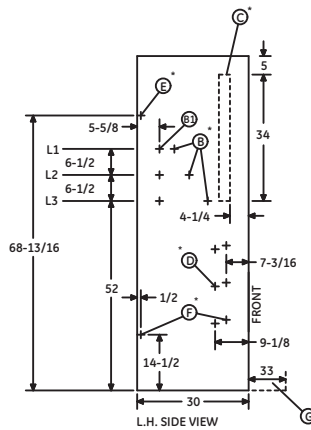
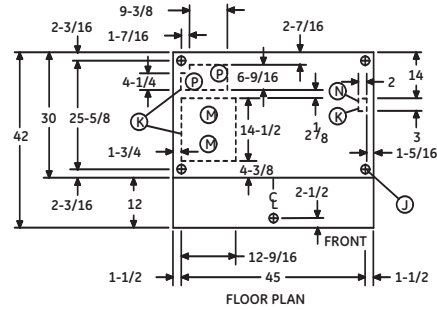

▲ - 1300 lbs.
591 kg.

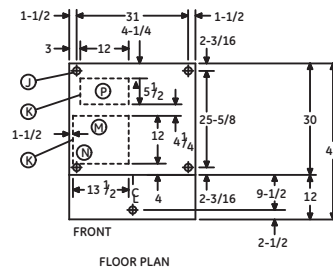

Notes:

- B1 — AC Power Bus (if ordered)
- C — Control Lead Terminal Board
- D — Motor Lead Terminal Connection
- E — Ground Bus Terminal Connection
- F — Ground Terminal Connection (if ordered)
- G — Space Required to Open Doors 90°
- H — Four-foot Aisle for Contactor Removal
- J — Mounting Holes for 1/2" Diameter Anchor Bolts
- K — Space Available for Incoming Conduit
- M — Recommended Position for Incoming Motor Conduit
- N — Recommended Position for Incoming Control Conduit
- P — Recommended Position for Incoming Power Conduit
- W — Lifting Angle
- * — Indicates Terminal Location - Approximate for Cable Length
- ▲ — Approximate Weight

GE Limitamp® Medium Voltage Motor Control Enclosures

Enclosure Outline Dimensions 2400-4160 Volts CR194 400A, 1 high, 26" & 34" wide walk-in

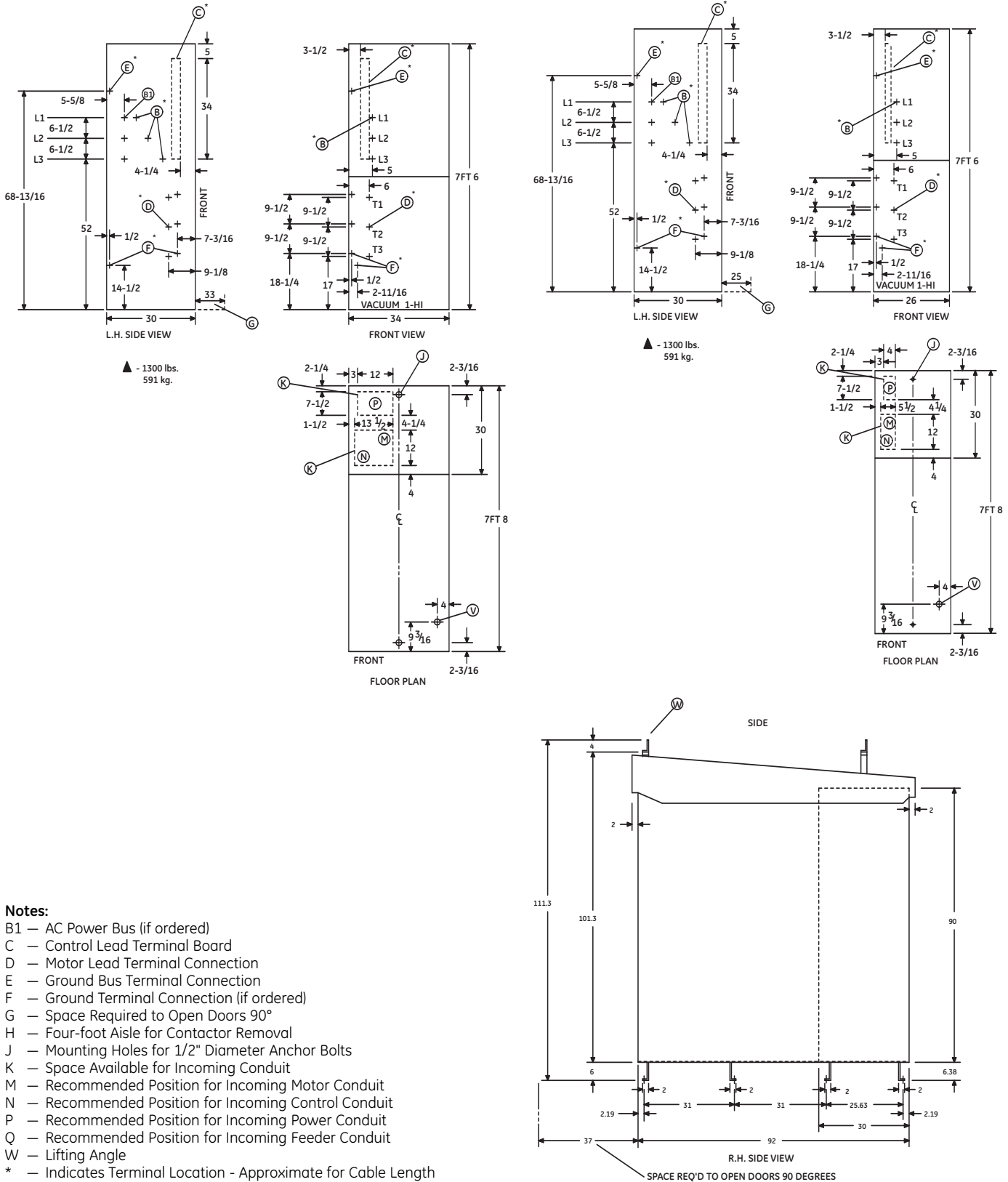

- Notes:**
- B1 — AC Power Bus (if ordered)
 - C — Control Lead Terminal Board
 - D — Motor Lead Terminal Connection
 - E — Ground Bus Terminal Connection
 - F — Ground Terminal Connection (if ordered)
 - G — Space Required to Open Doors 90°
 - H — Four-foot Aisle for Contactor Removal
 - J — Mounting Holes for 1/2" Diameter Anchor Bolts
 - K — Space Available for Incoming Conduit
 - M — Recommended Position for Incoming Motor Conduit
 - N — Recommended Position for Incoming Control Conduit
 - P — Recommended Position for Incoming Power Conduit
 - Q — Recommended Position for Incoming Feeder Conduit
 - W — Lifting Angle
 - * — Indicates Terminal Location - Approximate for Cable Length
 - \blacktriangle — Approximate Weight

GE Limitamp® Medium Voltage Motor Control Enclosures

Enclosure Outline Dimensions 2400-4160 Volts CR194 800A, 1 high, 48" wide walk-in (stationary or draw-out)

E

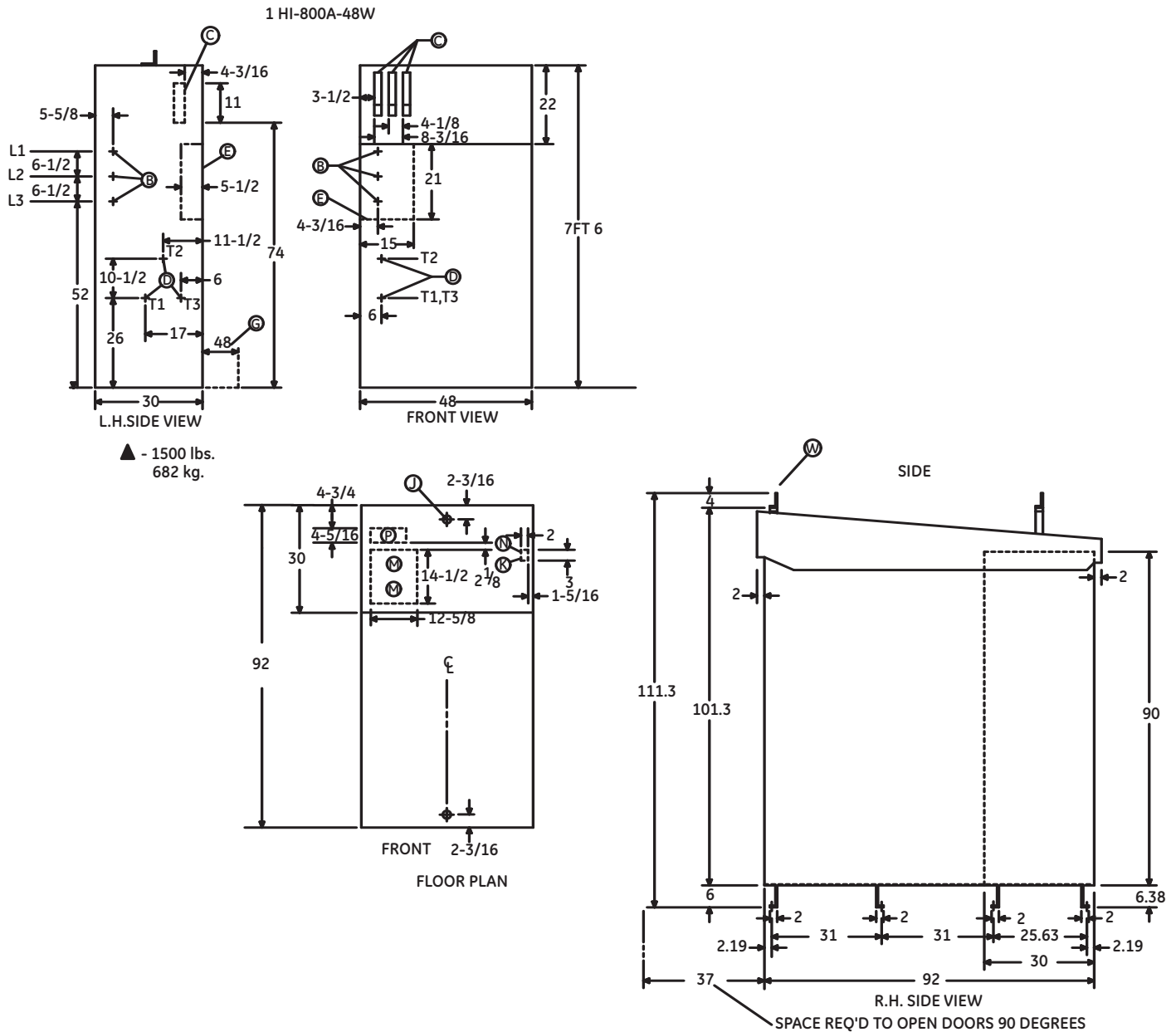

Notes:

- B1 — AC Power Bus (if ordered)
- C — Control Lead Terminal Board
- D — Motor Lead Terminal Connection
- E — Ground Bus Terminal Connection
- F — Ground Terminal Connection (if ordered)
- G — Space Required to Open Doors 90°
- H — Four-foot Aisle for Contactor Removal
- J — Mounting Holes for 1/2" Diameter Anchor Bolts
- K — Space Available for Incoming Conduit
- M — Recommended Position for Incoming Motor Conduit
- N — Recommended Position for Incoming Control Conduit
- P — Recommended Position for Incoming Power Conduit
- Q — Recommended Position for Incoming Feeder Conduit
- W — Lifting Angle
- * — Indicates Terminal Location - Approximate for Cable Length
- ▲ — Approximate Weight

GE Limitamp® Medium Voltage Motor Control Enclosures

Enclosure Outline Dimensions 2400-4160 Volts 1200A & 600A, 1 high, 38" wide

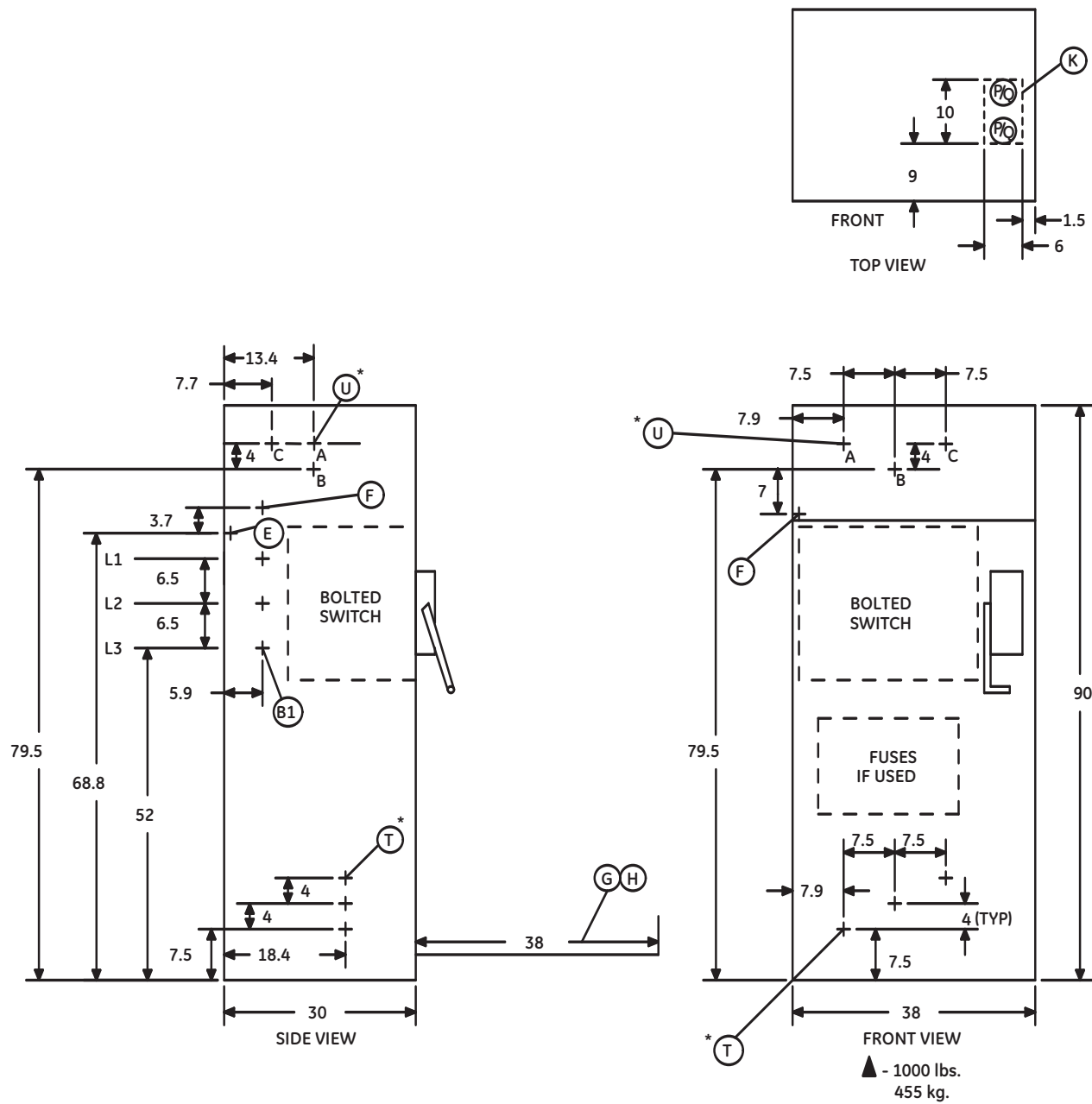

Notes:

- B1 — AC Power Bus (if ordered)
- C — Control Lead Terminal Board
- D — Motor Lead Terminal Connection
- E — Ground Bus Terminal Connection
- F — Ground Terminal Connection (if ordered)
- G — Space Required to Open Doors 90°
- H — Four-foot Aisle for Contactor Removal
- J — Mounting Holes for 1/2" Diameter Anchor Bolts
- K — Space Available for Incoming Conduit
- M — Recommended Position for Incoming Motor Conduit
- N — Recommended Position for Incoming Control Conduit
- P — Recommended Position for Incoming Power Conduit
- Q — Recommended Position for Incoming Feeder Conduit
- W — Lifting Angle
- * — Indicates Terminal Location - Approximate for Cable Length
- \blacktriangle — Approximate Weight

GE Limitamp® Medium Voltage Motor Control Enclosures

Enclosure Outline Dimensions 2400-4160 Volts 600A, 2 high, 44" wide non-walk-in

E

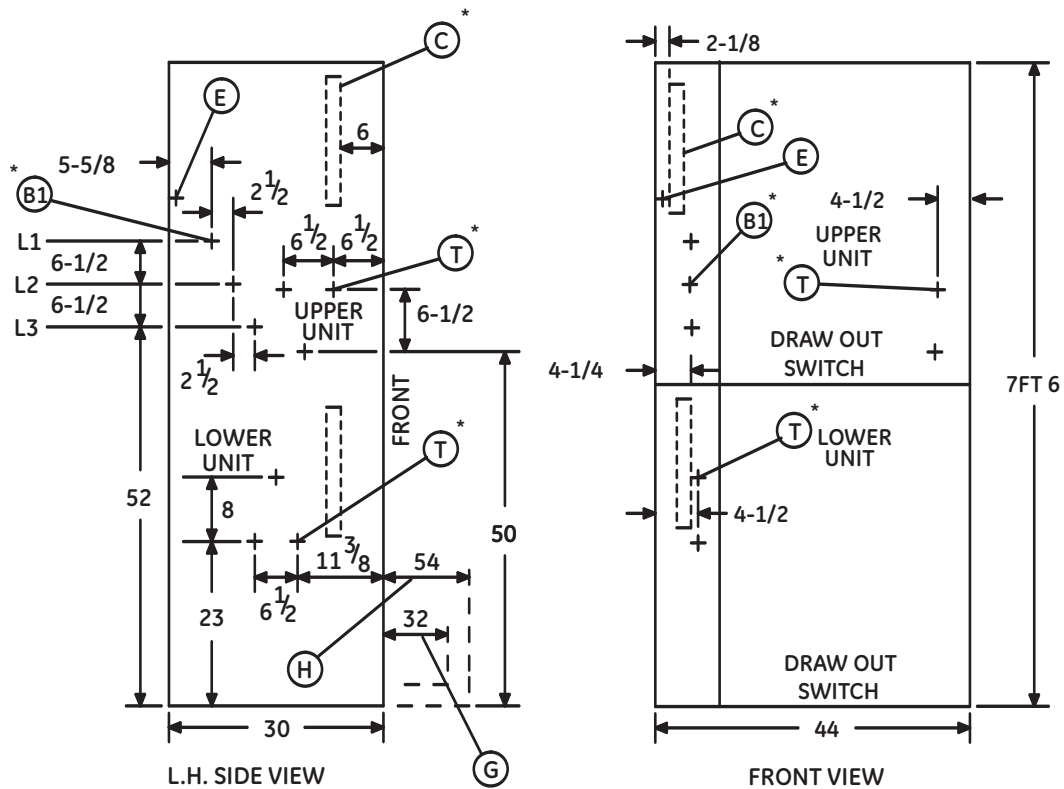

▲ - 2000 lbs.
909 kg.

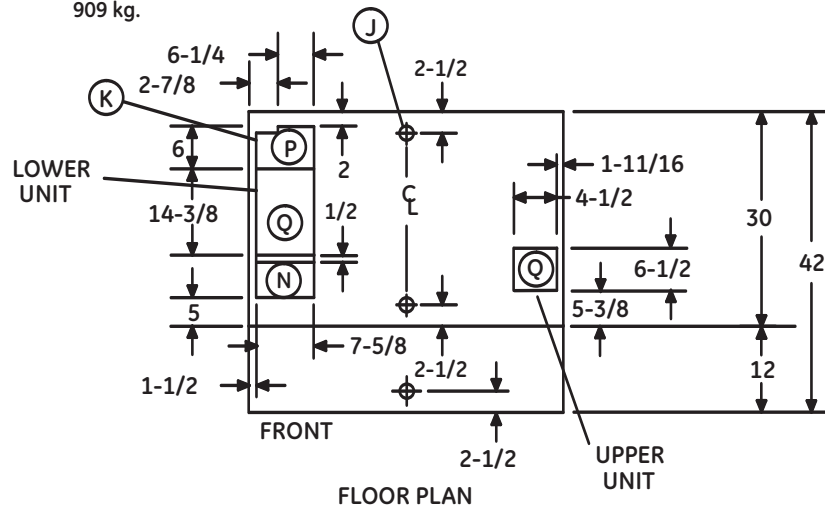

Notes:

- B1 — AC Power Bus (if ordered)
- C — Control Lead Terminal Board
- D — Motor Lead Terminal Connection
- E — Ground Bus Terminal Connection
- F — Ground Terminal Connection (if ordered)
- G — Space Required to Open Doors 90°
- H — Four-foot Aisle for Contactor Removal
- J — Mounting Holes for 1/2" Diameter Anchor Bolts
- K — Space Available for Incoming Conduit
- M — Recommended Position for Incoming Motor Conduit
- N — Recommended Position for Incoming Control Conduit
- P — Recommended Position for Incoming Power Conduit
- Q — Recommended Position for Incoming Feeder Conduit
- W — Lifting Angle
- * — Indicates Terminal Location - Approximate for Cable Length
- ▲ — Approximate Weight

GE Limitamp® Medium Voltage Motor Control Enclosures

Enclosure Outline Dimensions 2400-4160 Volts 600A, 2 high, 44" wide walk-in

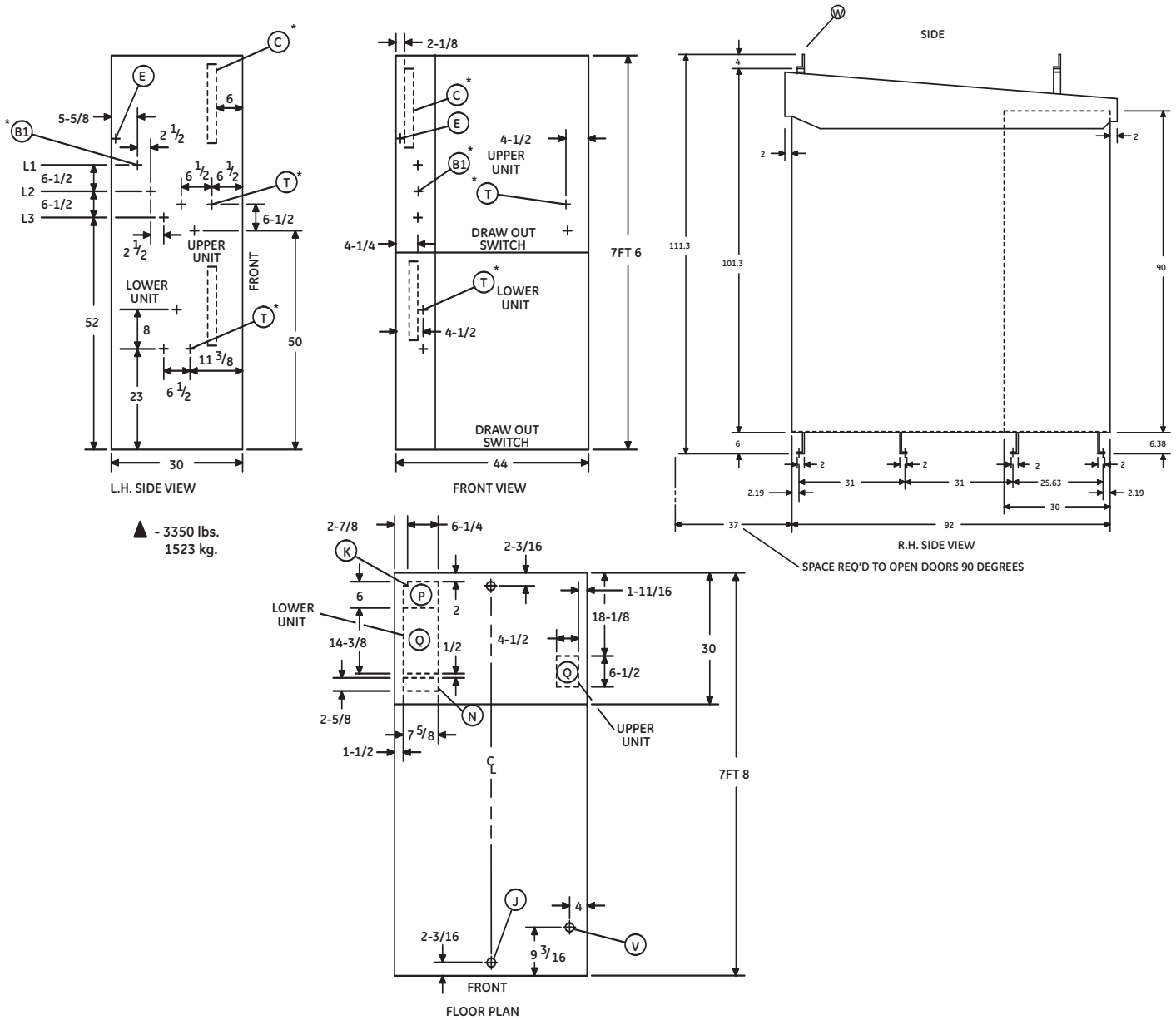

- Notes:**
- B1 — AC Power Bus (if ordered)
 - C — Control Lead Terminal Board
 - D — Motor Lead Terminal Connection
 - E — Ground Bus Terminal Connection
 - F — Ground Terminal Connection (if ordered)
 - G — Space Required to Open Doors 90°
 - H — Four-foot Aisle for Contactor Removal
 - J — Mounting Holes for 1/2" Diameter Anchor Bolts
 - K — Space Available for Incoming Conduit
 - M — Recommended Position for Incoming Motor Conduit
 - N — Recommended Position for Incoming Control Conduit
 - P — Recommended Position for Incoming Power Conduit
 - Q — Recommended Position for Incoming Feeder Conduit
 - W — Lifting Angle
 - * — Indicates Terminal Location - Approximate for Cable Length
 - \blacktriangle — Approximate Weight

GE Limitamp® Medium Voltage Motor Control Protection & Control

Fuses

Introduction

To protect the motor branch circuit against the damaging effects of short circuits, current-limiting power fuses are used in Limitamp control. They interrupt all overcurrents of magnitude greater than intended for contactor interruption. On full fault, these fuses start limiting current within the first 1/4 cycle and interrupt within the first 1/2 cycle. Because they are fast acting, these fuses are easily coordinated with system protective relaying to give selectivity in short-circuit protection.

Standard fuses supplied with Limitamp CR194 Control are bolt-in type. Clip-in fuses may be supplied in applications where motor full-load current plus service factor does not exceed 320 amperes, but they must be specified by the customer. The blown fuse indicator and the anti-single-phase trip are available with bolt-in fuses only.

Motor-starting fuses are current-limiting as indicated in Figure F.1. They melt before the current in the first major loop can reach its peak value when subjected to melting currents within the current-limiting range. Consequently, the total "let-through" energy involved is low because the fuses operate with such great speed. The contactor, current transformers, and overload relays of a Limitamp controller are coordinated with the fuses to give full protection to the system.

A design feature of motor-starting fuses inherently limits recovery voltage to safe values, thus protecting control insulation.

Controller fuses must have sufficient capacity to carry starting and full-load currents, and yet must interrupt fault currents at a desirable low value. They are therefore made in a number of ratings or sizes so that maximum protection can be obtained over a range of motor horsepower.

For a given set of motor characteristics, it is usually possible to use one of several fuses. The smallest fuses will normally be furnished. If the load is a fluctuating one, involving swings of current above full-load, the fact should be noted in specifying a controller so that a fuse one size larger than minimum will be furnished.

Transient conditions do not generally affect motor-starting fuses since the sand in the fuse conducts heat away rapidly. If transient currents do not come within 25 percent of the minimum melting curve on a time basis, melting will not occur. For example, if the melting curve for a given size fuse shows melting in 10 seconds at 1000 amperes, transient peaks of 1000 amperes would be withstood repeatedly up to 7.5 seconds duration.

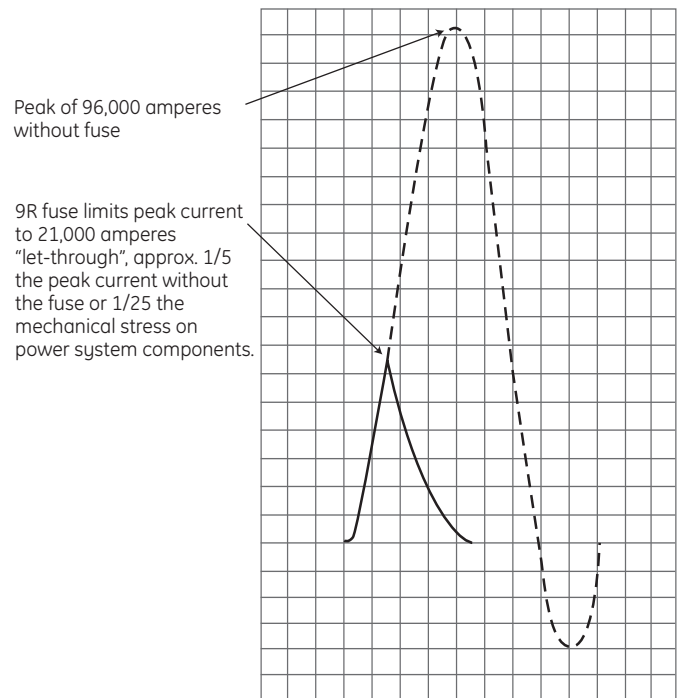

Figure F.1 Current-limiting action of typical fuse

For a lineup of controllers it may be desirable to use fuses larger than minimum size to reduce the variety of spares required. Such standardization must be specified, however.

Blown Fuse Trip And Blown Fuse Indication

The possibility of having one fuse melt, thereby causing a large motor to single phase, has inhibited consideration of fuse-contactor-type starters. Although such a condition is in reality quite unlikely, GE Limitamp Control can be equipped with an optional special mechanism which will detect a blown fuse and cause the contactor to open. Bolt-on fuses contain button indicators to show a blown fuse. This button indicator can be coupled with an anti-single-phase trip mechanism containing a control contact, which, when used in contactor control circuit, can open the contactor to prevent single phasing and/or provide a blown fuse indication on the front door. Blown fuse indication on the front door is available for CR194 equipment only.

GE Limitamp® Medium Voltage Motor Control

Protection & Control



Figure F.2 Blown fuse indicator

With this feature, fuses are always bolted in place for correct orientation and alignment. In addition to providing maximum reliability, this feature makes it impossible to mount the fuse in an upside down position which would nullify the trip bar operation.

Coordination With Other Protective Devices

When Limitamp starters are installed on a given power system, it is necessary to coordinate the time-current characteristics of system protective devices, such as Multilin Protective relays, with those of the starters. Use the time-current curves included in GE Time Current Curve No. GES-5000 for this purpose. It includes overload-relay tripping curves, fuse-melting curves and fuse-clearing time curves.

Surge Protection

The economics of rotating-machine insulation dictates that the machines be protected from voltage stresses above the operating level insofar as is reasonably possible. Overvoltage damages reduce the insulation life. There are many causes of accidental overvoltage whose effects may be reduced by protective means. The most prominent causes are:

1. Lightning.
2. Physical contact with higher voltage system.
3. Repetitive restrike (intermittent grounds).
4. Switching surges.
5. Resonance effects in series inductive capacitance circuits.

Switching transients occur in every electrical system. A well-known phenomenon associated with vacuum interrupters is current chop. GE utilizes vacuum interrupters constructed with widely accepted contact tip materials to provide low chopping currents.

Additional protection against surges for rotating machines may be economically attractive for system voltage installations of 2300 volts and above. This consists of a surge capacitor and lightning arresters.

Lightning arresters reduce the amplitude of the voltage impulse wave. The surge capacitor further reduces the amplitude — but in addition, reduces the steepness of the wave front. It is important to reduce the steepness of the

surge wave front to keep the turn-to-turn voltage stress in the machine winding to a minimum.

Surge capacitors and arresters should be installed as close to the machine terminals as possible. Capacitors and arresters may require a 22-inch wide auxiliary enclosure if installed in the controller.

Overload Relays

Several types of overload relays are used in Limitamp Control. Limitamp controllers use thermal-overload relays, unless other types are specified.

Thermal-Overload Relays

Overload relays provided in Limitamp control have inverse-time characteristics and are ambient compensated. Limitamp control utilizes either a thermal-type relay or the solid-state protective relay. These relays, operating from current transformers in the control equipment, carry current proportional to the motor-circuit current. When motor overloads occur, the relay operates to open the main power contactor. The time required for operation varies inversely with the magnitude of the overload. The standard thermal relay should only be used on motors with starting times up to 10 seconds.

External-Reset Overloads

Some industrial plants do not permit a machine operator to open the doors of control equipment enclosures, this being reserved for electricians. To make possible overload-relay reset by operators, it is therefore necessary to provide some means to do so outside the enclosing case. This is accomplished by providing a mechanical-linkage reset mechanism between the relay and door-mounted reset button.

Where external reset is not absolutely necessary, greater simplification of relay mounting results, and this is of benefit to the user because it simplifies maintenance.

Inasmuch as the tripping of an overload device is indicative of too much strain on the motor, it is preferable that only experienced and reliable personnel be allowed to reset overloads. Such personnel should be capable of realizing whether it was an unintentional overload on the part of the machine operator or whether there is an electrical and/or mechanical defect. The customer should consider this factor, however, before electing to provide externally reset overloads.

Solid-State Overload Relays

Solid-state overcurrent protection is available as an optional feature in place of standard thermal overload relays. The inverse-time characteristics can be adjusted to protect motors of various characteristics, such as long acceleration time or short allowable-stall times. Characteristics are accurate and have a smaller error band compared to bimetal relays. The solid-state overload relay is recommended for

GE Limitamp® Medium Voltage Motor Control Protection & Control

hermetically sealed air-conditioning motors, and is well suited as a stall-protection relay.

Multifunction Solid-State Relays

Large motors on vital drives need accurate protection against overloads, phase unbalance or ground faults. Multifunction solid-state relays are available from GE that offer total motor protection in one compact package. Basic protective functions such as overtemperature, overload, instantaneous overcurrent, open-phase, phase reversal, phase unbalance, ground-fault, load jam, load loss and bearing overtemperature protection can be provided.

Overtemperature Relays

Some motors have RTDs placed in the stator slots. The purpose is to obtain an indication of winding temperature by measuring the RTD resistance and its change with temperature. Difficulty arises in obtaining a continuously accurate indication of temperatures, however, because of the time lag of heat transfer from the stator conductors to the RTD caused by the insulating material surrounding the conductors. Temperature changes in the conductor will not be reflected in RTD resistance change until heat is transferred through the thermal resistance and capacitance of the insulating material.

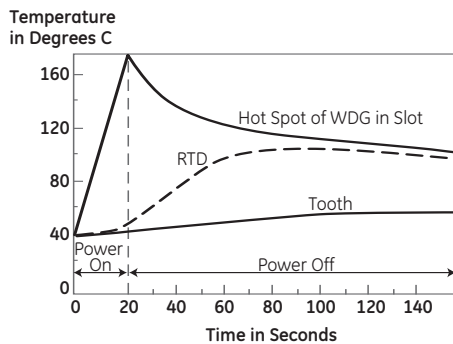

Figure F.3 Approximate temperature of RTD in large motor during locked rotor

If the copper temperature is changing very rapidly, such as during locked rotor, the RTD will lag far behind the copper temperature as shown in Figure F.4. Consequently, monitoring the RTD temperature is inadequate for thermal protection during rapid-transient conditions. However, for steady-state indication of temperature, the RTD is very accurate.

A relay which responds to changes in resistance of RTDs, providing steady-state indication of motor-winding temperature, used in conjunction with a bimetallic overload relay will provide reasonably precise over-temperature protection for the motor.

Available solid-state relays contain a device which will more accurately compute hot-spot temperature by utilizing RTD

amperes and line amperes. This relay accurately tracks motor heating and is recommended in preference to the separate bimetal relay and RTD relay.

Open-Phase And Phase-Unbalance Protection

A three-phase motor may be damaged when subjected to unbalanced line currents. Usually, the damage occurs in the rotor from overheating, caused by reverse sequence components of currents not detected by normal overload devices. The rate of motor heating will be a function of the degree of phase unbalance, the most extreme of which is the open-phase condition. For that reason, open-phase relays should operate instantaneously to avoid serious motor damage. Likewise, a motor may be damaged over a period of time with as little as 10% unbalance, where unbalance is a transient condition which would not justify instantaneous shutdown. Consequently, the time to trip should be delayed in proportion to the percentage of unbalance.

More comprehensive open-phase or single-phase protection can be obtained by applying a solid-state motor-protective relay, which will trip the contactor in the event of an open phase, regardless of the cause, even if external to the vacuum Limitamp control.

A possible concern that may arise when applying a medium-volt contactor to a transformer feeder is what happens to the contactor when a voltage dip occurs. In the past, the contactor would drop out — removing power from the primary of the transformer when the contactor coil power is reduced to 60 to 80 percent of full voltage. To prevent dropout during loss of control voltage, latching contactors should be applied. In these cases, the contactor is latched by a closing coil and unlatched by a trip coil. A capacitor trip device can be applied to trip the contactor in the event of total loss of control power. (See Latched Contactors, page B4Update reference to current page.)

Current Differential Protection

The term differential, as applied to a type of protective relaying, designates the principle on which the scheme operates — that is, a difference in current. The relays used are connected in such a way as to detect a percentage differential in current between ends of a motor winding. Ordinarily, in a machine operating without a winding fault, the current into one end of a phase winding is equal to the current out the other end of the same winding. When a fault occurs, however, the current into one end of the winding is short circuited inside the machine (to another phase or to ground) at the place of fault, so that a differential occurs between current “in” and current “out.” This causes the relay to operate. The percentage differential may at times be quite small when the fault is located at a point of high impedance inside the motor winding, and this is the reason why straight over-current relays alone do not always give adequate protection.

GE Limitamp® Medium Voltage Motor Control

Protection & Control

The cost of this type of relaying is justified by the size of the investment to be protected. Large motors (usually above 1500 hp) that are expensive to repair or replace often employ differential relays.

Specifically, differential relays accomplish the following:

1. Provide for power interruption to a motor in the event of a phase-to-phase insulation failure in the motor windings.
2. Provide for power interruption to a motor in the event of a phase-to-ground fault in the motor winding.

The primary use of differential relays in Limitamp Controllers is to give fast, sensitive protection for faults in the end turn outside the stator punchings. Such faults are relatively rare compared with ground faults. However, when they do occur, the presence of differential relays would probably mean the difference between minor and extensive damage.

Two methods of motor differential protection are available. One uses six identical current transformers: three located in the motor leads and three located in the wye points of the motor windings, usually at the motor. In conjunction with these six current transformers, a Multilin SR469 or similar relay is used to detect the difference in current in the current transformer (CTs). The other method, known as self-balancing, uses three donut-type CTs. Both the motor leads and the wye connections are brought back through the holes in the donut CTs. For this system, Multilin SR469 relay can be used

Ground-Fault Relays

Ground fault relays are justified economically for all motors rated 2300 to 7200 volts, 150 horsepower and above. The purpose is to provide interruption of power to the motor as rapidly as is practical after positive indication that a ground fault has occurred. Most multifunction relays such as Multilin SR369/469 offer ground fault protection as a standard. Refer to component brochures for further details.

The time of interruption of ground-fault current is dependent on several factors:

1. Sensitivity of the ground-fault relay.
 - (a) Instantaneous type
 - (b) Time-delay type
2. Magnitude of ground current.
3. Clearing time of the power interrupter.

The importance of clearing ground-fault current rapidly cannot be overstressed. Ground current inside rotating machines causes damage to the lamination which, if not interrupted rapidly, necessitates complete disassembly and repair of the motor.

Although most ground-fault relays are now of the instantaneous type, few applications do require inverse-time current relays for coordination and selectivity reasons. The use of

instantaneous-type relays is made possible through the employment of a zero-sequence window-type current transformer installed in the starter in such a way as to permit all three conductors of the three-phase line to be used as the current-transformer primary.

Phase currents add to algebraic zero, regardless of magnitude, and no secondary current flows except that induced by the primary current going to ground. This system gives positive indication of ground current, eliminates false tripping and permits instantaneous relaying.

If time coordination with other ground-fault relays is necessary, time overcurrent relays may be used in the current-transformer arrangement.

For certain sized motors where the power system permits, ground-fault relays may be used as a less expensive alternative to differential relays. Most phase-to-phase winding faults detected by differential relays result in a simultaneous phase-to-ground fault, thereby operating the ground fault relay. For that reason, ground fault relays may be used as a less expensive alternative to differential relays.

Another method of detecting ground currents in a three-phase system employs three separate line-current transformers, one in each phase, with the secondaries fed through a single current relay. In this system, the secondary currents should sum to zero just as they do in the primary of the window type current transformer. And, with no ground current flowing, the three secondary currents do add and cancel each other out. Ground current only will cause the relay to operate. For currents of large magnitude, however, such as motor locked-rotor current, current-transformer saturation becomes a problem, causing residual current to flow in the relay coil... resulting in false tripping. To prevent false tripping with the residual connection, time-delay relays are necessary to permit riding over the starting period of the motor. This fact makes instantaneous relays impractical in the residual system.

Instantaneous ground-fault relays may be applied to Limitamp (NEMA Class E2) controllers without limitation on available ground current. The fuse and relay-contactor clearing times are such that ground-fault currents up to and including the fuse rating will be cleared without damage to the controller.

Standard ground-fault relay used in Vacuum Limitamp Control is a solid-state relay which operates on approximately 4 to 12 amperes ground-fault current. If greater sensitivity is required, other solid-state ground-fault relays may be furnished which can be adjusted to trip as low as 1 ampere. However, extreme care must be exercised in applying ground-fault relays of such low pick up. They could trip falsely on system-charging current. A magnetic ground-fault relay can be provided on request.

GE Limitamp® Medium Voltage Motor Control

Protection & Control

Undervoltage Protection

NEMA defines undervoltage protection as a device whose principal objective is to prevent automatic restarting of equipment.

Instantaneous undervoltage protection is inherent to the standard 3-wire control circuits, since the contactor will drop out and stay out on loss of voltage.

Time-Delay

Time delay undervoltage protection (TDUV) for a Limitamp controller can be provided to prevent shut-down of a motor on adjustable duration voltage dips below the adjustable dropout voltage. With either time-delay or the standard instantaneous undervoltage protection, the motor remains disconnected until the operator restarts the motor.

Automatic Restart

GE offers an auto-restart relay which automatically restarts the motor following a momentary outage. It also can be set to delay contactor reclosure following power restoration so the motor is not re-energized out-of-phase due to residual field or cage rotor currents,

Ride Through

This optional feature provides control to maintain a standard electrically-held contactor in the closed position through momentary control voltage outages up to 20 cycles (333 milliseconds). Also, protective relay operation and/or normal stop control is configured to allow the contactor to open without the ride-through delay.

Synchronous-Motor Control and Excitation

Synchronous Motor Control

GE Limitamp synchronous-motor controllers are offered for both brush-type and brushless synchronous motors. As a standard, both brush-type and brushless synchronous motor controllers are equipped with the GE-Multilin SPM solid-state field application and protection module. This microprocessor-based module provides basic synchronous motor control and protection functions including squirrel-cage starting protection, power factor and pull-out running protection, and field application control to maximize pull-in torque (for brush-type machines only). Digital displays of motor running line current and power factor are featured along with a keypad for entering set-point parameters. Available options are field loss protection, exciter voltage check protection, field amps display, exciter volts display, incomplete sequence protection, and power factor regulation (when used with compatible SCR type variable field exciters).

Exciters For Brush Type Motors

For synchronous motors equipped with sliprings and brushes,

Limitamp is offered with a variety of excitation options. Single-phase solid-state exciters can be integrated in the controller NEMA 1 ventilated enclosure up to 9 kW (exciters must be derated for non-ventilated enclosures). Larger exciters require auxiliary enclosures that can be placed in the common bussed line-up with the Limitamp controllers. Two basic types of exciters are available:

- SFC (fixed excitation with adjustable tapped transformer)
- VFC (on-line adjustable excitation by manual or automatic means)

Fixed Excitation

The basic exciter offering is a single-phase, tapped-transformer, static field contactor (SFC). The SFC is a solid-state switching device consisting of silicon controlled rectifiers (SCRs) in a bridge circuit for rectification of AC power to DC. Additional SCRs are provided to switch the field discharge resistor. During starting, the SFC switches the field discharge resistor on so that the induced field current from the motor field is passed through the discharge resistor. The field discharge resistor is also switched on to discharge the field current when DC is removed at motor shutdown and if, during normal motor operation, the motor field generates a high voltage surge above approximately 600 volts, such as would occur if the motor "slips" a pole. When the motor has accelerated to near synchronous speed, the GE-Multilin SPM module signals the SFC to apply DC to the motor field, the SFC switches the field discharge resistor off and causes the SCRs in the rectifier bridge to turn on, resulting in DC being applied to the motor field. The bridge SCRs are gated "full on" so that they emulate a diode rectifier bridge. The voltage of this DC field supply is determined by the tap connection of the customized transformer that feeds AC power to the rectifier bridge. This transformer has secondary taps arranged so that the DC voltage can be adjusted in 5% increments from 70% to 130% of the transformer nominal secondary voltage by changing connections at the transformer tap.

Variable Excitation

Another exciter offering is the electronic variable field contactor (VFC). The VFC is available in single- or three-phase versions. Three phase VFC exciters are recommended for sizes 20 kW and above (125 VDC fields), and 25 kW and above (250 VDC fields). Like the SFC (above), the VFC controls the switching of the field discharge resistor and DC to the field depending on inputs from the GE-Multilin SPM. The difference is that the gating of the rectifier bridge SCRs can be controlled by varying an analog voltage at its control input. This allows on-line control of the DC exciter voltage by any of several means:

1. Manual control via a door-mounted potentiometer.
2. Automatic control via the field current regulation module.
3. Automatic control via the GE-Multilin SPM equipped with power factor regulation.

GE Limitamp® Medium Voltage Motor Control

Protection & Control

On-Line Field Adjustment

The manual potentiometer is normally mounted on the door and allows an operator to adjust the motor field current while the motor is running. This provides the convenience over the SFC type exciter of not having to shut down the motor and physically move cables between several taps on the exciter transformer.

Field Current Regulation

The field current regulator module also employs a manual potentiometer for adjustment of the field current. However, the regulator provides a closed loop control so that the VFC DC output is automatically adjusted to maintain the set-point field current as set by the manual potentiometer. This feature allows the operator to set the field one time at a desired field current. The field current will then be regulated to compensate for field resistance changes due to field winding heating or system voltage fluctuations. The leading reactive power contribution of a synchronous motor is related to the level of field current. If it is desired to maximize the contribution of leading reactive power from the synchronous motor at all shaft loading conditions, set the field current as high as possible without exceeding its nameplate rating. Field current regulation is the ideal choice for maximizing the leading reactive power because it allows the operator to set the field current very close to rated and not worry about the current “creeping” higher or lower from the potentiometer setting.

Power Factor Regulation

Power factor regulation is an excellent choice for applications requiring field forcing, which is applying DC excitation above its rating for a short time. Many drives, such as chippers, are subject to transient impact overloads many times the motor rating for short time intervals. By forcing the field, the synchronous motor can be enabled to deliver shaft torques above the rating without “pulling-out” of synchronism and shutting down. GE tests on chipper drives have demonstrated that the power factor regulation option can provide the rapid field forcing feature to prevent disruptive motor “pull-out.” Power factor regulation operates on the principle that the motor running power factor is a good predictor of motor pull out. Before a motor pulls out of step (as a result of high shaft loading from a hard or oversized log entering a chipper), the power factor dips in the lagging direction drastically. By setting the regulator such that it boosts excitation as the power factor dips more lagging than the regulator set point, the motor running power factor is held to a “healthy” level and motor “pull-out” is avoided. Power factor regulation also allows the field excitation power to be conserved when the motor is running lightly loaded or unloaded. This not only allows energy conservation but also deeper no-load cooling of the motor windings, so the motor runs cooler for a given level of RMS loading. Power factor regulation can help regulate the power system voltage by minimizing reactive power swings over a wide range of motor loads.

Brushless Synchronous Control

The GE-Multilin SPM is also designed for use with brushless synchronous motors. It provides timed field exciter application, power factor and pull-out protection and starting/stall protection. Included with the standard brushless synchronous motor Limitamp controller is a variable exciter field supply consisting of a door mounted variable autotransformer and rectifier for on-line exciter voltage control.

Fixed-Tap Field Resistor

A fixed-tap field resistor may be used for separate DC source. This resistor, when supplied with the Limitamp panel, is mounted on top and is connected directly in series with the synchronous-motor field as a means of adjusting field current. The resistor is continuously rated with taps to adjust field current 10-percent above and below rated full-load field current for rated power factors in approximately 2 1/2-percent steps.

Other Options

Exciter Voltage Check Protection, field circuit continuity check protection and field ground protection are also available on some applications.

Control Circuits

Control Power Transformer

Control power transformers used in Limitamp starters are single-phase, air-cooled, core-and-coil construction with high-voltage windings covered to prevent contamination by dust and dirt. Those furnished in standard panels have a 25-kV Basic Impulse Level (BIL) rating. 750VA is standard in a basic controller. Transformers 2 kVA and above are optional, and above 3 kVA may require an auxiliary enclosure for mounting.

When specified, a 500VA, 60-kV BIL rated control transformers can be furnished, but will require special space consideration.

Omission Of Control Power Transformer

A lineup of starters can use a common control power transformer or other source of control power. In either case, the power source and control circuit must be provided with interlocking relays so the loss of either will shut down all operating motors. Control bus is required in all controllers if a common source of control power is used.

A single source of control power results in some disadvantages: (1) Unless each panel is provided with a fused control switch, troubleshooting must be done with live wires in the panel; (2) a single controller, if relocated independent of the lineup, will require modification to add a control transformer and fuses; and (3) the loss of control power will cause shutdown of all machines.

Timing Relays

Solid State and or Electronic timing relays close or open a

GE Limitamp® Medium Voltage Motor Control

Protection & Control

circuit after a definite elapsed time on either energization or de-energization.

Incomplete-Sequence Relay

An incomplete-sequence relay is used to shut down the motor (squirrel-cage induction or synchronous) on reduced-voltage starting if the control fails to transfer to full voltage. This standard feature protects the autotransformer from energization longer than rated time. The relay can be furnished for other sequencing functions also.

Jogging

Drives requiring “jogging” (or inching) must have the control circuit arranged for repeatedly closing the line contactor at short intervals to effect small movements of the driven machine. The line contactor is held closed only as long as the JOG button is held depressed.

An anti-kiss circuit is provided with the JOG push button, including a jog relay. The jog relay closes when the JOG button is depressed, energizes the line contactor coil, seals itself in around the JOG button and is dropped out only after the line contactor has closed and wiped in. This makes possible repeated opening and closing of the line contactor, but also assures that the tips wipe closed each time.

Current Interlocking

Current-operated relays indicate when the arc is completely extinguished after the line contactor opens. These relays then permit closure of a reversing contactor. A short circuit may occur if a reversing contactor closes after the forward contactor opens but before the arc has been extinguished. This circuit is necessary in controllers with “plug stop” or where pressing one instantaneous contact picks up reversing contactor while running forward. Current interlocking is not normally used on overhauling loads such as mine hoists, since during the lowering cycle enough current may not be drawn to operate the interlocking relays.

This circuit is not supplied on standard Limitamp reversing controllers, as the operator is expected to turn the selector switch to reverse only after pressing the STOP button.

Potential Interlocking

Potential interlocking is used for the same reason as in current interlocking. Potential transformers and interlocking relays are added to prevent closure of one primary contactor before complete interruption of the arcs at the tips of the other (reverse) contactor. Operation is based on the principle that by the time the disconnected motor's generated EMF has decayed to the point where the interlocking relays have dropped out, the arc in the disconnected contactor has extinguished, and closing the reversing contactor is permissible.

Potential interlocking is used on hoists and other applications having possible overhauling loads.

Instrumentation

Ammeter

An ammeter (panel-type or switchboard-type) is used to indicate either motor amperes or total incoming amperes. It can either be hardwired to the current transformer of one phase or all three phases can be monitored by the use of a selector switch. One current transformer is required for single-phase reading; two are required for open delta three-phase reading; three are required in a wye circuit. Three window-type current transformers are provided as standard on Limitamp Controllers.

Voltmeter

The voltmeter (panel-type or switchboard-type) is used to indicate phase-to-phase potential. One potential transformer is required if only one phase-to-phase potential is monitored. Two potential transformers, connected in an open-delta configuration, are required along with a selector switch to monitor any one of the three phases. Three potential transformers mounted in an auxiliary enclosure and a selector switch are required to read both phase-to-phase and phase-to-neutral potentials.

Power Factor Meter

A power factor meter is used to indicate power factor lead or lag. It is useful in adjusting power factor in synchronous motor drives and in determining the power factor of a given drive. The addition of a power factor meter requires the addition of potential transformers, or of some other potential source with correct phase and accuracy. When a synchronous starter is supplied, the GE-Multilin SPM has a digital power factor meter built into the device.

Wattmeter

A wattmeter is used to indicate loading or useful power being delivered to a drive at any instant. The instrument is typically calibrated in kilowatts. Two potential transformers connected in open delta are required for operation.

Operation Counter

The operation counter is electrically operated from a control interlock on the line contactor. It totals the number of times the contactor has closed and opened, and thus provides data for the establishment of maintenance schedules, a record of the number of batch processes initiated over a given period of time, or any other purpose where the number of line contactor closures may be significant.

Varmeter

The varmeter indicates lagging or leading reactive power. It requires the addition of two potential transformers. In totaling reactive power on a bus feeding several loads, individual vars for each load can be measured by means of individual varmeters on each motor and added directly.

GE Limitamp® Medium Voltage Motor Control Protection & Control

Elapsed Time Meter

An elapsed time meter is used to indicate hours of operation or shutdown time of a particular motor or drive for the purpose of production records, maintenance scheduling, or engineering records.

Transducers

Transducers are used to transmit electrical properties to remote devices, while maintaining a high accuracy when the cabling distance or resistance may be high. The standard output is 4 - 20 mA DC. Current transducers require (1) CT; voltage transducers require (1) PT; watts transducers require (2) CTs and (2) PTs.

Test Blocks

Current and potential test blocks provide a plug-in feature for portable meters, to obtain readings or records without shutting down the machine.

Watt-Hour Meter

Several Power Multifunction Meters are available such as the GE-Multilin PQM and the GE Multilin EPM series.

GE Limitamp® Medium Voltage Motor Control Components



Components

Typical push buttons, selector switches and control wiring used in standard Limitamp appear below, and the following pages detail a range of typical components.

Typical push buttons

| Function | Application | Device used |
|----------------------|--|--|
| Start-Stop | FVNR starters with 3-wire control | CR104P momentary type |
| Stop | Starters with 3-wire control Starters with 2-, 3-wire control | CR104P momentary type CR104P maintained type Options: Mushroom head Provisions for locking open |
| Forward-Reverse-Stop | FVR starters | CR104P momentary type |
| Fast-Slow-Stop | 2-speed starters | CR104P momentary type |

Typical selector switches

| Function | Application | Device used |
|--------------------|--|------------------------|
| On-Off | Permissive start with 2-, 3-wire control | CR104P maintained type |
| Hand-Off-Auto | Auto or manual start with 2-wire control | CR104P maintained type |
| Fast-Slow-Off-Auto | 2-speed starters | CR104P momentary type |

Control wiring details

| Item | Standard | Option |
|------------------------|--------------------------------|--|
| Control wiring type | MTW, thermoplastic, 600V, 90°C | SIS (vulkene) |
| Control wire size | AWG #14 | AWG #12 |
| Control wire terminals | Stripped wire | Insulated ring type |
| Wiremarkers | Plastic sleeve type | Heat-shrinkable labels |
| Wire color code | Power-Black | |
| | Control-Red | |
| | Neutral-White | |
| | Ground-Green | |
| Terminal blocks | CR151B, 30A, 600V | EB-25, 50A, 600V, Connectron Type KUX |

GE Limitamp® Medium Voltage Motor Control Components

G Multilin 239 Motor Protection System



Applications

- Complete protection of small to medium sized motors
- Pumps, conveyors, compressors, fans, sawmills, mines

Key Benefits

- Save on installation cost – compact design
- Enhanced protection – incorporates thermal models
- Setting flexibility – multiple setpoint groups
- Simplify testing – built-in simulation features
- Asset Monitoring – temperature monitoring via optional RTD inputs
- Access information – via Modbus RTU™
- Follow technology evolution – flash memory for product field upgrade

Features

Protection and Control

- Thermal Overload (15 selectable curves) – Trip and alarm, immediate current overload alarm
- Phase short circuit
- Mechanical jam
- Thermal memory lockout
- Single-Phasing /Current unbalance
- Ground fault – trip and alarm
- Overtemperature: via thermistor or optional RTD inputs
- Undercurrent
- Breaker Failure
- Trip/alarm/auxiliary/service outputs
- Multi-speed motor protection
- Motor start supervision

Monitoring and Metering

- Status/current/temperature display
- Fault diagnosis
- Trending
- Trip record, last 5
- Process control
- Optional analog output

User Interface

- RS485 serial port
- Keypad
- 40 character illuminated display
- 6 LED indicators
- Includes EnerVista software

GE Limitamp® Medium Voltage Motor Control Components

Multilin 369 Motor Protection System



Applications

- Medium size motors
- “Down Hole” pump applications
- Suitable for applications involving Variable Frequency Drives

Key Benefits

- Unique and advanced protection features – Back-spin detection, advanced thermal model, most advanced thermal model including multiple RTD inputs for stator thermal protection
- Complete asset monitoring – stator, bearing & ambient temperature, optional full metering including demand & energy
- Improve uptime of auxiliary equipment – through I/O monitoring
- Reduce troubleshooting time and maintenance costs – event reports, waveform capture, data logger
- Simplify testing – built-in simulation features
- Multiple communication protocols – Modbus RTU, Profibus, Device Net
- Cost effective access information – through standard RS232 & RS485 serial ports, and optional embedded Ethernet and Profibus Ports
- Multiple communication ports – RS232, RS485, and Fiber Optic and Ethernet
- Follow technology evolution – flash memory for product field upgrade
- Long lasting life – when exposed to chemically corrosive and humid environments with optional conformal coating
- Suitable for hazardous locations – Underwriters Laboratory certification for Class 1 Division 2 applications
- Installation flexibility – remote display and remote RTD option
- Safe and reliable motor re-start on “Down Hole” pump applications – unique back spin detection feature detects flow reversal on a pump motor, enabling timely and safe motor restarting

Features

Protection and Control

- Full metering: A V W var VA PF Hz Wh varh demand
- Fault diagnosis
- Event record
- Statistical information & learned motor data
- Voltage/frequency/power display (M)
- 4 analog outputs (M)
- Oscillography & Data Logger

Monitoring and Metering

- Thermal model biased with RTD and negative sequence current feedback
- Phase short circuit
- Undervoltage, overvoltage
- Underfrequency
- Thermal overload
- Undercurrent for load loss
- Locked rotor / mechanical jam
- Variable lockout time
- Current unbalance
- Ground fault O/C
- Overtemperature 12 RTDs (R)
- Starts/hour, time between starts
- Phase Reversal (M)

User Interface

- Front Panel 10 LEDs, key pad, and backlit LCD display
- RS232, and RS485 ports – up to 19,200 bps
- Optional embedded Ethernet port
- Optional Profibus Protocol via dedicated port
- ModBus™ RTU Protocol
- ModBus™ over TCP/IP
- Optional Device Net Protocol
- Includes EnerVista software

GE Limitamp® Medium Voltage Motor Control Components

Multilin 469 Motor Protection System



Applications

- Protection and management of three phase medium and large horsepower motors and driven equipment, including high inertia, two speed and reduced-voltage start motors.

Key Benefits

- Unique protection features – Comprehensive motor protection plus voltage dependant overload curves, torque metering and protection, broken rotor bar protection
- Most advanced thermal model – Including multiple RTD inputs for stator thermal protection
- Advanced monitoring functions – vibration, bearing temperature
- Best in class man machine interface (MMI) – Large backlit display with 40 characters to view relay information and settings in direct sunlight, full numerical keypad, and set-point navigation keys.
- Minimize replacement time – Draw-out construction
- Complete asset monitoring – Temperature, Analog I/O, full metering including demand & energy
- Improve uptime of auxiliary equipment – Through I/O monitoring
- Reduce troubleshooting time and maintenance costs – Event reports, waveform capture, data logger
- Simplify testing – Built in simulation features
- Cost effective Access to information – Via Modbus RTU protocol, through standard RS232 & RS485 serial ports, and optional Modbus RTU over TCP/IP through embedded Ethernet Port to connect to 10MB Ethernet local or wide area networks.
- Follow technology evolution – Flash memory for product field upgrade
- Long lasting life when exposed to chemically corrosive and humid environments with optional conformal coating

Features

Protection and Control

- Thermal model biased with RTD and negative sequence current feedback
- Start supervision and inhibit
- Mechanical jam
- Voltage compensated acceleration
- Undervoltage, overvoltage
- Underfrequency
- Stator differential protection
- Thermal overload
- Overtemperature protection
- Phase and ground overcurrent
- Current unbalance
- Power elements
- Torque protection
- Dual overload curves for 2 speed motors
- Reduced voltage starting control

Monitoring and Metering

- A V W var VA PF Hz Wh varh demand
- Torque, temperature
- Event recorder
- Oscillography & Data Logger (trending)
- Statistical information & learned motor data
- Motor starting reports

User Interface

- Front Panel LEDs, full key pad, and backlit LCD display
- RS232, and RS485 ports – up to 19,200 bps
- Optional Embedded 10BaseT, 10Mbps Ethernet port
- ModBus™ RTU Protocol
- ModBus™ over TCP/IP
- Optional Device Net Protocol
- Includes EnerVista software

Inputs and Outputs

- 12 RTDs, programmable
- 5 pre-defined & 4 assignable digital inputs
- 6 output relays
- 4 analog inputs
- 4 programmable analog outputs

GE Limitamp® Medium Voltage Motor Control Components

Multilin 735/737 Feeder Protection System



Applications

- Primary circuit protection on distribution networks at any voltage level
- Backup protection of busses, transformers and power lines

Key Benefits

- Minimize replacement time – draw-out construction
- Simplify testing – built-in simulation features
- Access information - via Modbus RTU

Features

Protection and Control

- 3 phase time overcurrent
- Ground time overcurrent
- 5 curve shapes
- 4 curve shift multipliers per curve
- 10 time multipliers per curve
- ANSI, IAC, or IEC/BS142 curves
- Phase instantaneous overcurrent
- Ground instantaneous overcurrent
- Pickup level for each overcurrent
- Outputs: trip, aux trip, service
- Aux trip: 86 lockout, ground trip
- SR737 has 8 additional output relays

Monitoring and Metering

- Trip record of last 5 trips
- Pre-trip data includes currents
- True RMS sensing

User Interface

- 8 LED trip indicators
- 4 LED status indicators
- Current bar graph, % of CT
- RS485 or RS422 communications
- ModBus™ RTU protocol
- Baud rate up to 19,200 bps

GE Limitamp® Medium Voltage Motor Control Components

G Multilin 750/760 Feeder Protection System



Applications

- Management and primary protection of distribution feeders
- Management and backup protection of busses, transformers and power lines
- Reliable distributed generation interconnection protection system

Key Benefits

- Unique built-in control features – comprehensive feeder protection plus automatic Transfer Scheme, Under Voltage and Under Frequency auto-restore
- Best in class man machine interface (MMI) – large backlit display with 40 characters to view relay information and settings in direct sunlight, full numerical keypad, and set-point navigation keys.
- Accurate metering under sever system disturbances – tracks power system frequency and adjusts sampling rate accordingly
- Improve uptime of auxiliary equipment – through I/O monitoring
- Reduce troubleshooting time and maintenance costs – IRIGB time synchronization, event reports, waveform capture, data logger
- Minimize replacement time – draw-out construction
- Simplify testing – built-in simulation features
- Cost Effective Access information – via Modbus RTU and DNP 3.0 Level 2 protocols, through standard RS232, RS485 & RS422 serial ports, and optional Modbus RTU over TCP/IP through embedded Ethernet Port to connect to 10MB Ethernet local or wide area networks
- Complete asset monitoring – analog I/O full metering including demand & energy
- Follow technology evolution – flash memory for product field upgrade
- Long lasting life – when exposed to chemically corrosive and humid environments with optional conformal coating

Features

Protection and Control

- Complete time, instantaneous & directional phase, neutral, ground and negative sequence overcurrent
- Time, instantaneous & directional sensitive ground overcurrent
- Voltage restraint overcurrent
- Bus phase and line auxiliary undervoltage
- Bus phase overvoltage
- Neutral overvoltage
- Negative sequence voltage
- Undervoltage automatic restoration
- Bus underfrequency
- Underfrequency automatic restoration
- Automatic bus transfer
- Breaker failure
- Manual close control
- Cold load pickup control
- Power factor control
- 4 shot recloser
- 4 setting groups
- Syncrocheck - V, f, Hz, & dead-source
- 20 Programmable logic inputs

Monitoring and Metering

- Fault locator, record of last 10
- Breaker operation & trip failure
- VT Failure
- Power factor – two independent stages
- Analog input – level and rate
- Total breaker arcing current
- Event recorder
- Oscillography and Data Logger
- Metering: V I Hz W var VA PF
- Demand: Ia , Ib , Ic , MW, Mvar, MVA

User Interface

- Front Panel LEDs, full key pad, and backlit LCD display
- RS232, RS485 and RS422 ports - up to 19,200 bps
- Ethernet port – 10Mbps
- Multiple protocols – ModBus™ RTU, ModBus™ RTU TCP/IP, DNP 3.0 Level 2
- Includes EnerVista software

GE Limitamp® Medium Voltage Motor Control Components

Multilin LM10 Motor Protection System



Applications

- Ideally suited for motor control center applications
- Low voltage motors up to 500 hp
- Motor types: full voltage reversing and non-reversing; reversing; two speed one and two windings; custom motor types

Key Benefits

- Small footprint and compact design – fits into standard Motor Control Center “buckets”
- Easy to use – preconfigured motor setting
- Modular design – pick and choose the desired components
- PLC, SCADA, and DCS Interface – DeviceNet open protocol standard
- Easy installation – matched CTs; panel or chassis mount
- Programmed through EnerVista Launchpad

Features

Protection and Control

- Overcurrent, current unbalance, ground fault, overvoltage/undervoltage
- Jam, stall, load loss
- Power loss restart
- Two speed motor protection
- 6 digital inputs, 4 relay outputs

Monitoring and Metering

- Phase current, ground current, voltage, kW, power factor, average current, current unbalance
- Trip history and maintenance information – last 10 fault history report
- Elapsed motor hours

User Interface

- DeviceNet open protocol
- RS232 direct PC connection
- Optional programmable display unit
- Spanish language option
- Passcode protection

GE Limitamp® Medium Voltage Motor Control Components

G PQM II Power Quality Metering System



Applications

- Metering of distribution feeders, transformers, generators, capacitor banks and motors
- Medium and low voltage systems
- Commercial, industrial, utility
- Flexible control for demand load shedding, power factor, etc.

Key Benefits

- Power quality metering with waveform capture and historical data logging
- Easy to program and use with keypad and large illuminated 40 character display
- Multiple communication port for integration with DCS and SCADA systems
- Supports DNP 3.0 and Modbus protocols
- Digital and analog I/Os for control and alarms
- Voltage disturbance recording capability for electrical sag and swell events.

Features

Protection and Control

- A V W var VA varh Wh PF Hz unbalance
- A W var VA demand
- Load shedding
- Power factor control
- Pulse input totalizing

User Interfaces

- Front RS232 serial port (1,200 to 19,200 bps)
- Two rear RS485 serial ports with ModBus and DNP 3.0 protocol
- Ethernet connectivity provided by MultiNet
- EnerVista software is provided for setup and monitoring functions
- External dial-in modem capabilities

Monitoring and Metering

- Ia Ib Ic In
- Va Vb Vc Vab Vbc Vca
- V I unbalance
- True PF crest and K factor
- Hz W var VA
- Wh varh VAh W cost
- Demand: A W var VA
- Harmonic analysis through 63rd with THD and TIF
- Event recorder – 150 events
- Waveform capture
- Data logger – 98,000 events
- Voltage Disturbance Recorder (VDR) -500 events

GE Limitamp® Medium Voltage Motor Control Components

Multilin SPM Synchronous Motor Protection System



Applications

- Starting, synchronizing and protection of collector-ring or brushless-type synchronous motors

Key Benefits

- Complete asset monitoring – field winding temperature and statistical data
- Improve uptime of auxiliary equipment – through I/O monitoring
- Access to information – RS485 Communications port and Modbus RTU Protocol

Features

Protection and Control

- Field application
- DC field current loss, exciter current loss, DC field voltage check
- PF regulation, reluctance torque synchronizing
- Protects motor during start up and in the event of asynchronous operation
- Squirrel cage winding overheating protection
- Automatic phase rotation correction
- Auto-loading and incomplete sequence
- Regulator tuning mode
- True RMS metering with DFT filtering
- Optional power factor regulator with five adjustable set points
- Power factor & pull out protection (optional)
- Speed dependent squirrel cage overload protection
- Frequent start protection

Monitoring and Metering

- Motor power factor
- DC amps and voltage
- AC current
- Exciter field resistance
- Motor run time, number and type of trips
- Number and type of trips

User Interface

- RS485 serial port

GE Limitamp® Medium Voltage Motor Control Components

Universal Relay™ Family



Applications

- All power generation, transmission, distribution, motor protection applications
- Generator, Differential, Phase, Transformer, Bus, Feeder, Breaker and Motor protection, monitoring, metering and control
- Utility substation and industrial plant automation
- Digital Fault Recorder and Sequence of Event
- Predictive maintenance through data analysis and trending

Key Benefits

- Application flexibility – multiple I/O options, programmable logic (FlexLogic™), modularity, customize to specific requirements
- Fewer external devices required – multifunction device that integrates protection and control functions, programmable pushbuttons and status LEDs, and communication interfaces
- Modular construction – common hardware, reduced stock of spare parts, plug & play modules for maintenance cost savings and simplification
- Common platform – reduced training time and drafting costs
- Use high speed communications to reduce wiring and installation costs – exchange inputs and outputs between relays to achieve relay-to-relay interaction
- Cost effective and flexible access to information – multiple communication options and protocols
- Reduce system event analyzing time and cost – sequence of event reports, oscillography, datalogging, IRIG-B time synchronization
- Long lasting life – when exposed to chemically corrosive and humid environments with optional conformal coating
- Enhanced CT/VT Diagnostics – enhanced CT/VT module diagnostics verifying the integrity of the analog signals using an advanced algorithm ensuring reliable performance of the relay

Features

Protection and Control

- Extensive protection and control capabilities
- Up to 96 digital input and 64 digital outputs
- Solid state output modules for fast tripping
- Transducer I/Os (RTD, dcmA)
- Dual power supply (option)

Communications

- Networking options – Ethernet-fiber (optional redundancy), RS422, RS485, G.703, C37.94
- Multiple protocols – IEC 61850, DNP 3.0 Level 2, Modbus RTU, Modbus TCP/IP, IEC 60870-5-104, Ethernet Global Data (EGD)
- Direct I/O – exchange of binary data between URs

Monitoring and Metering

- Synchrophasors
- Oscillography – up to 64 records
- Event Recorder – 1024 time tagged events, with 0.5ms scan of digital inputs
- DataLogger – up to 16 channels with user selectable sampling rate
- Fault locator and user programmable fault reports
- Breaker condition monitoring including breaker arcing current (I2t)
- Metering – current, voltage, power, power factor, frequency, current harmonics

User Interface and Programming

- Front panel display and keypad for local access; RS232 port for local PC access
- User programmable local display, LEDs and pushbuttons
- Customize protection and control functions with FlexLogic™, FlexCurves™, and FlexElements™
- Includes EnerVista LaunchPad – Simple relay setup and programming
- Multi-language – French, Chinese, Russian option

GE Limitamp® Medium Voltage Motor Control Components

F60 Feeder Protection System



Applications

- Primary protection for distribution feeders
- Stand-alone or component in automated substation control system
- Interlocking scheme on distribution level by means of Remote I/O features
- Throw over schemes (bus transfer scheme)
- Load shedding scheme based on frequency elements

Key Benefits

- Unparalleled security/safety – downed conductor detection
- Reliable Distributed Generation interconnection protection
- Dependable and secure – performance backed up by many years of field experience
- Cost effective and flexible access to information – multiple communication options and protocols
- Breaker monitoring – monitor breaker conditioning through analog I/O, rich metering, breaking arcing current, and trip counters
- Use high speed communications to reduce wiring and installation costs – exchange inputs and outputs between relays to achieve relay-to-relay interaction
- Reduce installation space requirements through compact design – multifunction device that integrates protection and control functions, programmable pushbuttons and status LEDs, and communication interfaces
- Maintenance cost savings and simplification – modular construction, common hardware, reduced stock of spare parts, plug & play modules
- Application flexibility – multiple I/O options, programmable logic (FlexLogic™), modularity, customize to specific requirements
- Reduce system event analyzing time and cost – sequence of event reports, oscillography, datalogging, IRIG-B time synchronization
- Embedded IEC 61850 Protocol – no external protocol converter required

Features

Protection and Control

- Downed conductor detection – high impedance faults
- Phase, neutral, ground or sensitive ground and negative sequence IOCs and TOCs with directional control
- Sensitive directional power
- Breaker failure
- Breaker control
- Four-shot autorecloser with synchronism check
- Up to 80 digital input and 56 digital outputs
- Transducer I/Os (RTD, dc mA)
- Wattmetric zero-sequence directional function

Communications

- Networking options – Ethernet-fiber (optional redundancy), RS485, RS422, G.703, C37.94
- Multiple protocols – IEC 61850, DNP 3.0 Level 2, Modbus RTU, Modbus TCP/IP, IEC 60870-5-104, Ethernet Global Data (EGD)
- Direct exchange of Inputs/Outputs – exchange of binary data between URs

Monitoring and Metering

- Metering – current, voltage, power, energy, frequency, voltage and current harmonics, demand (current, power)
- Oscillography – 64 samples/cycle, up to 64 records
- Event Recorder – 1024 time tagged events, with 0.5ms scan of digital inputs
- DataLogger – up to 16 channels with user selectable sampling rate
- Fault Locator

User Interfaces and Programming

- Front panel display and keypad for local direct access, with an RS232 port for local PC access
- User programmable local display, LEDs and pushbuttons
- Customize protection and control functions with FlexLogic™ FlexCurves™, and FlexElements™
- Includes EnerVista LaunchPad - Simple relay setup and programming
- Multi-language support – French, Chinese, Russian option
- Order must include complete catalog number of required device

GE Limitamp® Medium Voltage Motor Control Components

M60 Motor Protection System



Applications

- Any size of AC induction or synchronous motor
- Stand-alone or component in automated control system

Key Benefits

- Best in class human machine interface (HMI) – view relay information and settings, full numerical keypad, and setpoint navigation keys.
- Unique protection features – comprehensive motor protection with voltage dependant overload curves
- Advanced thermal model – including multiple RTD inputs for stator thermal protection
- Integrated monitoring functions – vibration, bearing temperature, analog I/O, full metering
- Cost effective and flexible access to information – multiple communication options and protocols
- Use high speed communications to reduce wiring and installation costs – exchange inputs and outputs between relays to achieve relay-to-relay interaction
- Reduce installation space requirements through compact design – multifunction device that integrates protection and control functions, programmable pushbuttons and status LEDs, and communication interfaces
- Maintenance cost savings and simplification – modular construction, common hardware, reduced stock of spare parts, plug & play modules
- Application flexibility – multiple I/O options, programmable logic (FlexLogic™), modularity, customize to specific requirements
- Reduce system event analyzing time and cost – Sequence of event reports, oscillography, datalogging, IRIG-B time synchronization
- Embedded IEC 61850 Protocol - no external protocol converter required

Features

Protection and Control

- Phase and neutral directional overcurrent
- Thermal overload, overvoltage, undervoltage and reverse phase sequence
- Stator-restrained differential
- VT fuse failure
- Breaker failure
- Stator differential
- Sensitive directional power – reverse and low forward power
- Current unbalance
- Configurable TOC curves with FlexCurves™
- Thermal model RTD bias function
- Up to 80 digital input and 56 digital outputs
- Transducer I/Os (RTD, dcmA)

Communications

- Networking options – Ethernet-fiber (optional redundancy), RS485, RS422, G.703, C37.94
- Multiple protocols – IEC 61850, DNP 3.0 Level 2, Modbus RTU, Modbus TCP/IP, IEC 60870-5-104, Ethernet Global Data (EGD)
- Direct I/O – exchange of binary data between URs

Monitoring and Metering

- Metering – current, voltage, power, energy, frequency
- Transducer I/O to monitor condition of breaker and motor auxiliary systems
- Oscillography – 64 samples/cycle, up to 64 records
- Event Recorder – 1024 time tagged events, with 0.5ms scan of digital inputs
- DataLogger – up to 16 channels with user selectable sampling rate
- User programmable fault reports

User Interface and Programming

- Front panel display and keypad for local direct access, with an RS232 port for local PC access
- User programmable local display, LEDs and pushbuttons
- Customize protection and control functions with FlexLogic™, FlexCurves™, and FlexElements™
- Includes EnerVista LaunchPad – simple relay setup and programming
- Multi-language support – French, Chinese, Russian options

GE Limitamp® Medium Voltage Motor Control Components

Model GFM Ground Fault System

UL-listed File number E110395



Description

These Class 1 model GFM ground fault protection systems are designed to minimize damage or loss to equipment caused by destructive arcing ground faults. This GFM system is designed for all polyphase applications and is ideally suited for motor control, motor control centers and high-voltage starters. Systems can be wye or delta, grounded or resistance grounded. When the ground fault current exceeds a preselected condition (current only, or current and time settings), the relay trips. The relay contacts can be connected in the control circuit of a motor starter, to the shunt trip of a circuit breaker or similar disconnecting or alarm devices. The system has an inverse time characteristic to prevent nuisance tripping. The relay tripping current value is field adjustable over the trip current range of the sensor. The adjustable trip time delay relay, when specified, is field settable up to 36 cycles.

Features

- Main contact rated 30 amperes, 277 volts AC
- Auxiliary contacts rated 10 amperes continuous, 23 amperes inrush, 120 volts AC
- Self powered
- Temperature range: -30° C to 75° C
- Positive "ON" (green) and "OFF" (red) condition indication, manual reset
- Instantaneous only (GFM-353) standard
- Optional time delay from instantaneous to 36 cycles (GFM-363)

Sensors

| Model number | Trip current | Window size |
|--------------|--------------|-------------|
| GFM 250 | 3.5 to 11 | 2.5" |
| GFM 462 | 4 to 12 | 4.62" |

GE Limitamp® Medium Voltage Motor Control Components

G

LPVRB-120 Phase Voltage Relay



Description

The Model LPVRB-120 is designed to protect 3-phase loads from damaging power conditions. Its wide operating range combined with UL and CE compliance enables quick access to domestic and global markets. A unique microcontroller-based voltage and phase sensing circuit constantly monitors the three phase voltages to detect harmful power line conditions. When a harmful condition is detected, the LPVRB-120's output relay is deactivated after a specified trip delay. The output relay reactivates after power line conditions return to an acceptable level for a specified amount of time (Restart Delay) or after a manual reset. The trip and restart delays prevent nuisance tripping due to rapidly fluctuating power line conditions. An adjustment is provided to set the nominal line voltage from 95-120 VAC. Other adjustments include a 1-30 second trip delay, a 1-500 second restart delay, and a 2-8% voltage unbalance trip point adjustment. Two LEDs indicate the status of the Model LPVRB-120; Run Light, Under Voltage, Over Voltage, Phasing Fault/ Reverse Phase, and Manual Reset. The LPVRB-120 ships with a jumper installed for automatic restart. A connector with two 12" wires is included for manual reset switch.

Key Benefits

Protects 3-Phase motors from:

- Loss of any Phase
- Low Voltage
- High Voltage
- Voltage Unbalance
- Phase Reversal
- Rapid Cycling

Features

- Four adjustment pots provide versatility for all kinds of applications
- Range from 95-120 VAC 50/60 Hz provides the versatility needed to handle global applications
- Diagnostic LEDs indicate trip status and provide simple troubleshooting
- Microcontroller based circuitry provides better accuracy and higher reliability than analog designs
- Transient protected to meet IEEE and IEC standards and operate under tough conditions
- Will detect single phase condition regardless of regenerated voltages
- Compact design
- UL and cUL listed
- CE compliant
- Finger safe terminals
- 5 year warranty
- Made in USA
- Standard surface or DIN rail mount
- Standard 1-500 sec. variable restart delay
- Standard 2-8% variable voltage unbalance
- Standard 1-30 sec. variable trip delay
- One 10 amp general purpose Form C relay
- Optional manual reset

GE Limitamp® Medium Voltage Motor Control Components

FT Test Switch



Application

The ITI Type Test Switches and Test Plugs provide a safe, simple, fast and reliable method to isolate and service installed equipment.

Key Benefits

The FT Switches and FT Test Plugs have all the features necessary for applications involving the measurement of individual currents and voltages to facilitate testing of substation instrumentation and protection devices from the front of the panel. The make-before-break current short circuit feature also allows test personnel to test quickly and safely.

The FT Switch is built with a maximum of ten individual poles or switch units. The switches can be assembled in a variety of different arrangements to match customer requirements. ITI FT Test plugs are used in conjunction with the FT Switches to enable easy measurement, calibration, verification or maintenance of relay, meters and instruments.

Voltage measurements can also be made directly on the FT Switch without disturbing existing connections. There is a test clip provision located on the top of each pole that allows connection with standard spring clip test leads.

With the cover in place, a meter type seal can be placed through either of the cover studs of the FT Switch to prevent unauthorized access to the switch. As an additional feature, a clear cover is available that can be installed and locked with the switchblades in the open or closed position.

GE Limitamp® Medium Voltage Motor Control Components



CR120B Machine Tool and Industrial Relays

Description

The CR120B and CR120BL Series A multi-circuit industrial relays are designed to meet most panel application requirements. They are available as standard, latched or time-delay relays.

All forms of the relay mount on the same base and in the same small panel-mounting area. Relays may be arranged in any configuration or modified on a panel without altering the mounting area.

Features

- Unique bifurcated contacts assure positive make at all voltages and give excellent fidelity, even in harsh environments.
- Transparent Lexan® contact cartridges allow inspection of contacts
- Convertible contacts allow conversion from normally open to normally closed or vice versa – just change the terminal screws and invert the contact module
- Coil can be changed quickly and without removing any screws

Latch Attachment

The latch attachment mounts on any standard CR120B relay in the same manner as a deck adder.

Coil data

| Coil | Inrush VA | Sealed VA | Sealed watts |
|-----------------|-----------|-----------|--------------|
| AC relay coil | 120 | 15 | 7 |
| AC unlatch coil | 31 | 15 | 9.2 |
| DC relay coil | 235 | 2.8 | 2.8 |

Coil data

| | Volts |
|-------|-------------------|
| 60 Hz | 115-120, 230, 460 |
| DC | 24, 48, 125 |

Contact ratings

| Type of contacts | Max. AC voltage | Max. continuous rating amperes | Maximum AC volt-ampere rating | | Maximum AC rating amperes | | Maximum DC rating amperes | | Maximum DC volt-ampere rating 300V or less |
|------------------|-----------------|--------------------------------|-------------------------------|-------|---------------------------|-------|---------------------------|------|---|
| | | | Make | Break | Make | Break | 125V | 250V | |
| Inst.1 | 600 | 10 | 7200 | 720 | 60 | 6 | 1.1 | 0.55 | 138 |
| Delay | 600 | 5 | 3600 | 360 | 30 | 3 | 0.5 | — | — |

1 Use for CR120B contact rating.

GE Limitamp® Medium Voltage Motor Control Components

CR104P Pilot Devices



Description

Nameplates with chrome-plated octagonal rings project an attractive, quality appearance. Positive-feel selector switches give a quality touch in all illuminated, solid-color, spring-return and maintained units.

Standard and illuminated push buttons and selector switches are available with key or conventional operation. The CR104P push button line also includes press-to-test and standard indicating lights, mushroom-head, joystick, push-pull and push-push operators.

Application

These pilot devices are specially adapted to machine-tool service or any application where oil or coolant is present. The convenient one-hole mounting makes this line suitable for general purpose use in equipment of all kinds where panel mounting is possible. This line is ideal for applications where oil tightness, watertightness and long life are essential.

All units are suitable for use in Type 1, 3, 3R, 4, 12 and 13 environments when mounted in enclosures rated for those same applications. (CR104PTP units suitable for Type 1, 12 and 13 only.)

Features

- Ease of assembly – One-screw contact block mounting. Octagonal ring provides ease in front panel mounting and enclosure applications.
- Greater torque – Due to the eight-sided ring design, greater torque can be developed during assembly and installation to provide oil tightness.
- Stocking inventories reduced – Forms may be furnished as complete units or as components, allowing building-block construction from a minimum of stock.
- Color convertible – Colored knobs and caps are available in kit form for easy field conversion.

| Type | Standard | Push-to-test | Bulb | Color |
|------------------------------------|----------|--------------|--------------|-------|
| Full voltage (120 Volts AC) | X | X | #120PSB | Red |
| | | | | Green |
| | | | | Amber |
| Transformer (6 Volts AC Secondary) | X | X | #755 | Blue |
| | | | | White |
| | | | | Clear |
| | | | | Red |
| Neon | X | N/A | Neon | White |
| | | | | Amber |
| | | | | Clear |
| | | | | Red |
| LED (Transformer type only) | X | X | LED (6 volt) | Green |
| | | | | Blue |
| | | | | Amber |
| | | | | Red |

Contact Ratings

AC ratings, NEMA A600 heavy pilot duty

| Maximum AC | Continuous current amperes | AC voltamperes 50/60 Hz ¹ | |
|------------|----------------------------|--------------------------------------|-------|
| | | Make | Break |
| 600 | 10 | 7200 | 720 |

¹ Maximum make and break currents are 60 and 6 amperes, respectively, for voltages of 120 and below.

DC ratings, NEMA P600

| Maximum make or break amperes | | |
|-------------------------------|-----------|-----------|
| 125 volts | 250 volts | 600 volts |
| 1.1 | 0.55 | 0.2 |

CR104P Pilot Lights

Pilot lights match appearance of switches above. Standard applications use full-voltage or transformer-type lights. Optional nameplates match those used with switches; neon lights are available (with limited lens colors).

Typical pilot lights

| Function | Device used | |
|------------------|--|-----------------------|
| Full voltage | CR104P with 120-volt, 10,000-hour lamp | |
| Transformer | CR104P with 6-volt, 20,000-hour lamp | |
| Push-to-test | CR104P, full-voltage or transformer-type | |
| Colors available | Red | On, Fast, Forward, Up |
| | Amber | Down, Reverse, Slow |
| | Green | Stopped, Ready |

GE Limitamp® Medium Voltage Motor Control Components

G C2000 RL4 Control Relays G3



Control Relay catalog numbers are shown in the shaded area in the **Control Relay Selection and Data** table. To complete the catalog number, replace the asterisk (*) with the appropriate digit from the shaded area in the **Coil Selection** table. Additional coil information is shown in the **Coil Data** table.

Control Relay Selection and Data

| | | Contact Arrangement | | | |
|-------------------|----------------------------|--|------------|------------|------------|
| | | 4NO-0NC | 3NO-1NC | 2NO-2NC | 0NO-4NC |
| AC Control Relays | | RL4RA040T* | RL4RA031T* | RL4RA022T* | RL4RA004T* |
| DC Control Relays | | RL4RD040T* | RL4RD031T* | RL4RD022T* | RL4RD004T* |
| Aux. Contacts | Maximum Aux. Contacts | 4 | 4 | 4 | 4 |
| | Maximum Aux. Configuration | 4 Front-Mount or 1 Side-Mount on each side | | | |
| Contact Rating | | A600 P600 | | | |

| Contact Rating | A600 | P600 |
|----------------------------|------------|---------|
| Continuous Thermal Current | 10A | 5A |
| Max. VA/Amps Making | 7200VA/60A | 138VA |
| Max. VA/Amps Breaking | 720VA/6A | 138VA |
| Max. Operating Voltage | 600 VAC | 600 VDC |

Note: For DC ratings at 300 Volts or less, the make and break ratings shall be obtained by dividing the voltampere rating by the application voltage but shall not exceed the continuous carrying current.

The DC rating shown in the above table shall not be exceeded when applied to control circuit devices.



RL4RA040T* RL4RA031T* RL4RA022T* RL4RA004T*
 RL4RD040T* RL4RD031T* RL4RD022T* RL4RD004T*

Coil Selection

| AC Voltage | | DC Voltage | Coil Suffix |
|------------|---------|------------|-------------|
| 60 Hz | 50 Hz | | |
| 24 | 24 | — | 1 |
| — | — | 12 | B |
| — | — | 24 | D |
| 48 | 42 | — | F |
| — | — | 48 | G |
| 120 | 110 | — | J |
| — | — | 125 | K |
| 208 | — | — | L |
| 277 | 220/230 | — | N |
| 240 | — | — | S |
| — | — | 250 | T |
| 480 | 380/400 | — | U |
| — | 415 | — | W |
| 600 | 500 | — | Y |

Coil Data

| | AC Voltage | DC Voltage |
|------------------------------------|------------|------------|
| Burden | | |
| Inrush | 45 VA | 5.5 W |
| Holding | 6 VA | 5.5 W |
| Pick-up Voltage (% Of Coil Volts) | 85-110 | 80-110 |
| Drop-Out Voltage (% Of Coil Volts) | 40-55 | 20-40 |
| Switching Delay (ms) | | |
| Switching Delay On | | |
| Coil Voltage at +10% to-20% | 6-25 | 35-65 |
| Coil Voltage at Rated Value | 8-20 | 40-45 |
| Switching Delay Off | | |
| Coil Voltage at +10% to-20% | 6-13 | 30-60 |
| Coil Voltage at Rated Value | 6-13 | 30-60 |
| Maximum Operations per Hour | | |
| No Load | 9000 | 3600 |
| Rated Load | 1200 | 1200 |

GE Limitamp® Medium Voltage Motor Control Components

Contactor Economizing Module

Description

The Contactor Economizing Module (CEM) is a solid state encapsulated module that is designed to apply the proper voltage to pick-up and seal close GE CR193B, C, D and E medium voltage vacuum contactors. The CEM performs the same function as the older CTM, including the anti-pump function, except it utilizes phase control SCRs to control output voltage instead of a series capacitor.

The CEM is powered by 115 VAC nominal AC power, 50/60 Hz. Incoming power is to be applied to terminals "1" and "2" of the module. Use a separate contact in series with the AC power to switch the CEM (and contactor) on and off.

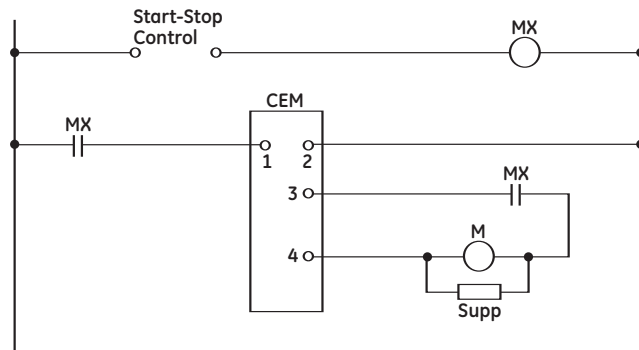

The CEM DC output terminals to the contactor coil are "3" (-) and "4" (+). It is customary to place an additional series switching contact directly in the coil circuit to minimize the contactor drop-out time. When the DC coil current is interrupted by this contact, the L/R coil time constant is greatly reduced, shortening the drop out time of the contactor to about 50 milliseconds. If this additional switching contact is omitted, the contactor drop out time will be as much as 500 milliseconds. It is also recommended to place RC suppression (SUPP, 0.1 MFD capacitor in series with 100 Ω resistor), cat. no. 302A3847P1, directly across the contactor coil terminals to reduce inductive "kick-back" voltages.

The CEM functions as follows: For one second after application of 115 VAC to terminals "1" and "2", the output voltage between terminals "3" and "4" is in the range of 100 to 110 VDC when the contactor coil is connected. After one second, the voltage is reduced to 20 to 25 VDC for as long as AC power is applied. When AC power is removed, the DC voltage is removed from the contactor coil and the contactor drops out. The cycle is repeated when AC power is reapplied to the CEM. The purpose is to provide the high coil voltage for a long enough period of time necessary to pick up the contactor (1 second) and then transition to a much lower coil voltage to economically maintain the contactor in a sealed closed condition. This reduction in voltage reduces power consumption and greatly reduces temperature rises in the coil.

GE Limitamp® Medium Voltage Motor Control Components

Adjustable Power-Dip Ride-Through



Description

The power-dip ride-through feature is available for critical process applications where forced motor shutdowns are very disruptive and where power system outages are expected to last less than 20 cycles (333 milliseconds).

If a loss of power occurs while the main contactor M is closed (see diagram) relays UV and MX transition to the de-energized state. The normally-closed contact of UV and the normally-open contact of MX in the coil circuit overlap as they change state, thus avoiding an interruption of the decaying coil current. The power to the main contactor coil is removed but stored energy in the magnetic armature keeps the contactor closed. After 20 cycles of outage (or less, depending on MX relay time setting), MX (T.O.) contacts time open and interrupt the decaying DC coil circuit, causing the contactor to immediately open. The contactor will now remain open until manually restarted by the START pushbutton.

If power is restored before the MX (T.O.) contacts time open, the MX relay recloses to re-energize the main contactor coil, maintaining the contactor tips closed throughout the outage interval. Use 125VDC MX coil for 115-120 VAC control power (60hz); or 110 VDC MX coil for 105-110 VAC control power (50hz).

For a normal STOP operation (using the STOP pushbutton), it is desired to bypass delayed contactor drop out. When the stop pushbutton is pressed, relay MX normally-open contacts open to remove power to both the AC and DC sides of the Contactor Economizing Module (CEM). (The CEM provides, among other things, the rectification of AC voltage to DC for powering the main contactor coil).

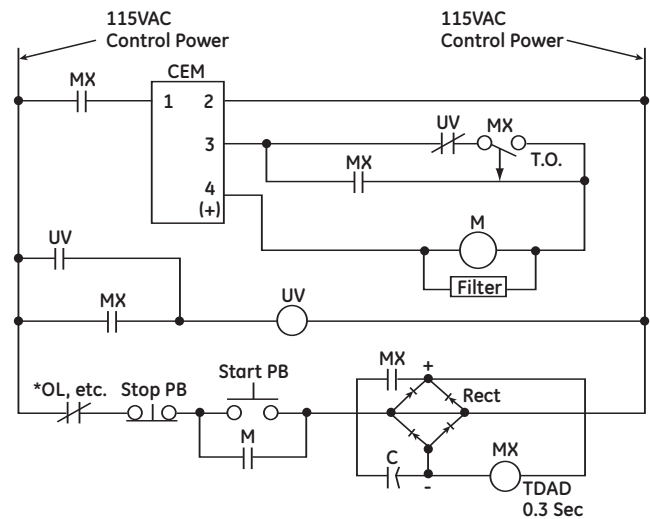

CAUTION: Overload and other permissive interlocks such as Multilin trip contacts must be non-failsafe. That is, they must not open on loss of control voltage.

NOMENCLATURE

- C - 10 MFD CAPACITOR (Cat. NKE#18F232)
- CEM - CONTACTOR ECONOMIZING MODULE
- FILTER - R-C FILTER (Cat. 302A3847P1).
- M - MAIN CONTACTOR (Types CR193 B, C, D&E)
- MX - CONTROL RELAY W/TIMING HEAD
- OL'S - PROTECTIVE RELAY CONTACTS
- PB - PUSHBUTTON
- RECT - RECTIFIER (Cat. 169B7656G2)
- TDAD - TIME DELAY DE-ENERGIZATION
- T.O. - TIME OPENING
- UV - UNDERVOLTAGE RELAY (Cat. RL4RA22TJ)
- Mounting means for 10 MFD capacitor - 129B8150G1

GE Limitamp® Medium Voltage Motor Control Components

TPI, CPI & TSW

Description

Test Power Interlocks (TPI) and Control Power Interlocks (CPI) are standard. The function of the CPI contacts is to disconnect the secondary of the internal control power transformer before the main isolation switch can be operated. This is important because the isolation switch is rated for non-load break duty only, and is tested to switch transformer-magnetizing current only. The TPI contacts function to transfer control power from the internal control power transformer (when the isolation switch handle is in the ON position), to external test power (when the switch handle is in the OFF position) and to prevent backfeeding the control power transformer from test power.

TSW is a selector switch that is provided as standard to switch from internal control power to remote test power source. It is provided as a back-up to the TPI contacts to provide an additional layer of protection against accidental backfeed of the control power from test power.

CPI contacts are linked to the Handle Latch Release (pusher) bar on the external handle assembly. In the released state (pusher not depressed) the CPI contacts are in the CLOSED state and the ON-OFF isolation switch handle is locked in either the ON or OFF position. If the main contactor is open, the pusher bar may be depressed. Once the pusher bar is depressed, the CPI contacts change to the OPEN state and the external ON-OFF handle, that operates the controller isolation switch, is released.

The TPI contacts are linked to the ON-OFF handle position such that the TPI contacts change state as the handle position is changed.

GE Limitamp® Medium Voltage Motor Control Components

Multilin EB-27 Terminal Blocks



Application

EB-27 terminal blocks are used where any permanent or temporary wiring connections are required, especially if many wires are involved.

Description

The EB-27 terminal blocks are molded one piece design available in 4, 6, and 12 points. They are furnished with washer-less head binding screws (#10-32) for circuit wire connections. The blocks are supplied with a black marking strip with white numbers on one side, and white unmarked on the reverse side for circuit identification. To mount the terminal block, drill for a No. 10 screw. The board will accommodate No. 18 to No. 10 inclusive wire sizes.

The minimum spacing between the barrier separation is 11/32 inches. The distance between adjacent connection screws is 5/8 inches.

GE Limitamp® Medium Voltage Motor Control Components

G

Fixed MV Power Factor Correction Capacitors



Application

Type HWT equipments are suitable for use on indoor or outdoor primary circuits where small amounts of kVAR are required. They may be installed at load centers or directly at the terminals of 2300 and 4000 volt motors. Permissible ambient temperatures are -40° to $+45^{\circ}\text{C}$. Discharge resistors in each capacitor reduce the voltage to 50 volts or less within 5 minutes of de-energization. Type HWT equipments contain less than three gallons of flammable liquid in a single container and therefore do not require installation in a vault to meet the NEC.

Specifications

- Enclosed Indoor Dustproof and Outdoor Weatherproof
- 25-900 kVAR, 60 Hz
- 2400, 4160, 4800 Volts
- 1.0-200 kVAR, 240 Volt
- Line Terminals

Solderless connectors are provided on each phase:

Assembly Connector Size

One unit #10 - #4

Two unit #14 - 1/0

Three unit #6 - 250 kcmil

Fuses

Protection is provided by 50,000 ampere interrupting capacity current limiting fuses. A pop-up button on the fuse gives visual indication of a blown fuse. GE recommends the use of three fuses for the most complete protection against terminal-to-terminal and terminal-to-ground failures on grounded systems. Two fuses are sufficient to provide protection against terminal-to-terminal failures on ungrounded systems.

Blown Fuse Lights

Blown fuse lights provide a positive external indication of an operated fuse. A glowing light makes inspection of capacitors easy, effective, and safe. A 120 VAC source must be supplied externally. When ordered with this option, the HWT assembly is supplied with one light per capacitor.

GE Limitamp® Medium Voltage Motor Control Components



Polymer Station Arresters



Station Class arresters are used in large utility and industrial substations to protect transformers and other substation equipment from lightning and switching surge-generated overvoltages. TRANQUELL® polymer arresters provide both excellent protective characteristics and temporary overvoltage capability.

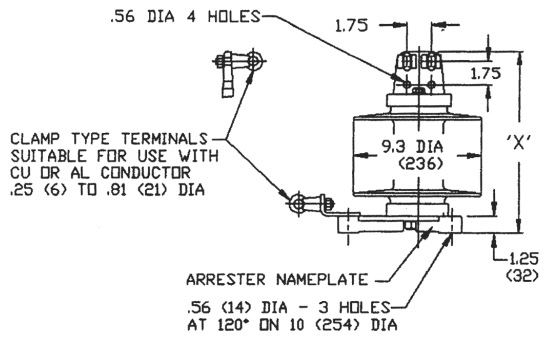

Insulation Characteristics

| Rated Voltage (kV rms) | Creep in. (mm) | Strike in. (mm) | Minimum 1.2 x 50 μs Withstand (kV crest) | Minimum Power Frequency (kV rms) | |
|------------------------|----------------|-----------------|--|----------------------------------|-------------|
| | | | | Wet (10 sec) | Dry (1 min) |
| 3 | 23 (584) | 8.9 (225) | 120 | 57 | 88 |
| 6 | 23 (584) | 8.9 (225) | 120 | 57 | 88 |

Dimensions, Leakage Distances, Mounting Clearance & Weights

| Rated Voltage (kV) | MCOV (kV rms) | "X" Overall Height in. (mm) | | Mounting Clearance | | | Weight lbs. (kg) | |
|--------------------|---------------|-----------------------------|------------------|--|-----------------------------------|-----------------------|------------------|------------------|
| | | NEMA Pad | Eyebolt Terminal | Leakage Distance Terminal to Base in. (mm) | Centerline to Centerline in. (mm) | Center Line to Ground | NEMA Pad | Eyebolt Terminal |
| 3 | 2.55 | 13.7 (348) | 10.2 (259) | 23 (584) | 12.3 (312) | 7.7 (196) | 22 (10.0) | 20.3 (9.2) |
| 6 | 5.10 | 13.7 (348) | 10.2 (259) | 23 (584) | 12.3 (312) | 7.7 (196) | 23 (10.4) | 20.8 (9.4) |

GE Limitamp® Medium Voltage Motor Control Components

G

Protective Capacitors for AC Rotating Machines



Application

Protective capacitors offer surge protection for AC generators, synchronous condensers and large motors.

DIELEKTROL is the GE non-PCB power capacitor dielectric system, developed to provide an environmentally acceptable product with superior performance and reliability. Protective capacitors contain a film dielectric and hermetically sealed bushings, which permit mounting of capacitors in an upright position or on the side. GE surge capacitors protect the winding insulation by reducing the steepness of wave fronts applied to or reflected within the machine windings.

Features and Benefits

- Surge protection for AC Generators, synchronous condensers and large motors
- Time proven GE HAZY film foil dielectric system
- DIELECTROL Non-PCB insulating fluid
- Provides turn-to-turn insulation protection by reducing steepness of wave fronts applied to or reflected within the machine
- Used in combination with Tranquell station arresters for optimum protection
- Protective capacitors contain a film dielectric and hermetically sealed bushings, which permit mounting of capacitors in an upright position or on the side.
- Altitude: 0 to 18,000 feet

GE Limitamp® Medium Voltage Motor Control Components

CR151B One Piece Terminal Boards for Control Circuit



Application

These molded terminal boards are for use in wiring of control panels. A write-on strip markable with ink or pencil is included. Terminal boards may be mounted end-to-end without spacing.

Features

- Electrical rating – 30 amperes, 600 volts
- Rugged material – phenolic
- Number of points per board – 4, 6, 12, or 13
- Mounting – may be mounted end-to-end without spacing
- Terminal identification – 15/32-inch wide marking strip; markable with ink or pencil
- Wiring – terminals accept wire sizes through AWG # 10

GE Limitamp® Medium Voltage Motor Control

Application Data

Standard Service Conditions

Limitamp equipment is designed for the following standard conditions: Operating ambient temperature -20° C to 40° C. Storage ambient temperatures -40° C to 70° C; strip heaters with thermostat control are recommended at 0° C. One heater per enclosure. Thermostats may control up to 14 heaters.

- Altitude to 3,300 feet above sea level
- Humidity 0 to 90 percent (non-condensing)

Seismic Capability

Vacuum Limitamp Controllers can be used in various applications subject to shock and/or vibration. Certain controllers will withstand forces generated by a Zone 4 earthquake as defined in 1985 uniform building code for non-essential equipment when properly anchored at ground level.

For Limitamp control with seismic capability, or other vibration-type applications, refer your application details to the factory.

Applicable ratings are:

Qualified to IEEE-693-1997 HIGH level with 2.5 amplification factor

Qualified to IBC-2003 $S_{ds} = 2.0g$, $S_s = 300\%$, $I_p = 1.5$, for all z/h in accordance with ICC-ES-AC156.

Altitude Derating

Vacuum Limitamp Controllers, including power fuses, require the following derating for use at high altitudes:

For current No derating required up to 6000 feet above sea level.

Above 6,000 feet, derate by 0.9 percent for every 1,000 feet above sea level.

For voltage No derating required up to 3,300 feet above sea level.

Above 3,300 feet, derate by 2 percent for every 1,000 feet above sea level. BIL rating is also derated by the same percentage.

Temperature Derating

Vacuum Limitamp Controllers require the following current derating for ambient temperature.

- Up to 40° C — No derating
- 40-45° C — Derate 10 percent
- 45-50° C — Derate 20 percent

Estimated Heat Loss

The following data can be used for estimating heat loss of Limitamp controllers at rated load amps. The estimates are based upon a single full-voltage non-reversing 400 ampere induction motor controller with basic panel options.

- CR194 Vacuum - 370 watts per contactor

Standards and Codes

Limitamp controllers are designed to meet NEMA Standard ICS 3, Part 2 for Class E2 Controllers, and UL Standard 347 for high-voltage industrial control equipment under UL File E57411.

Each UL-listed section includes a UL section nameplate and each UL-listed motor controller includes a UL controller label.

Additional information can be found in Table A.3.

GE UL-Listed Vacuum Controllers

- A. Full-voltage non-reversing induction motor starters, 2400-4800 volts, up to 400 amperes rating.
- B. CR194 one-high NEMA 1 enclosure, 26W or 34W x 90H x 30D, with stationary mounted vacuum contactor and DC operating coil. CR194 two-high or one-high NEMA 1 enclosure, 36W or 40W x 90H x 30D, with stationary or drawout mounted vacuum contactor and DC operating coil.
- C. GE Type RA or RB current limiting power fuses.
- D. Ambient compensated thermal overload relays (CR324C).
- E. Solid state overload (CR324CX).
- F. 1200, 2000 or 3000 amp copper main bus.
- G. Phase and ground current transformers.
- H. Control power transformer with primary and secondary fuse protection.

Approved Components For GE Controllers

- A. Any UL-listed low-voltage component
 - B. Current transformers
 - C. Control wire, Type MTW, THW, SIS, XHHN
 - D. Power wire — MV-90 Dry
 - E. Control power transformers
- See Table A.3 for details.

Standard Paint System — Indoor & Outdoor Equipment

The standard Limitamp paint system consists of the following two processes:

Phase I — Cleaning

In a seven-stage spray washer, steel parts are cleaned and sprayed in controlled cleaning solutions. Cleaned steel parts enter a drying oven at 300-350° F.

| Stage | Temperature | Chemical Solution(s) |
|---------------------|-------------|----------------------|
| 1 — Cleaning | 115-120° | Ridoline |
| 2 — Rinse | 105-118° | Bonderite |
| 3 — Iron Phosphate | 90-105° | Bonderite, Soda Ash |
| 4 — Rinse | Ambient | None |
| 5 — Acidated Rinse | Ambient | Parcolene |
| 6 — Rinse | Ambient | None |
| 7 — Deionized Rinse | Ambient | None |

GE Limitamp® Medium Voltage Motor Control

Application Data

The preceding operating parameters have been determined to produce an Iron Phosphate coating of a minimum of 150 milligrams per square foot to meet MIL Spec. TT-C-490.

Phase II — Painting by electro-static powder process

670-011 ANSI-61 Polyester Finish Paint (Light Gray)
Metal parts will enter a drying oven at 375-400° F and remain for 20 minutes. The standard color finish is ANSI-61 light gray with a gloss of 60 plus or minus five and a thickness of 2.5 mils. This system will withstand a minimum of 1000 hours salt spray test.

Standard Commercial Tests and Inspections

General

The following summary description defines the standard factory tests and inspections performed during manufacture of Limitamp Control. All Limitamp equipment is tested and inspected for conformance with NEMA ICS 3 part 2 and UL347.

Production tests and inspections encompass the verification of physical configuration of assembly and workmanship, the mechanical adjustments of parts and components, and the sequencing and functional operations of the control systems. These tests and inspections are performed on manufactured products to verify conformance of the equipment to a previously qualified design. The tests do not include type testing or other destructive tests on equipment to be shipped to a customer.

Any additional factory tests beyond those listed in the following paragraphs must be referred to the factory to verify availability of test facilities and qualified manpower. Additional testing beyond the scope of the following standard commercial tests will affect normal shipment schedules.

Production Tests

The following list of inspection activities shall be performed to assure proper and correct materials, workmanship and for any damage conditions in accordance with the manufacturing documentation and drawings:

- Components, parts and material
- Physical condition of components, parts, wire insulation
- Location and orientation of components and parts
- Finish - plating - painting
- Wire/cable type, size, insulating and clamping support
- Wire terminations, insulation removal and crimping of terminals
- Tightness of electrical connections and torque of bus bar bolts
- Wire markers and terminal markers (where specified)
- Labeling of components, parts, etc.
- Tightness torque of assembly bolts and hardware
- Welds (spot only)
- Mechanical clearance
- Electrical clearance (potential hazards)

Mechanical Operation Tests

Mechanical operating tests shall be performed to ensure proper functioning of operating mechanisms and interlocks. The operation of shutters, mechanical interlocks, circuit-breaker-door interlocks, operating handles, trip mechanisms, solenoid armature travels, contact wipes, electro-mechanical interlocks, physical clearances for mechanical and electrical isolation including any additional mechanically related operating functions shall be verified.

Continuity Tests — Control Wiring And Power Cables

The correctness of the individual circuit wiring contained in each assembly and the assembly wiring interfaces shall be verified as in accordance with the connection diagram, wiring table, or elementary drawing. The continuity of each circuit shall be checked.

Operations Test

All equipment shall be subjected to an operational test. The test shall verify the functional operation of the control and power circuits and related components, devices and sub-assembly-modules under simulated operating conditions (excluding loading of the power circuits).

a. Devices

All devices, including subassembly-modules, shall be operated, set and checked for their functional characteristics in accordance with the instructions for each and any additional characteristic peculiar to the device:

- Pick-up
- Drop-out
- Contact wipe
- Amperes
- In-rush current
- Time-delay

Contactors must pick-up and hold-in at or below the following percentage of rated coil voltage:

| Device Type | Voltage Source | Pick-up (Percentage) |
|-------------|-------------------|--------------------------------------|
| DC | DC | 65 |
| AC | AC | 85 ¹ |
| DC | AC with rectifier | 70 with holding resistor |
| DC | AC with rectifier | 70 with holding and pick-up resistor |

¹ If a CPT is used, apply 90% voltage to transformer primary.

b. Sequence and timing circuits

Assemblies and systems involving sequential operation of devices and time delays shall be tested to assure that the devices in the sequence function properly and in the order intended.

c. Polarity — phase-sensitive circuits

The polarity of direct-current circuits and phase connections of alternating-current circuits shall be verified by application of power and measurement of the relative polarities and phase sequence.

d. Grounding

The grounding circuits and buses shall be verified.

GE Limitamp® Medium Voltage Motor Control

Application Data



High Potential — Insulation Tests

a. Control wiring insulation tests

A dielectric test (hi-pot) shall be performed on circuit wiring to confirm the insulation resistance to withstand breakdown to a selected test voltage. The test voltage — amplitude and waveshape, method of application and duration of time applied — shall be specified in UL347.

b. Power cable insulation and isolation test

Power cables and buses shall be tested, phase-to-phase and phase-to-ground for insulation breakdown resistance and circuit isolation as specified in UL347.

Note: These test conditions are as specified for newly constructed equipment and performed in a clean, temperature and humidity controlled factory environment.

| Rated Circuit Voltage AC or DC | High Potential Test Voltage | Duration of Test |
|-----------------------------------|--------------------------------|------------------|
| 120 | 1500 | 1 second |
| 140 | 1800 | 1 second |
| 480/600 | 2700 | 1 second |
| 2300 | 7200 | 60 seconds |
| 5000 | 13,250 | 60 seconds |
| 7200 | 18200 | 60 seconds |

These test voltages include the standard test voltages:

a. For equipment rated under 600 volts RMS or DC:

2 times rated plus 1000, times 120 percent (for one-second application).

b. For equipment rated over 600 volts RMS or DC:

2.25 times rated plus 2000 (60 seconds only).

The frequency of the test voltage shall not be less than the rated frequency of the equipment tested and shall be essentially sinusoidal in wave shape.

Note: Consideration shall be made for low-voltage devices, semiconductors, meters, instruments, transformers, grounding circuits, etc., in preparation for the dielectric tests.

Insulation Resistance (Megger) Tests

Insulation resistance tests measure the amount of circuit resistance to current leakage. This test is performed when this resistance measurement is desired and so specified. The test voltage and minimum insulation resistance shall be selected as specified. Examples of test values are:

- a. 500 volts DC with 10 megohms minimum
- b. 1000 volts DC with 1 megohm minimum
- c. 1000 volts DC with 25 megohms minimum

Desired values must be specified by the customer, as no NEMA standard defines Megger values for motor controls.

GE Limitamp® Medium Voltage Motor Control

Application Data

ANSI Standard Device Function Numbers

| Dev. No. | Function |
|----------|--|
| 1 | Master Element |
| 2 | Time-Delay Starting or Closing Relay |
| 3 | Checking or Interlocking Relay |
| 4 | Master Contactor |
| 5 | Stopping Device |
| 6 | Starting Circuit Breaker |
| 7 | Anode Circuit Breaker |
| 8 | Control Power Disconnecting Device |
| 9 | Reversing Device |
| 10 | Unit Sequence Switch |
| 11 | (Reserved for future application) |
| 12 | Over-Speed Device |
| 13 | Synchronous-Speed Device |
| 14 | Under-Speed Device |
| 15 | Speed or Frequency Matching Device |
| 16 | (Reserved for future application) |
| 17 | Shunting or Discharge Switch |
| 18 | Accelerating or Decelerating Device |
| 19 | Starting-to-Running Transition Contactor |
| 20 | Electrically Operated Valve |
| 21 | Distance Relay |
| 22 | Equalizer Circuit Breaker |
| 23 | Temperature Control Device |
| 24 | (Reserved for future application) |
| 25 | Synchronizing or Synchronism-Check Device |
| 26 | Apparatus Thermal Device |
| 27 | Undervoltage Relay |
| 28 | Flame Detector |
| 29 | Isolating Contactor |
| 30 | Annunciator Relay |
| 31 | Separate Excitation Device |
| 32 | Directional Power Relay |
| 33 | Position Switch |
| 34 | Master Sequence Device |
| 35 | Brush-Operating or Slip-Ring Short-Circuiting Device |
| 36 | Polarity or Polarizing Voltage Device |
| 37 | Undercurrent or Underpower Relay |
| 38 | Bearing Protective Device |
| 39 | Mechanical Condition Monitor |
| 40 | Field Relay |
| 41 | Field Circuit Breaker |
| 42 | Running Circuit Breaker |
| 43 | Manual Transfer or Selector Device |
| 44 | Unit Sequence Starting Relay |
| 45 | Atmospheric Condition Monitor |
| 46 | Reverse-Phase or Phase-Balance Current Relay |
| 47 | Phase-Sequence Voltage Relay |
| 48 | Incomplete Sequence Relay |
| 49 | Machine or Transformer Thermal Relay |
| 50 | Instantaneous Overcurrent or Rate-of-Rise Relay |

| Dev. No. | Function |
|----------|--|
| 51 | AC Time Overcurrent Relay |
| 52 | AC Circuit Breaker |
| 53 | Exciter or DC Generator Relay |
| 54 | (Reserved for future application) |
| 55 | Power Factor Relay |
| 56 | Field Application Relay |
| 57 | Short-Circuiting or Ground Device |
| 58 | Rectification Failure Relay |
| 59 | Overvoltage Relay |
| 60 | Voltage or Current Balance Relay |
| 61 | (Reserved for future application) |
| 62 | Time-Delay Stopping or Opening Relay |
| 63 | Pressure Switch |
| 64 | Ground Protective Relay |
| 65 | Governor |
| 66 | Notching or Jogging Device |
| 67 | AC Directional Overcurrent Relay |
| 68 | Blocking Relay |
| 69 | Permissive Control Device |
| 70 | Rheostat |
| 71 | Level Switch |
| 72 | DC Circuit Breaker |
| 73 | Load-Resistor Contactor |
| 74 | Alarm Relay |
| 75 | Position Changing Mechanism |
| 76 | DC Reclosing Relay |
| 77 | Pulse Transmitter |
| 78 | Phase-Angle Measuring or Out-of-Step Protective Relay |
| 79 | AC Reclosing Relay |
| 80 | Flow Switch |
| 81 | Frequency Relay |
| 82 | DC Overcurrent Relay |
| 83 | Automatic Selective Control or Transfer Relay |
| 84 | Operating Mechanism |
| 85 | Carrier or Pilot-Wire Receiver Relay |
| 86 | Locking-Out Relay |
| 87 | Differential Protective Relay |
| 88 | Auxiliary Motor or Motor Generator |
| 89 | Line Switch |
| 90 | Regulating Device |
| 91 | Voltage Directional Relay |
| 92 | Voltage and Power Directional Relay |
| 93 | Field-Changing Contactor |
| 94 | Tripping or Trip-Free Relay |
| 95 | |
| 96 | Used only for specific applications in individual installations where none of the assigned numbered functions from 1 to 94 are suitable. |
| 97 | |
| 98 | |
| 99 | |

GE Limitamp® Medium Voltage Motor Control

Application Data

Table H.1 Motor Current Limiting Fuse And Current Transformer Ratio Selection (For Estimating Only) Based Upon 600% Locked Rotor Current

| Motor Horsepower | 2400 volts | | | 4160 volts | | |
|------------------|-------------|----------|------------|-------------|----------|------------|
| | Typical FLA | CT Ratio | EJ2 Rating | Typical FLA | CT Ratio | EJ2 Rating |
| 150 | 35 | 50/5 | 3R | 20 | 25/5 | 3R |
| 200 | 46 | 75/5 | 4R | 25 | 40/5 | 3R |
| 250 | 57 | 75/5 | 4R | 33 | 50/5 | 3R |
| 300 | 69 | 100/5 | 6R | 41 | 75/5 | 3R |
| 350 | 81 | 150/5 | 6R | 47 | 75/5 | 4R |
| 400 | 92 | 150/5 | 6R | 54 | 75/5 | 4R |
| 450 | 105 | 150/5 | 9R | 60 | 75/5 | 4R |
| 500 | 113 | 150/5 | 9R | 66 | 100/5 | 6R |
| 550 | 123 | 200/5 | 9R | 73 | 100/5 | 6R |
| 600 | 135 | 200/5 | 9R | 80 | 100/5 | 6R |
| 650 | 145 | 200/5 | 12R | 87 | 150/5 | 6R |
| 700 | 155 | 200/5 | 12R | 93 | 150/5 | 6R |
| 750 | 166 | 300/5 | 12R | 100 | 150/5 | 9R |
| 800 | 176 | 300/5 | 12R | 106 | 150/5 | 9R |
| 850 | 186 | 300/5 | 12R | 113 | 150/5 | 9R |
| 900 | 197 | 300/5 | 18R | 120 | 150/5 | 9R |
| 950 | 207 | 300/5 | 18R | 126 | 200/5 | 9R |
| 1000 | 218 | 300/5 | 18R | 133 | 200/5 | 9R |
| 1200 | 266 | 400/5 | 18R | 152 | 200/5 | 12R |
| 1250 | 279 | 400/5 | 18R | 158 | 200/5 | 12R |
| 1500 | | | | 187 | 300/5 | 12R |
| 1750 | | | | 217 | 300/5 | 18R |
| 2000 | | | | 246 | 400/5 | 18R |

Table H.4 Fuse Ratings For Transformer Feeders (For Estimating Only)

| Three-Phase Transformer | 2400 volts | | 4160 volts | |
|-------------------------|-------------------|------|-------------------|------|
| | Full Load Current | Fuse | Full Load Current | Fuse |
| 9 | 2.16 | 7E | 1.25 | 5E |
| 15 | 3.6 | 10E | 2.08 | 7E |
| 30 | 7.2 | 20E | 4.2 | 15E |
| 45 | 10.8 | 25E | 6.2 | 15E |
| 75 | 18 | 30E | 10.4 | 25E |
| 112.5 | 27 | 40E | 15.6 | 30E |
| 150 | 36 | 50E | 20.8 | 40E |
| 225 | 54 | 65E | 31.3 | 50E |
| 300 | 72 | 100E | 41.6 | 50E |
| 500 | 120 | 150E | 69.4 | 80E |
| 750 | 180 | 200E | 104 | 125E |
| 1000 | 240 | 250E | 139 | 150E |
| 1500 | 361 | 400E | 208 | 250E |
| 2000 | — | — | 278 | 300E |
| 2500 | — | — | 347 | 400E |

Table H.2 CT Ratio Based on Rated Load Current

| Current | CT Ratio | Current | CT Ratio |
|---------|----------|----------|----------|
| 10-14A | 20/5 | 121-160A | 200/5 |
| 15-24A | 30/5 | 161-255A | 300/5 |
| 25-40A | 50/5 | 256-355A | 400/5 |
| 41-60A | 75/5 | 356-480A | 600/5 |
| 61-80A | 100/5 | 481-670A | 800/5 |
| 81-120A | 150/5 | | |

Table H.3 Fuse Selection Based On Full Load Current

| FUSE SELECTIONS (Assumes 600% locked rotor) | |
|---|------|
| 0-44A | 3R |
| 45-62A | 4R |
| 63-94A | 6R |
| 95-140A | 9R |
| 141-184A | 12R |
| 185-276A | 18R |
| 277-360A | 24R |
| 361-408A | P425 |
| 409-510A | P550 |
| 511-630A | P630 |
| 631-800A | P800 |

H

GE Limitamp® Medium Voltage Motor Control

Application Data

Estimating Power Factor Correction Capacitor Ratings

Table H.5 2400-Volt and 4160-Volt Motors, Enclosure Open – Including Drip-proof and Splash-proof, GE Type K (NEMA Design “B”), Normal Starting Torque and Current

| Induction Motor HP Rating | Nominal Motor Speed in RPM | | | | | | | | | | | |
|---------------------------|----------------------------|------|------|------|------|------|------|------|------|------|------|------|
| | Number of Poles | | | | | | | | | | | |
| | 3600 | | 1800 | | 1200 | | 900 | | 720 | | 600 | |
| | 2 | | 4 | | 6 | | 8 | | 10 | | 12 | |
| | kVAr | % AR | kVAr | % AR | kVAr | % AR | kVAr | % AR | kVAr | % AR | kVAr | % AR |
| 100 | — | — | 25 | 11 | 25 | 12 | 50 | 24 | 25 | 14 | 25 | 20 |
| 125 | — | — | 25 | 9 | 25 | 12 | 25 | 13 | 25 | 14 | 50 | 20 |
| 150 | 25 | 9 | 25 | 9 | 25 | 12 | 50 | 13 | 50 | 14 | 75 | 20 |
| 200 | 25 | 9 | 50 | 9 | 50 | 12 | 50 | 13 | 75 | 14 | 100 | 20 |
| 250 | 25 | 9 | 25 | 8 | 50 | 12 | 75 | 13 | 75 | 14 | 100 | 20 |
| 300 | 50 | 9 | 50 | 8 | 75 | 12 | 100 | 13 | 100 | 14 | 125 | 20 |
| 350 | 75 | 9 | 50 | 8 | 75 | 12 | 100 | 12 | 100 | 14 | 125 | 19 |
| 400 | 75 | 9 | 50 | 8 | 100 | 12 | 100 | 12 | 125 | 14 | 150 | 19 |
| 450 | 100 | 9 | 75 | 8 | 100 | 12 | 125 | 11 | 125 | 14 | 150 | 19 |
| 500 | 100 | 9 | 100 | 8 | 125 | 12 | 125 | 11 | 150 | 14 | 200 | 19 |
| 600 | 125 | 9 | 125 | 8 | 175 | 12 | 150 | 11 | 150 | 14 | 200 | 17 |
| 700 | 150 | 8 | 150 | 8 | 200 | 11 | 150 | 10 | 200 | 14 | 200 | 15 |
| 800 | 175 | 8 | 150 | 7 | 175 | 10 | 175 | 10 | 225 | 13 | 250 | 15 |

Table H.6 2400-Volt and 4160-Volt Motors, Totally Enclosed, Fan-cooled, GE Type K (NEMA design “B”), Normal Starting

| Induction Motor HP Rating | Nominal Motor Speed in RPM | | | | | | | | | | | |
|---------------------------|----------------------------|------|------|------|------|------|------|------|------|------|------|------|
| | Number of Poles | | | | | | | | | | | |
| | 3600 | | 1800 | | 1200 | | 900 | | 720 | | 600 | |
| | 2 | | 4 | | 6 | | 8 | | 10 | | 12 | |
| | kVAr | % AR | kVAr | % AR | kVAr | % AR | kVAr | % AR | kVAr | % AR | kVAr | % AR |
| 100 | — | — | 25 | 17 | — | — | 50 | 22 | 25 | 12 | 50 | 15 |
| 125 | — | — | 50 | 17 | 25 | 15 | 50 | 17 | 25 | 12 | 50 | 15 |
| 150 | 25 | 6 | 25 | 12 | 50 | 15 | 50 | 17 | 50 | 12 | 75 | 15 |
| 200 | 25 | 6 | 50 | 12 | 75 | 15 | 50 | 17 | 50 | 12 | 100 | 15 |
| 250 | 25 | 6 | 50 | 11 | 75 | 15 | 75 | 17 | 75 | 12 | 100 | 15 |
| 300 | 50 | 6 | 50 | 11 | 75 | 13 | 125 | 17 | 100 | 12 | 125 | 15 |
| 350 | 50 | 6 | 60 | 11 | 75 | 13 | 125 | 17 | 125 | 12 | 150 | 15 |
| 400 | 75 | 6 | 125 | 11 | 125 | 13 | 150 | 17 | 150 | 12 | 200 | 15 |
| 450 | 75 | 6 | 125 | 10 | 150 | 13 | 175 | 17 | 200 | 12 | 225 | 15 |
| 500 | 75 | 6 | 125 | 8 | 175 | 13 | 225 | 17 | 225 | 12 | 225 | 15 |

Table H.7 2400-Volt and 4160-Volt Motors, Enclosure Open – Including Drip-proof And Splash-proof, GE Type KG (NEMA design “C”), High-starting Torque, Normal Starting Current

| Induction Motor HP Rating | Nominal Motor Speed in RPM | | | | | | | |
|---------------------------|----------------------------|------|------|------|------|------|------|------|
| | Number of Poles | | | | | | | |
| | 1800 | | 1200 | | 900 | | 720 | |
| | 4 | | 6 | | 8 | | 10 | |
| | kVAr | % AR | kVAr | % AR | kVAr | % AR | kVAr | % AR |
| 100 | — | — | — | — | — | — | 25 | 14 |
| 125 | 25 | 10 | 25 | 11 | 25 | 13 | 25 | 14 |
| 150 | 25 | 8 | 25 | 9 | 50 | 13 | 50 | 14 |
| 200 | 25 | 7 | 50 | 12 | 50 | 13 | 75 | 14 |
| 250 | 25 | 8 | 50 | 12 | 75 | 13 | 75 | 14 |
| 300 | 50 | 8 | 75 | 12 | 100 | 13 | 100 | 14 |
| 350 | 50 | 8 | 75 | 12 | 100 | 12 | 100 | 14 |

Table H.8 2400-Volt and 4160-Volt Motors, Totally Enclosed, Fan-cooled, GE Type KG (NEMA Design “C”), High-starting Torque, Normal Starting Current

| Induction Motor HP Rating | Nominal Motor Speed in RPM | | | | | | | |
|---------------------------|----------------------------|------|------|------|------|------|------|------|
| | Number of Poles | | | | | | | |
| | 1200 | | 900 | | 720 | | 600 | |
| | 6 | | 8 | | 10 | | 12 | |
| | kVAr | % AR | kVAr | % AR | kVAr | % AR | kVAr | % AR |
| 75 | — | — | — | — | — | — | — | — |
| 100 | — | — | — | — | 25 | 12 | 50 | 15 |
| 125 | 25 | 10 | 50 | 17 | 25 | 12 | 50 | 15 |
| 150 | — | — | 50 | 17 | 50 | 12 | 75 | 15 |
| 200 | 75 | 15 | 50 | 17 | 50 | 12 | 100 | 15 |

GE Limitamp® Medium Voltage Motor Control

Application Data

Estimated Typical Kw Ratings Of Exciters For 60-Hertz Synchronous Motors

When synchronous motors have individual exciters, the kilowatt ratings in Table H.7 represent typical kilowatt ratings for such exciters.

Table H.9 Exciter ratings for synchronous motors, 60 Hz, 1.0 power factor

| | | Exciter Ratings, kW | | | | | | | | | | | | |
|------|-----|---------------------|------|-----|-----|-----|-----|-----|-----|-----|-----|-----|-----|-----|
| HP | RPM | 1800 | 1200 | 900 | 720 | 600 | 514 | 450 | 400 | 360 | 300 | 240 | 200 | 180 |
| 200 | | 2.0 | 3.0 | 3.0 | 3.0 | 4.5 | 4.5 | 4.5 | 4.5 | 4.5 | 6.5 | 6.5 | 6.5 | 6.5 |
| 250 | | 2.0 | 3.0 | 3.0 | 4.5 | 4.5 | 4.5 | 4.5 | 6.5 | 6.5 | 6.5 | 6.5 | 9.0 | 9.0 |
| 300 | | 2.0 | 3.0 | 4.5 | 4.5 | 4.5 | 4.5 | 6.5 | 6.5 | 6.5 | 6.5 | 9.0 | 9.0 | 9.0 |
| 350 | | 3.0 | 3.0 | 4.5 | 4.5 | 4.5 | 6.5 | 6.5 | 6.5 | 6.5 | 6.5 | 9.0 | 9.0 | 9.0 |
| 400 | | 3.0 | 3.0 | 4.5 | 4.5 | 6.5 | 6.5 | 6.5 | 6.5 | 6.5 | 9.0 | 9.0 | 9.0 | 13 |
| 450 | | 3.0 | 4.5 | 4.5 | 4.5 | 6.5 | 6.5 | 6.5 | 9.0 | 9.0 | 9.0 | 9.0 | 13 | 13 |
| 500 | | 3.0 | 4.5 | 4.5 | 4.5 | 6.5 | 6.5 | 6.5 | 9.0 | 9.0 | 9.0 | 9.0 | 13 | 13 |
| 600 | | 3.0 | 4.5 | 6.5 | 6.5 | 6.5 | 6.5 | 9.0 | 9.0 | 9.0 | 9.0 | 13 | 13 | 13 |
| 700 | | 4.5 | 4.5 | 6.5 | 6.5 | 6.5 | 9.0 | 9.0 | 9.0 | 9.0 | 13 | 13 | 13 | 13 |
| 800 | | 4.5 | 6.5 | 6.5 | 6.5 | 9.0 | 9.0 | 9.0 | 13 | 13 | 13 | 13 | 13 | 13 |
| 900 | | 4.5 | 6.5 | 6.5 | 9.0 | 9.0 | 9.0 | 9.0 | 13 | 13 | 13 | 13 | 17 | 17 |
| 1000 | | 4.5 | 6.5 | 9.0 | 9.0 | 9.0 | 9.0 | 12 | 13 | 13 | 13 | 13 | 17 | 17 |
| 1250 | | 6.5 | 6.5 | 9.0 | 9.0 | 13 | 13 | 12 | 13 | 13 | 13 | 17 | 17 | 17 |
| 1500 | | 6.5 | 9.0 | 9.0 | 13 | 13 | 13 | 12 | 17 | 17 | 17 | 17 | 21 | 21 |
| 1750 | | 9.0 | 9.0 | 13 | 13 | 13 | 13 | 17 | 17 | 17 | 17 | 21 | 21 | 21 |
| 2000 | | 9.0 | 13 | 13 | 13 | 13 | 17 | 17 | 17 | 17 | 21 | 21 | 21 | 25 |
| 2250 | | 9.0 | 13 | 13 | 13 | 17 | 17 | 17 | 21 | 21 | 21 | 21 | 25 | 25 |
| 2500 | | 13 | 13 | 13 | 17 | 17 | 17 | 21 | 21 | 21 | 21 | 25 | 25 | 25 |
| 3000 | | 13 | 13 | 17 | 17 | 17 | 21 | 21 | 21 | 21 | 25 | 25 | 33 | 33 |
| 3500 | | 13 | 17 | 17 | 21 | 21 | 21 | 25 | 25 | 25 | 25 | 33 | 33 | 33 |
| 4000 | | 17 | 17 | 21 | 21 | 21 | 25 | 25 | 33 | 33 | 33 | 33 | 33 | 40 |
| 4500 | | 17 | 21 | 21 | 21 | 25 | 25 | 33 | 33 | 33 | 33 | 33 | 40 | 40 |
| 5000 | | 17 | 21 | 25 | 25 | 33 | 33 | 33 | 33 | 33 | 33 | 40 | 40 | 40 |
| 5500 | | 21 | 25 | 25 | 25 | 33 | 33 | 33 | 33 | 33 | 33 | 40 | 40 | 40 |
| 6000 | | 21 | 25 | 33 | 33 | 33 | 33 | 33 | 40 | 40 | 40 | 40 | 50 | 50 |

Table H.10 Exciter ratings for synchronous motors, 60 Hz, 0.8 power factor

| | | Exciter Ratings, kW | | | | | | | | | | | | |
|------|-----|---------------------|------|-----|-----|-----|-----|-----|-----|-----|-----|-----|-----|-----|
| HP | RPM | 1800 | 1200 | 900 | 720 | 600 | 514 | 450 | 400 | 360 | 300 | 240 | 200 | 180 |
| 200 | | 3.0 | 4.5 | 4.5 | 4.5 | 6.5 | 6.5 | 6.5 | 9.0 | 9.0 | 9.0 | 13 | 13 | 13 |
| 250 | | 3.0 | 4.5 | 6.5 | 6.5 | 6.5 | 6.5 | 9.0 | 9.0 | 9.0 | 9.0 | 13 | 13 | 13 |
| 300 | | 3.0 | 4.5 | 6.5 | 6.5 | 6.5 | 9.0 | 9.0 | 9.0 | 9.0 | 13 | 13 | 13 | 13 |
| 350 | | 4.5 | 4.5 | 6.5 | 6.5 | 9.0 | 9.0 | 9.0 | 9.0 | 9.0 | 13 | 13 | 13 | 17 |
| 400 | | 4.5 | 6.5 | 6.5 | 6.5 | 9.0 | 9.0 | 13 | 13 | 13 | 13 | 13 | 13 | 17 |
| 450 | | 4.5 | 6.5 | 6.5 | 9.0 | 9.0 | 9.0 | 13 | 13 | 13 | 13 | 17 | 17 | 17 |
| 500 | | 4.5 | 6.5 | 6.5 | 9.0 | 9.0 | 9.0 | 13 | 13 | 13 | 13 | 17 | 17 | 17 |
| 600 | | 6.5 | 6.5 | 9.0 | 9.0 | 13 | 13 | 13 | 13 | 13 | 17 | 17 | 17 | 21 |
| 700 | | 6.5 | 9.0 | 9.0 | 9.0 | 13 | 13 | 13 | 13 | 13 | 17 | 17 | 17 | 21 |
| 800 | | 6.5 | 9.0 | 9.0 | 13 | 13 | 13 | 17 | 17 | 17 | 17 | 21 | 21 | 21 |
| 900 | | 6.5 | 9.0 | 13 | 13 | 13 | 13 | 17 | 17 | 17 | 17 | 21 | 21 | 25 |
| 1000 | | 9.0 | 9.0 | 13 | 13 | 13 | 17 | 17 | 17 | 17 | 21 | 21 | 21 | 25 |
| 1250 | | 9.0 | 13 | 13 | 13 | 17 | 17 | 21 | 21 | 21 | 21 | 25 | 25 | 33 |
| 1500 | | 13 | 13 | 17 | 17 | 17 | 17 | 21 | 21 | 21 | 25 | 25 | 25 | 33 |
| 1750 | | 13 | 13 | 17 | 17 | 21 | 21 | 25 | 25 | 25 | 25 | 33 | 33 | 33 |
| 2000 | | 13 | 17 | 17 | 21 | 21 | 21 | 25 | 25 | 25 | 33 | 33 | 33 | 40 |
| 2250 | | 13 | 17 | 21 | 21 | 25 | 25 | 33 | 33 | 33 | 33 | 33 | 33 | 40 |
| 2500 | | 17 | 17 | 21 | 21 | 25 | 25 | 33 | 33 | 33 | 33 | 40 | 40 | 40 |
| 3000 | | 17 | 21 | 25 | 25 | 33 | 33 | 33 | 33 | 33 | 40 | 40 | 40 | 50 |
| 3500 | | 21 | 25 | 25 | 33 | 33 | 33 | 40 | 40 | 40 | 40 | 50 | 50 | 50 |
| 4000 | | 21 | 25 | 33 | 33 | 33 | 40 | 40 | 40 | 40 | 50 | 50 | 50 | 65 |
| 4500 | | 25 | 33 | 33 | 33 | 40 | 40 | 50 | 50 | 50 | 50 | 50 | 50 | 65 |
| 5000 | | 33 | 33 | 40 | 40 | 40 | 40 | 50 | 50 | 50 | 50 | 65 | 65 | 65 |
| 5500 | | 33 | 33 | 40 | 40 | 50 | 50 | 50 | 50 | 50 | 65 | 65 | 65 | 65 |
| 6000 | | 33 | 40 | 40 | 50 | 50 | 50 | 65 | 65 | 65 | 65 | 65 | 65 | 85 |

GE Limitamp® Medium Voltage Motor Control

Typical Elementary Diagrams

Limitamp Control Standard Nomenclature

| | | | | | |
|----------|-----------------------------------|-------------|---|----------|-------------------------------------|
| 1AM | AC AMMETER | GIL | GREEN INDICATING LIGHT | S | START CONTACTOR |
| 2AM | DC AMMETER | GND | GROUND | SC | SURGE CAPACITOR |
| A | ACCELERATING CONTACTOR | GRB | GROUND BUS | SFC | STATIC FIELD CONTACTOR |
| AIL | AMBER INDICATING LIGHT | GS | GROUND SENSOR | SH | SHUNT |
| AM | AMMETER | H1.H2.H3 | OUTGOING TERMINALS TO TRANSFORMER | SHAM | SPACE HEATER AMMETER |
| AMS | AMMETER SWITCH | HAM | HEATER AMMETER | SP HTR | SPACE HEATER |
| AT | AUTOTRANSFORMER | ISW | ISOLATING SWITCH | SPR | STALL PROTECTIVE RELAY |
| AX | ACCELERATION TIMING RELAY | ISR | INCOMPLETE SEQUENCE RELAY | SR | STARTING REACTOR |
| BFI | BLOWN FUSE INDICATOR | KX | ANTI-KISS RELAY | SR735 | MULTILIN FEEDER RELAY |
| BFIPS | BLOWN FUSE INDICATOR POWER SUPPLY | L.O. | LATE OPENING | SR737 | MULTILIN FEEDER RELAY |
| BFT | BLOWN FUSE TRIP | L1.L2.L3 | INCOMING TERMINALS OR AC BUS | SS | SLOW SPEED CONTACTOR |
| BIL | BLUE INDICATING LIGHT | LA | LIGHTNING ARRESTOR | SS1 | SLOW SPEED SHORTING CONTACTOR |
| C | CAPACITOR | LIT | LIGHT | SSW | SELECTOR SWITCH |
| CC | CLOSING COIL | LOR | LOCKOUT RELAY | SSX | AUX. RELAY TO SS |
| CB | CIRCUIT BREAKER | LSW | LIGHT SWITCH | ST | STAB |
| CD | CALIFORNIA DISCONNECT | M239 | MULTILIN MOTOR PROTECTION RELAY | STB | SHORTING TERMINAL BOARD |
| CEM | CONTACTOR ECONOMIZING MODULE | M269 | MULTILIN MOTOR MANAGEMENT RELAY | SX | AUX. RELAY TO S |
| CM | FIELD CURRENT CALIBRATION MODULE | M269+ | MULTILIN MOTOR MANAGEMENT & COMMUNICATION RELAY | T | TRANSFORMER |
| CPD | CAPACITOR TRIP DEVICE | M369 | M369 MOTOR MANAGEMENT RELAY | TA | AUX. RELAY TO TIMING MODULE |
| CPI | CONTROL POWER INTERLOCK | M469 | M469 MOTOR MANAGEMENT RELAY | TC | TIME CLOSING |
| CPIX | AUX. RELAY TO CPI | M | MAIN CONTACTOR | TDAD | TIME DELAY AFTER DE-ENERGIZATION |
| CPS | CONTACTOR POSITION SWITCH | MOT | MOTOR | TDAE | TIME DELAY AFTER DE-ENERGIZATION |
| CR | CONTROL RELAY | MOV | METAL OXIDE VARISTOR | TO | TIME OPENING |
| CT | CURRENT TRANSFORMER | MR | CONTACTOR HOLDING RESISTOR RELAY | T1.T2.T3 | OUTGOING TERMINALS TO MOTOR |
| CTB | CURRENT TEST BLOCK | MSW | MAIN DISCONNECT SWITCH | TB | TERMINAL BOARD |
| CTD | CURRENT TRANSDUCER | MX | AUX. RELAY TO M | TH | THERMOSTAT |
| D | DIODE | N | NEUTRAL CONTACTOR | TIE | TIE SWITCH |
| DCCT | DC CURRENT TRANSFORMER | NX | AUX. RELAY TO N | TM | TIMING MODULE |
| DR | DIFFERENTIAL RELAY | OC | OPERATIONS COUNTER | TPI | TEST POWER INTERLOCK |
| DSTB | DISCONNECT TERMINAL BOARD | OCR | OVERCURRENT RELAY | TPIX | AUX. RELAY TO TPI |
| DSW | DISCONNECT SWITCH | OL | OVERLOAD RELAY | TPSW | TEST POWER SWITCH |
| EFR | EXCITER FIELD RELAY | OT | OVERTEMPERATURE RELAY | TR | TIMING RELAY |
| EPM | ELECTRONIC POWER METER | OTX | AUX. RELAY TO OT | TRP | TRIP RELAY |
| ETM | ELAPSED TIME METER | PM | POLARITY MARK | TST | THERMOSTAT ON AT OR SR |
| EXC | EXCITER | PB | PUSH BUTTON | TSW | TEST-NORMAL SELECTOR SWITCH |
| EXC RHEO | EXCITER THEOSTAT | PFC | POWER FACTOR CAPACITOR | UC | UNLATCH COIL OR CONTACT |
| F1.F2 | SYNC. MOTOR FIELD LEADS | PFM | POWER FACTOR METER | UL | UNLATCH RELAY |
| FC | FIELD CONTACTOR | PG | PLUG | UV | UNDERVOLTAGE RELAY |
| FCX | AUX. FIELD RELAY | PHA.PHB.PHC | INCOMING LINE TERMINALS | UVTR | UNDERVOLTAGE TIMING RELAY |
| FCY | AUX. FIELD RELAY | PHF | OPEN PHASE & PHASE SEQUENCE RELAY | VCR | VOLTAGE CHECK RELAY |
| FDRS | FIELD DISCHARGE RESISTOR | PLR | POWER LOSS RELAY | VDN | VOLTAGE DIVIDER NETWORK |
| FGRS | FIELD GROUND RESISTOR | PQM | PQM POWER QUALITY METER | VFC | ELECTRONIC VARIABLE FIELD CONTACTOR |
| FLD | SYNC. MOTOR FIELD | PRO | CT PROTECTOR | VFSM | VARIABLE FIELD SUPPLY MODULE |
| FLR | FIELD LOSS RELAY | PT | POTENTIAL TRANSFORMER | VM | VOLTMETER |
| FLTR | FILTER | PTB | POTENTIAL TEST BLOCK | VMS | VOLTMETER SWITCH |
| FRP | FIELD RECTIFIER PANEL | R | RUN OR REVERSE CONTACTOR | VRM | VARMETER |
| FS | FAST SPEED CONTACTOR | REC | RECTIFIER | VRTD | VAR TRANSDUCER |
| FS1 | FAST SPEED SHORTING CONTACTOR | RECP | RECEPTACLE | VT | VARIABLE AUTOTRANSFORMER |
| FSX | AUX. RELAY TO FS | REV | REVERSE CONTACTOR | VTD | VOLTAGE TRANSDUCER |
| FSW | FEEDER SWITCH | RIL | RED INDICATING LIGHT | WHDM | WATTHOUR DEMAND METER |
| FTRS | FIXED TAP RESISTOR | RM | RECTIFIER CONTACTOR | WHM | WATTHOUR METER |
| FU | FUSE | RS | RESISTOR | WM | WATTMETER |
| GCT | GROUND CURRENT TRANSFORMER | RTD | RESISTANCE TEMPERATURE DETECTOR | WTD | WATTS TRANSDUCER |
| GF | GROUND FAULT RELAY | RX | AUX. RELAY TO R | | |
| GFX | AUX. RELAY TO GF | | | | |

This diagram shows starter with the isolating switch in the disconnect position and the test power interlock in the test position.

To test: Handle must be in the disconnect (OFF) position, and test-normal selector switch (located in the low voltage compartment) must be in the TEST position. Purchaser is to connect his test power to the proper terminals and note that the control circuit is not grounded when disconnects are open. Be sure to turn the test-normal switch to NORMAL before moving the disconnect handle to the ON position.

CPI — Opens only when CPI release on isolating switch handle is pushed in. Can not be opened when main line contactor is closed.

- ▲ — Start and stop push buttons are wired through terminal at "TB" in order that remote START-STOP buttons can be readily connected into the circuit when required.
- — At a terminal on "TB", a loop in the CT secondary circuit wire permits insertion of a hook on ammeter for measuring line current.
 - Device furnished by others — mounted remote.
 - Terminal board point.

GE Limitamp® Medium Voltage Motor Control Typical Elementary Diagrams

400A Drawout FVNR with M469 Relay (Stationary also available)

(continued from previous page)

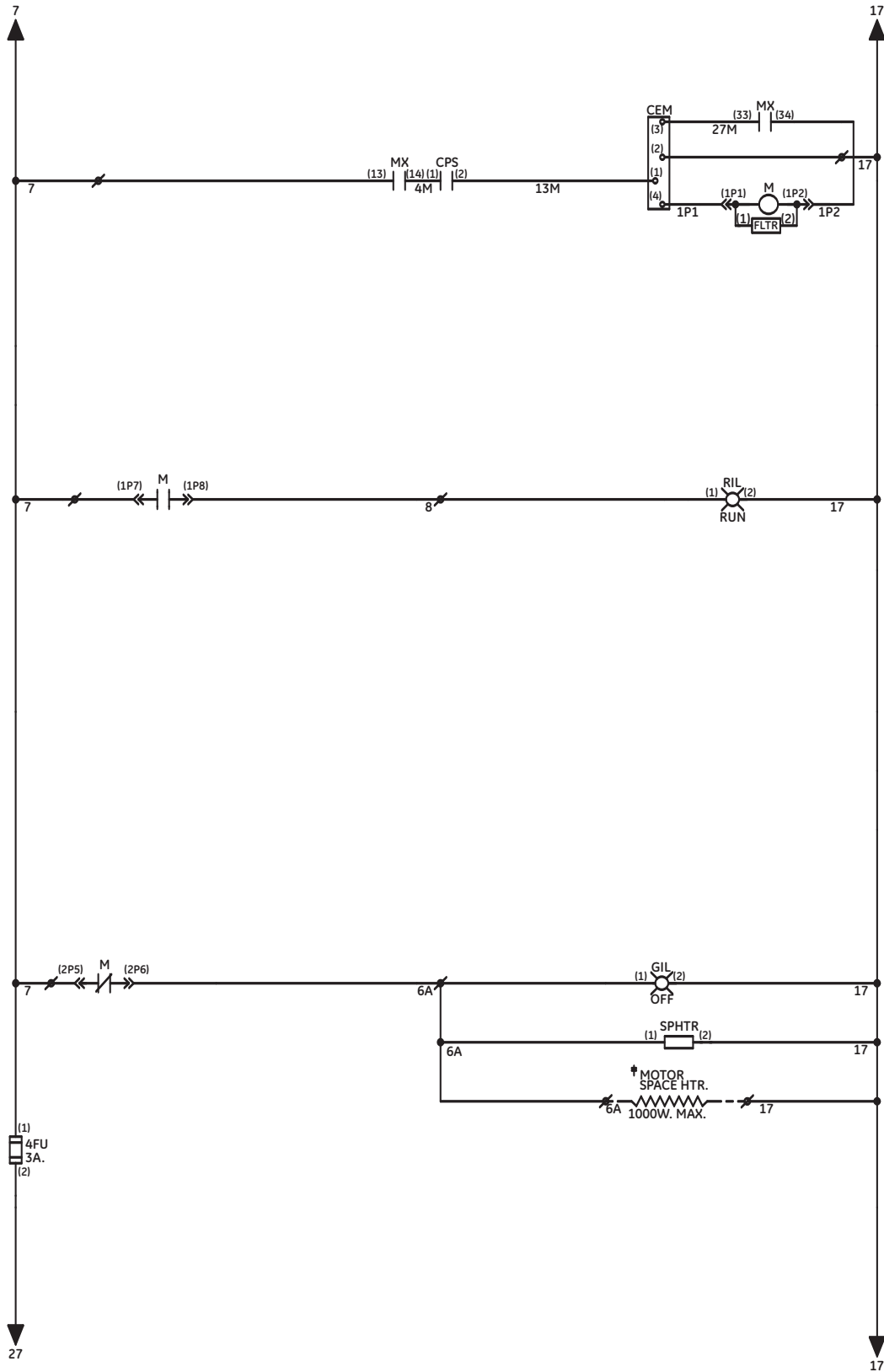

(continued on next page)

GE Limitamp® Medium Voltage Motor Control Typical Elementary Diagrams

400A Drawout FVNR with M469 Relay (Stationary also available)

(continued from previous page)

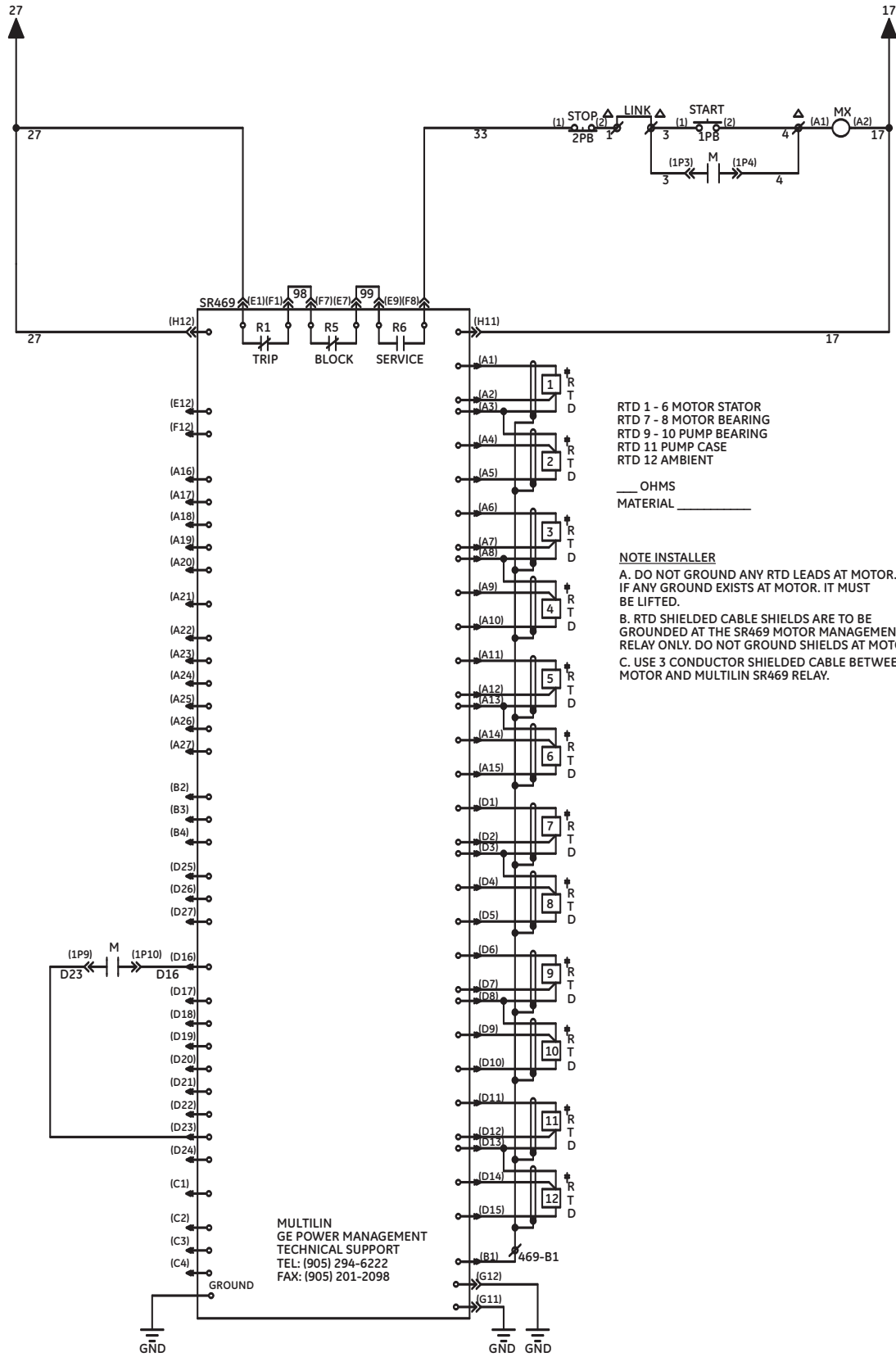

GE Limitamp® Medium Voltage Motor Control Typical Elementary Diagrams

400A Drawout Latched FVNR with M735 Relay

(Stationary also available)

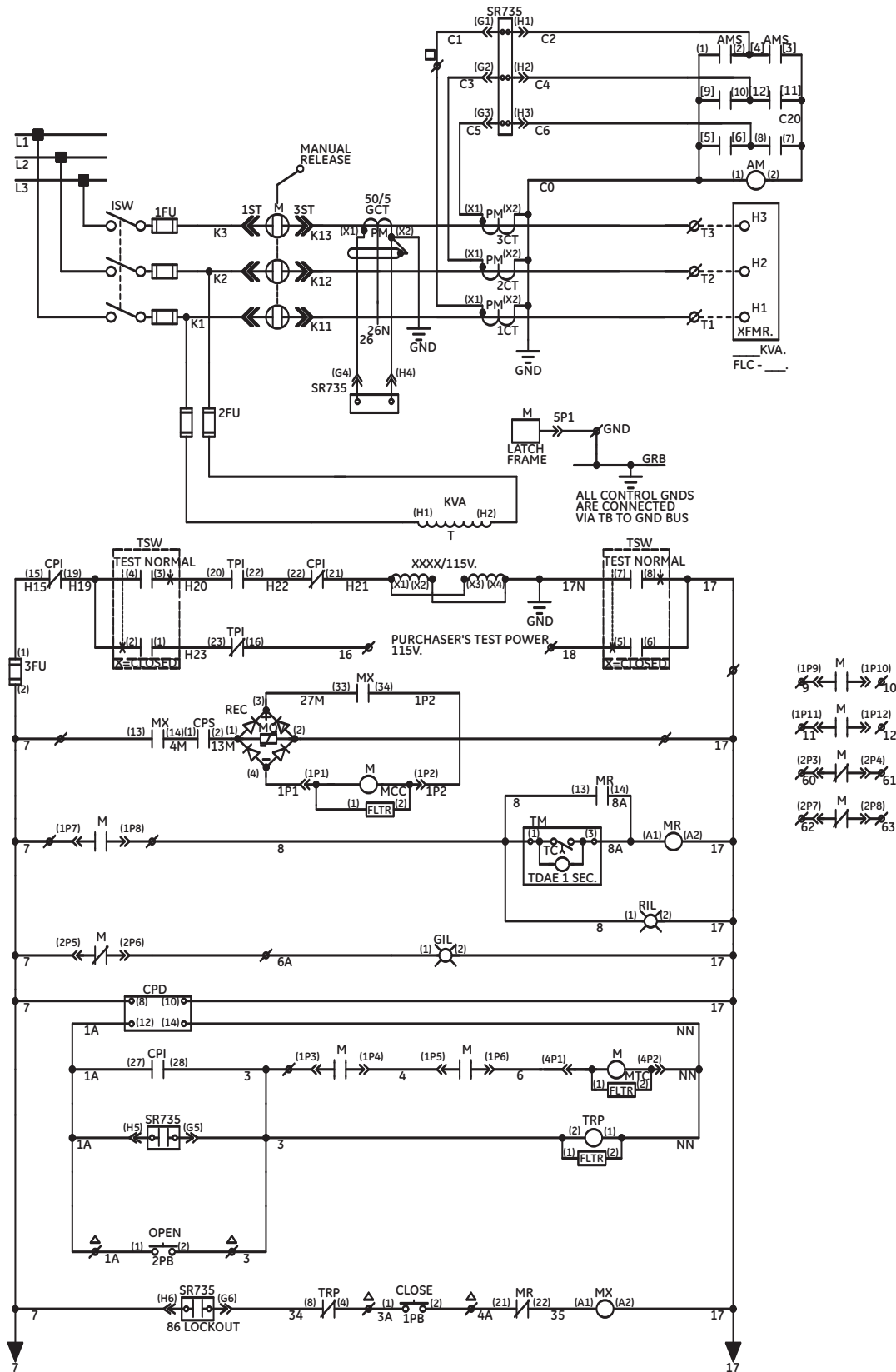

(continued on next page)

GE Limitamp® Medium Voltage Motor Control Typical Elementary Diagrams

400A Drawout Latched FVNR with M735 Relay (Stationary also available)

(continued from previous page)

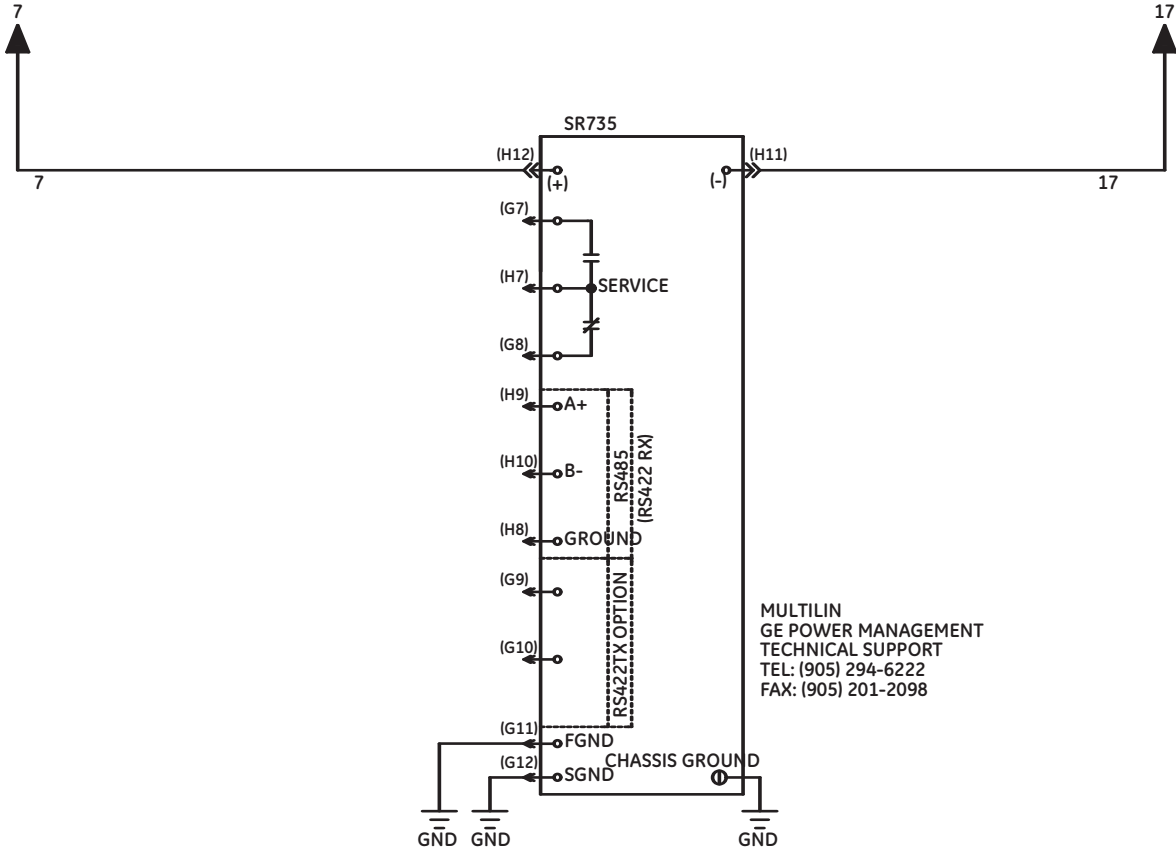

GE Limitamp® Medium Voltage Motor Control Typical Elementary Diagrams

400A Drawout RVSS with M469 Relay (Stationary also available)

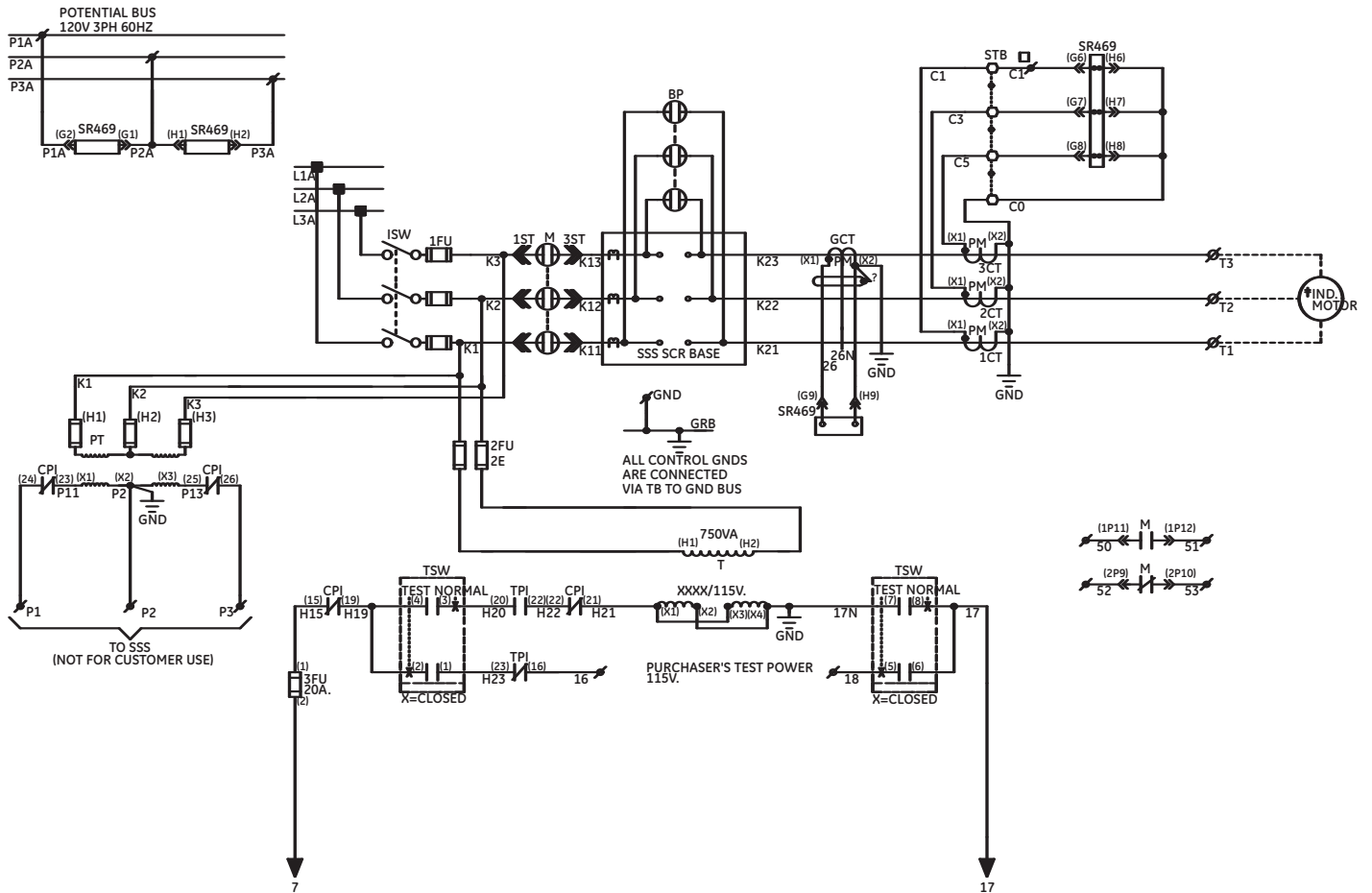

(continued on next page)

GE Limitamp® Medium Voltage Motor Control Typical Elementary Diagrams

400A Drawout RVSS with M469 Relay (Stationary also available)

(continued from previous page)

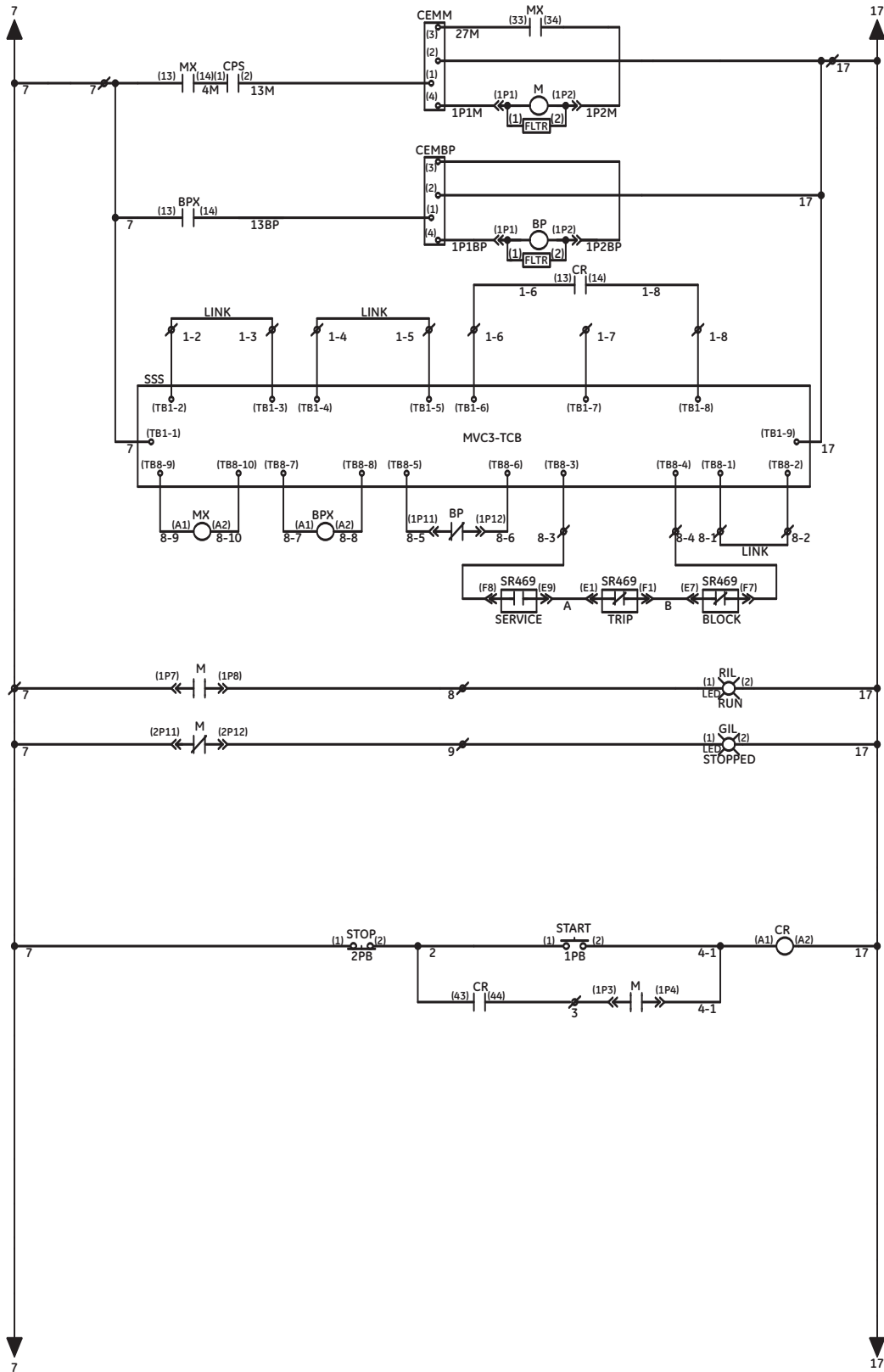

(continued on next page)

GE Limitamp® Medium Voltage Motor Control Typical Elementary Diagrams

400A Drawout RVSS with M469 Relay (Stationary also available)

(continued from previous page)

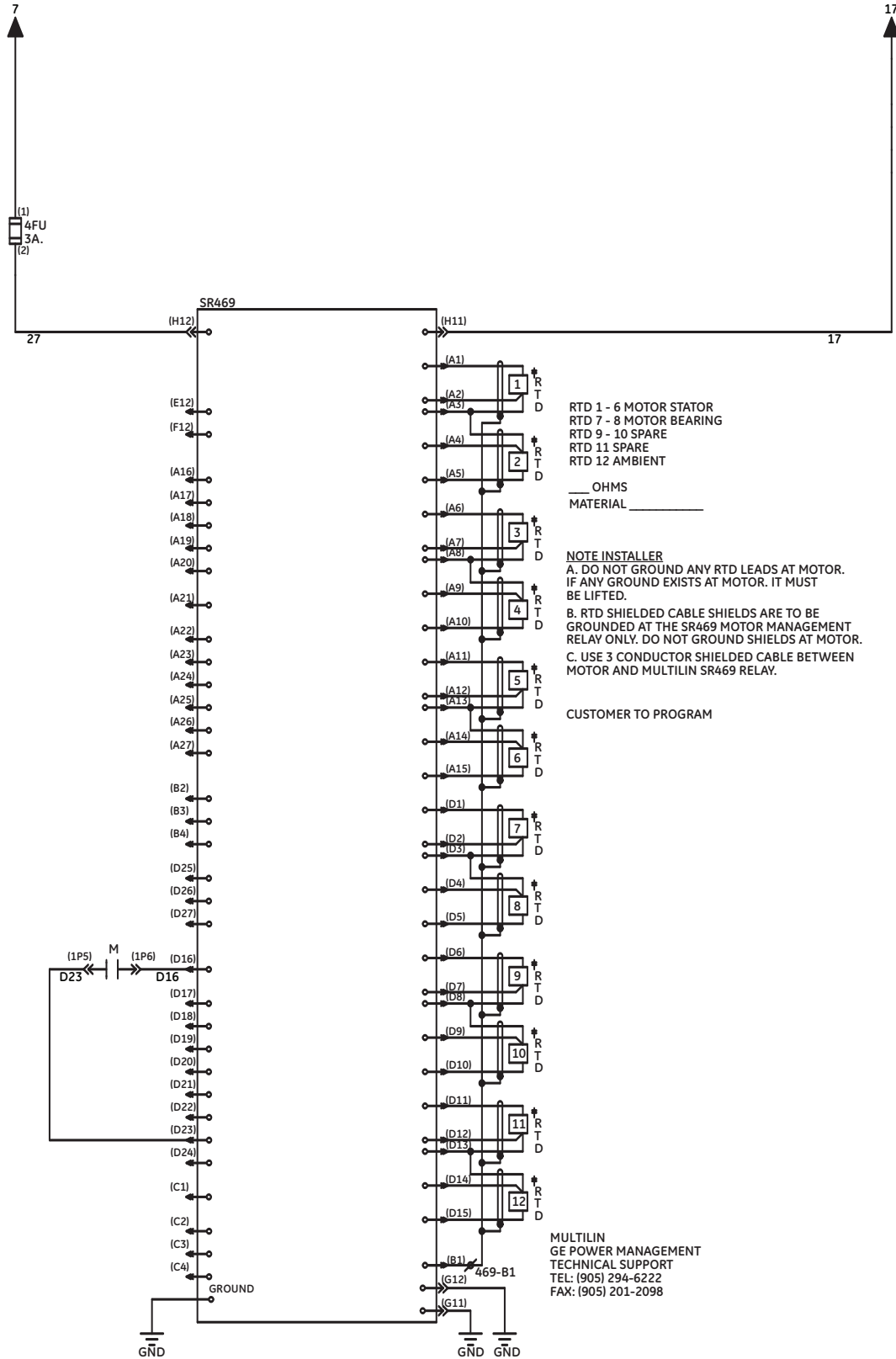

GE Limitamp® Medium Voltage Motor Control Typical Elementary Diagrams

400A Drawout RVAT with M469 Relay (Stationary also available)

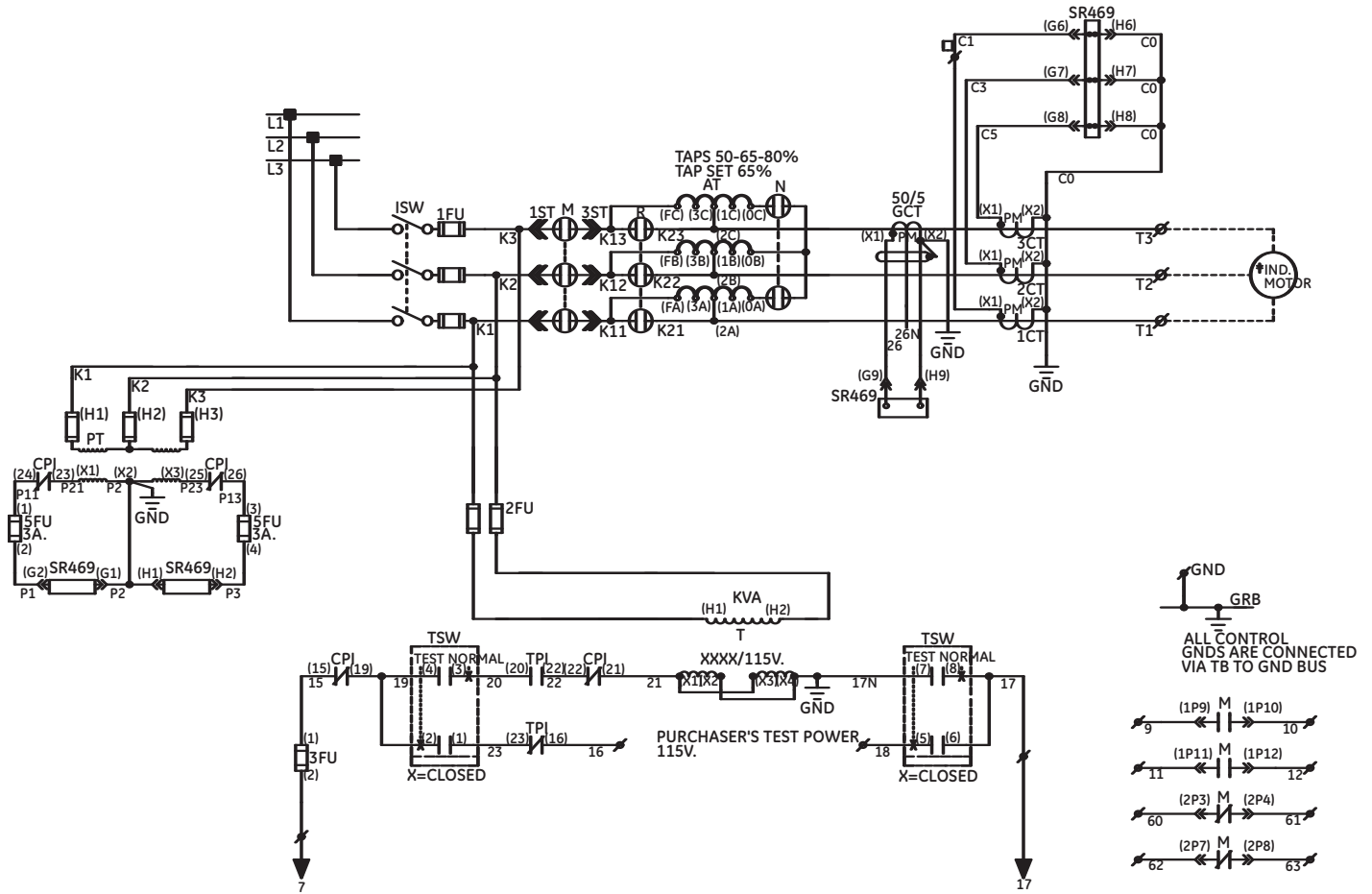

(continued on next page)

GE Limitamp® Medium Voltage Motor Control Typical Elementary Diagrams

400A Drawout RVAT with M469 Relay (Stationary also available)

(continued from previous page)

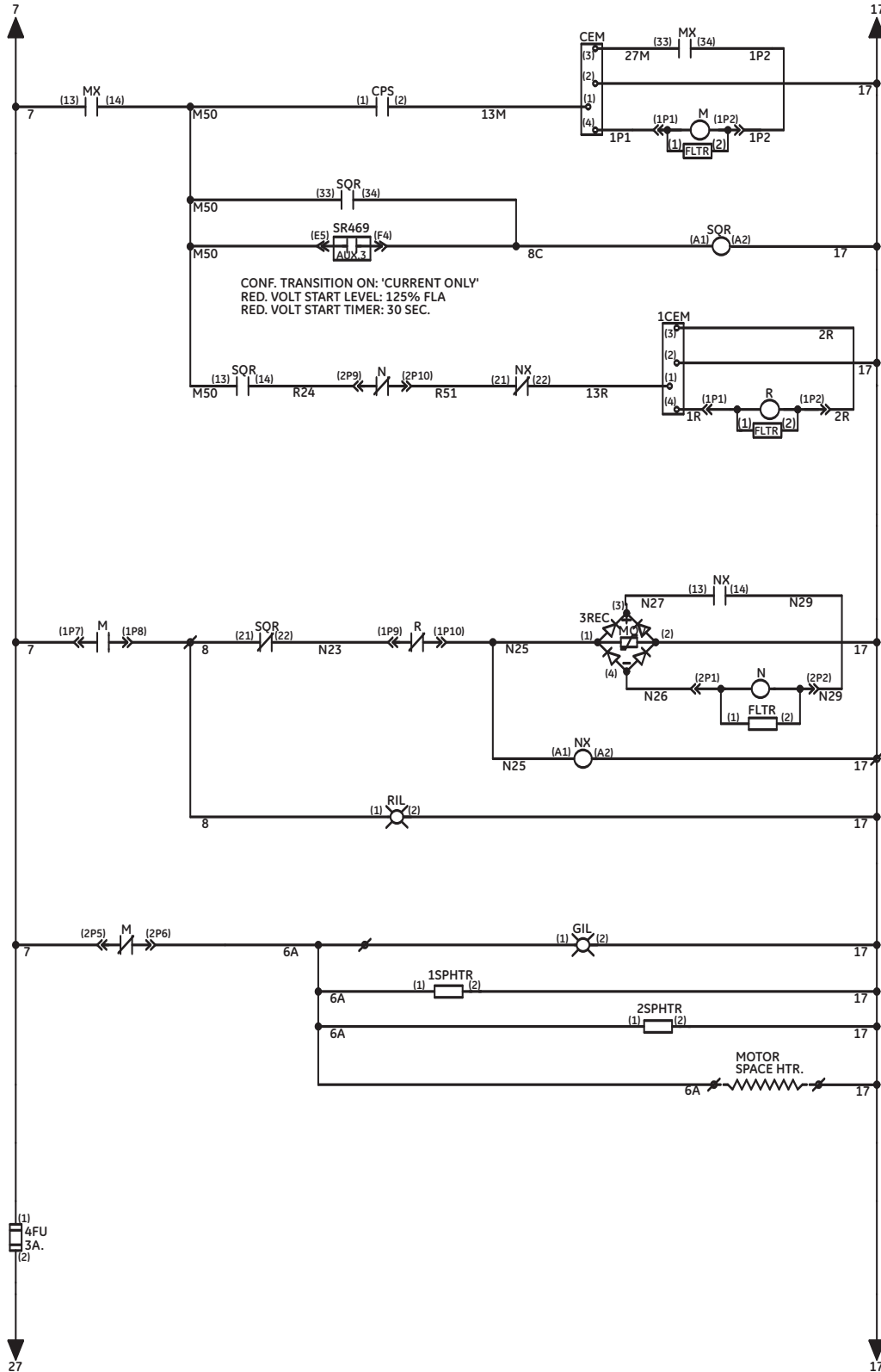

(continued on next page)

GE Limitamp® Medium Voltage Motor Control

Typical Elementary Diagrams

400A Drawout RVAT with M469 Relay (Stationary also available)

(continued from previous page)

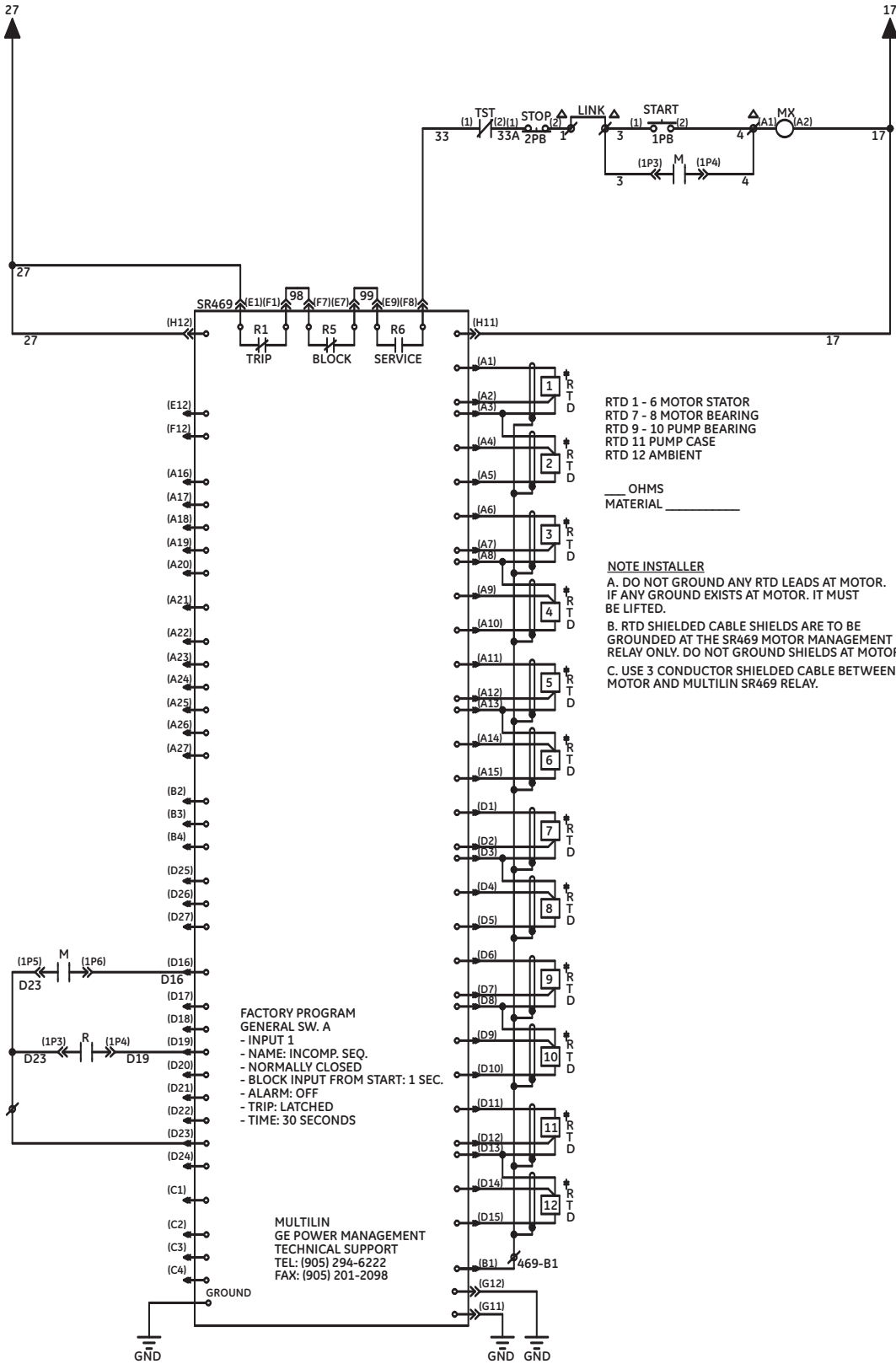

GE Limitamp® Medium Voltage Motor Control Typical Elementary Diagrams

400A Drawout RVPR with M469 Relay (Stationary also available)

(continued from previous page)

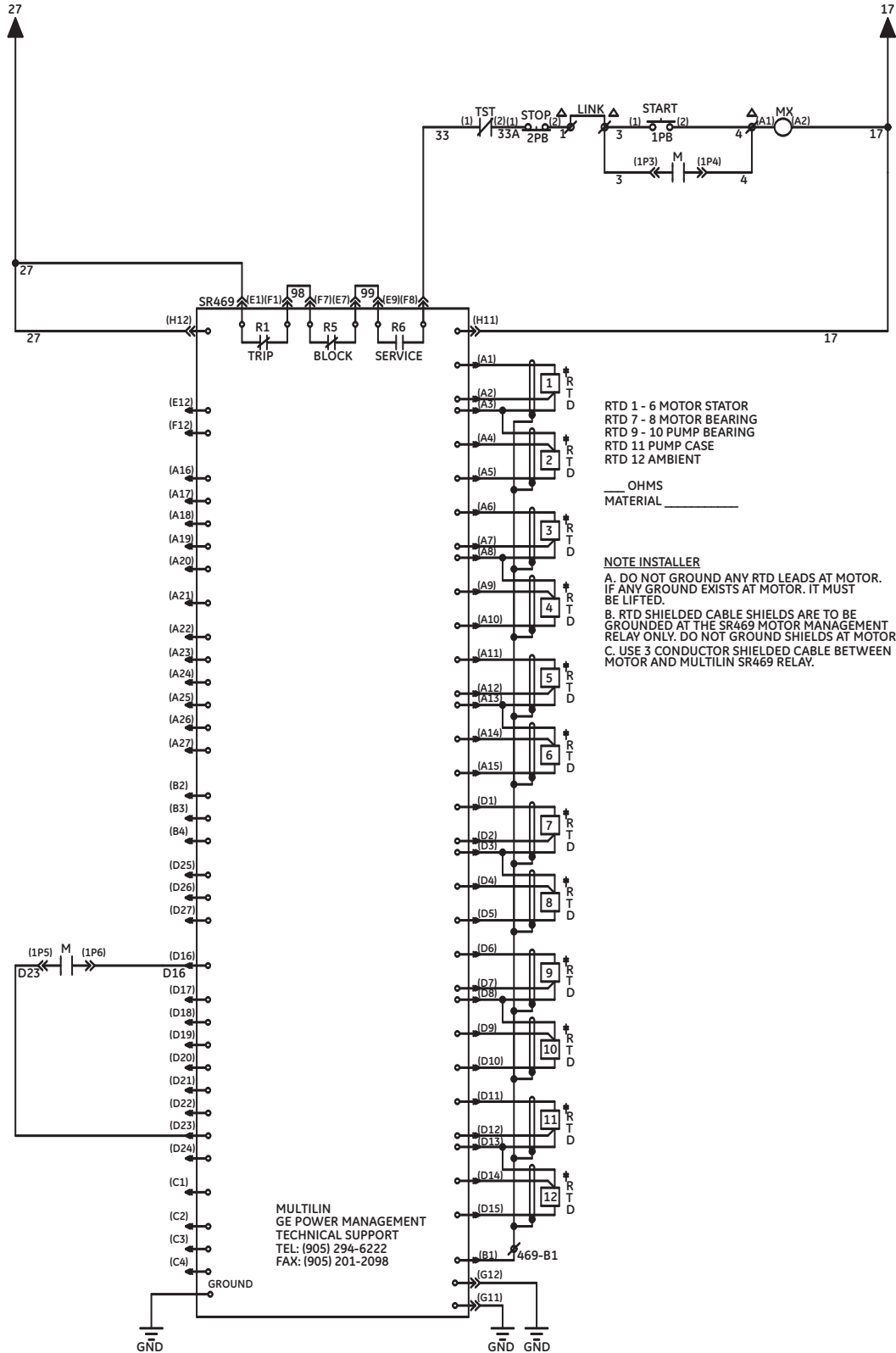

GE Limitamp® Medium Voltage Motor Control Typical Elementary Diagrams

400A Stationary Brush FVNR with SFC, M469 Relay (Drawout also available)

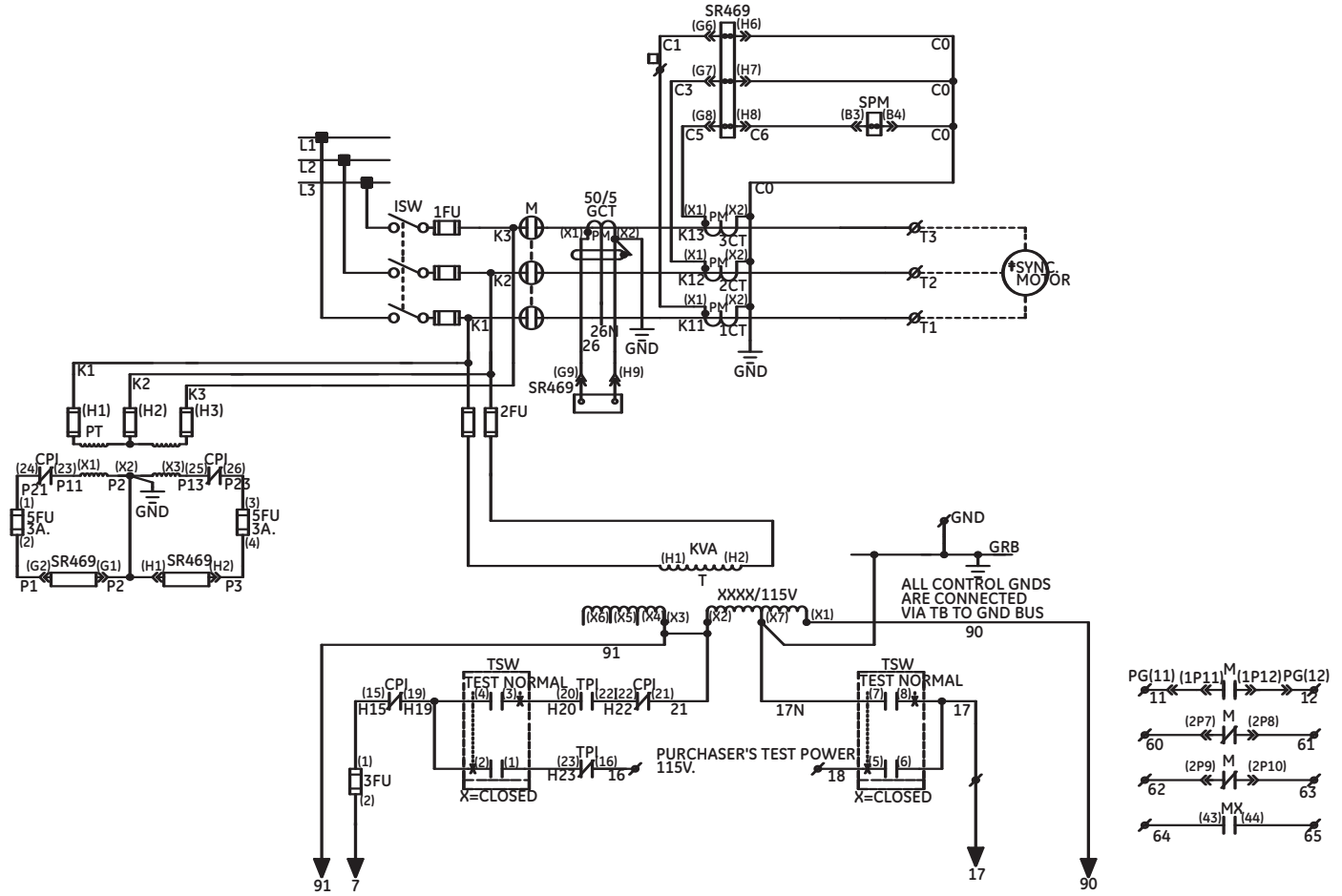

(continued on next page)

GE Limitamp® Medium Voltage Motor Control Typical Elementary Diagrams

400A Stationary Brush FVNR with SFC, M469 Relay (Drawout also available)

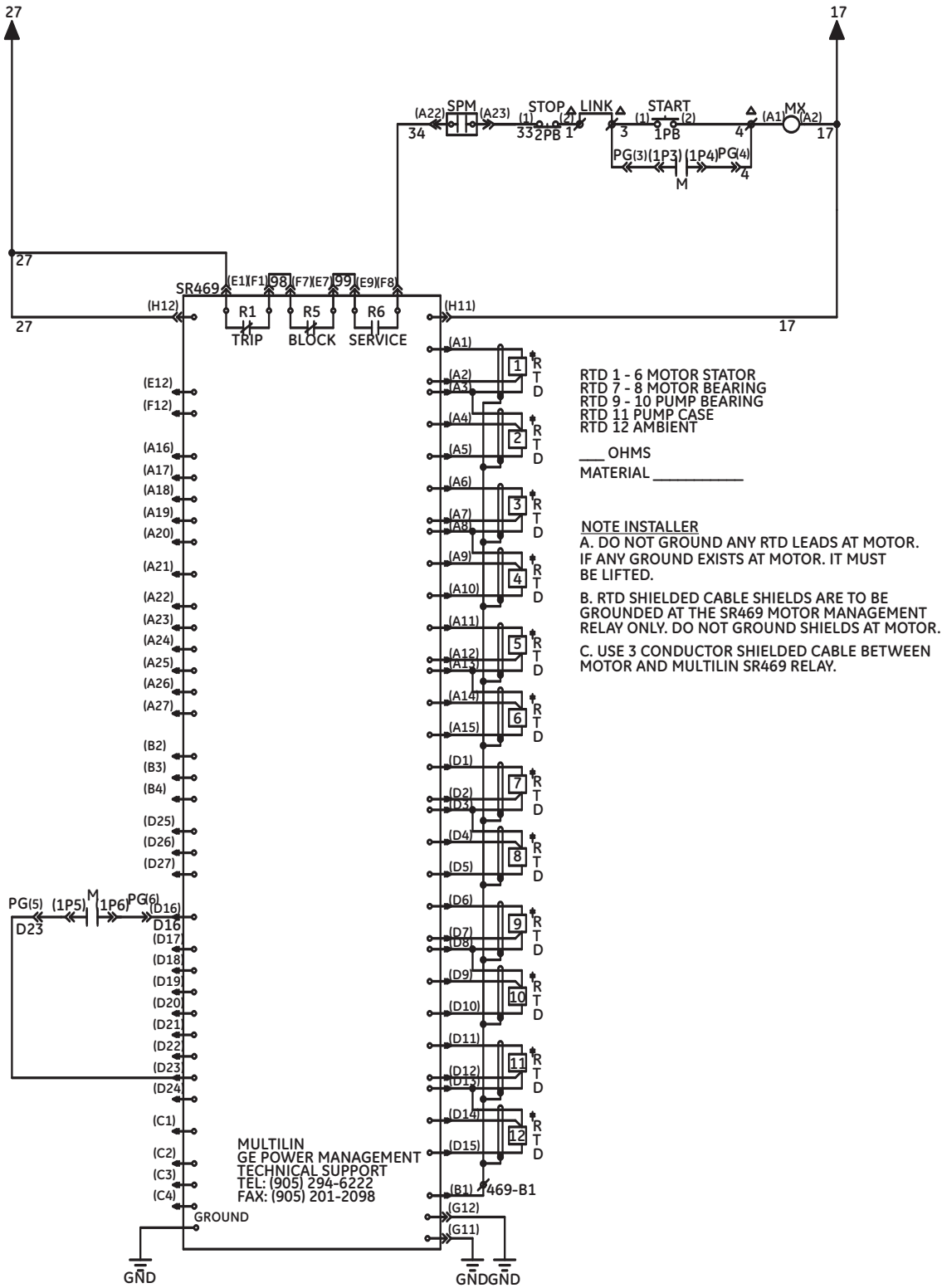

GE Limitamp® Medium Voltage Motor Control Typical Elementary Diagrams

400A Stationary Brushless FVNR with M469 Relay (Drawout also available)

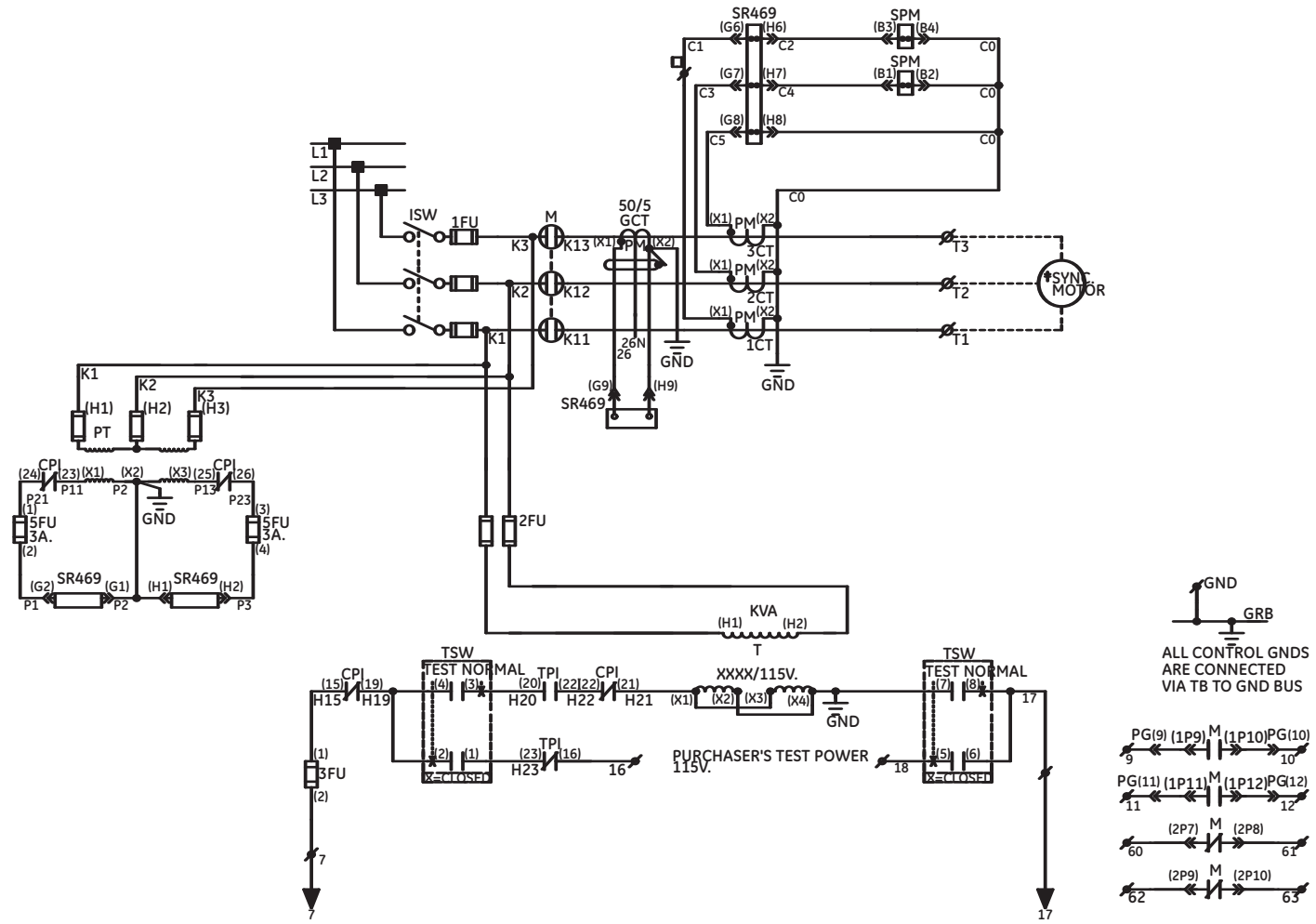

(continued on next page)

GE Limitamp® Medium Voltage Motor Control Typical Elementary Diagrams

400A Stationary Brushless FVNR with M469 Relay (Drawout also available)

(continued from previous page)

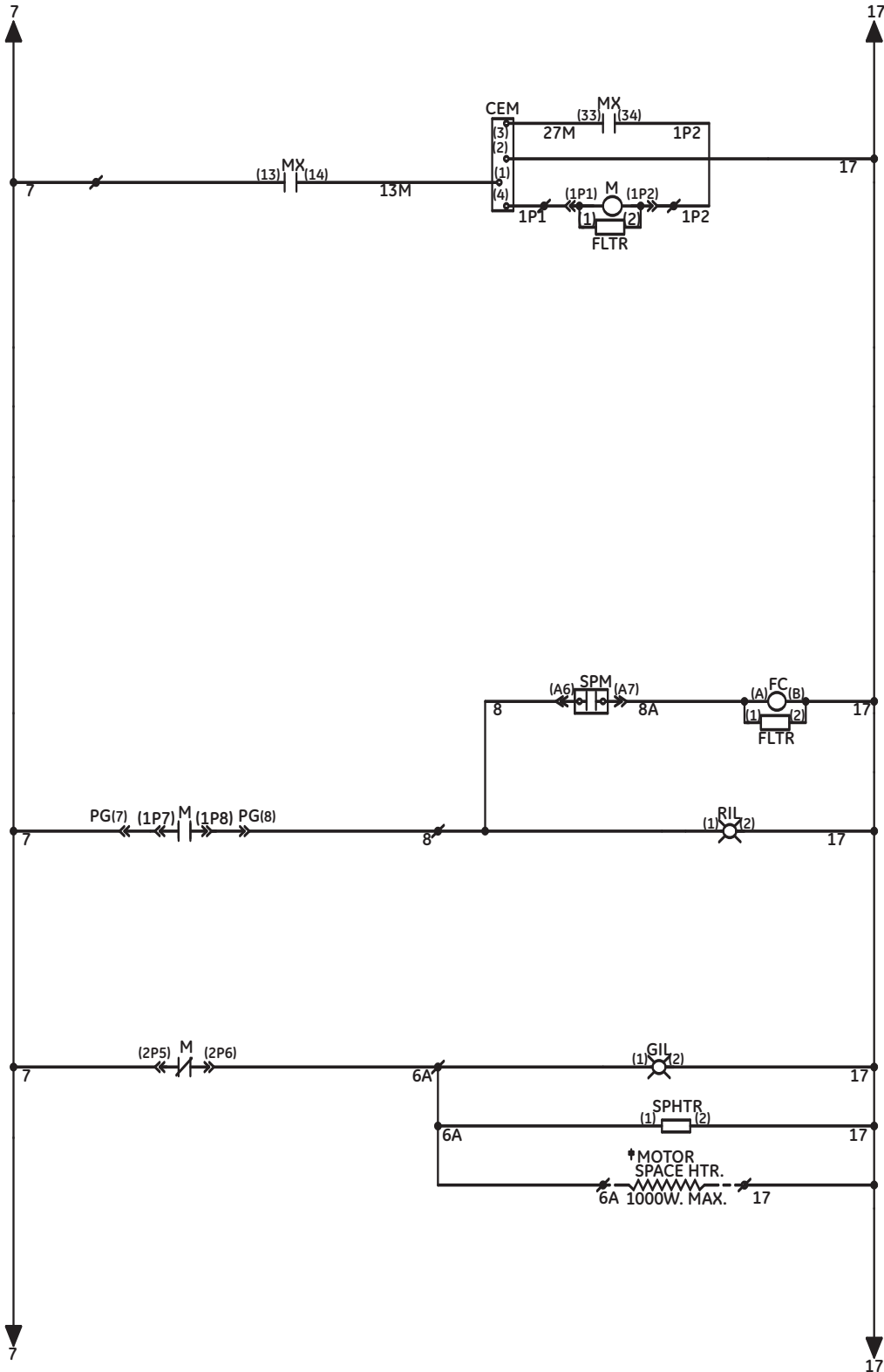

GE Limitamp® Medium Voltage Motor Control Typical Elementary Diagrams

400A Stationary Brushless FVNR with M469 Relay (Drawout also available)

(continued from previous page)

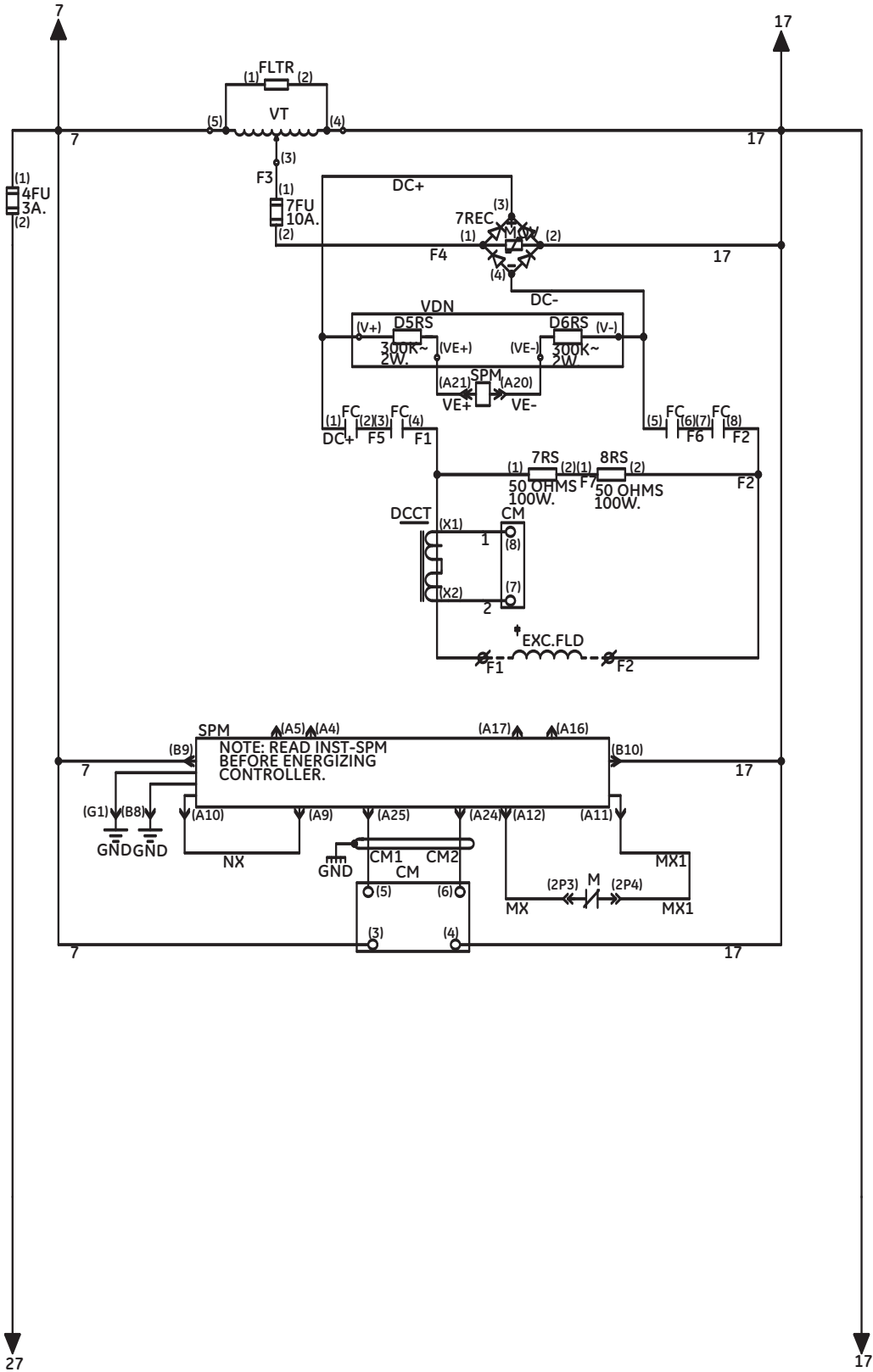

(continued on next page)

GE Limitamp® Medium Voltage Motor Control Typical Elementary Diagrams

400A Stationary Brushless FVNR with M469 Relay (Drawout also available)

(continued from previous page)

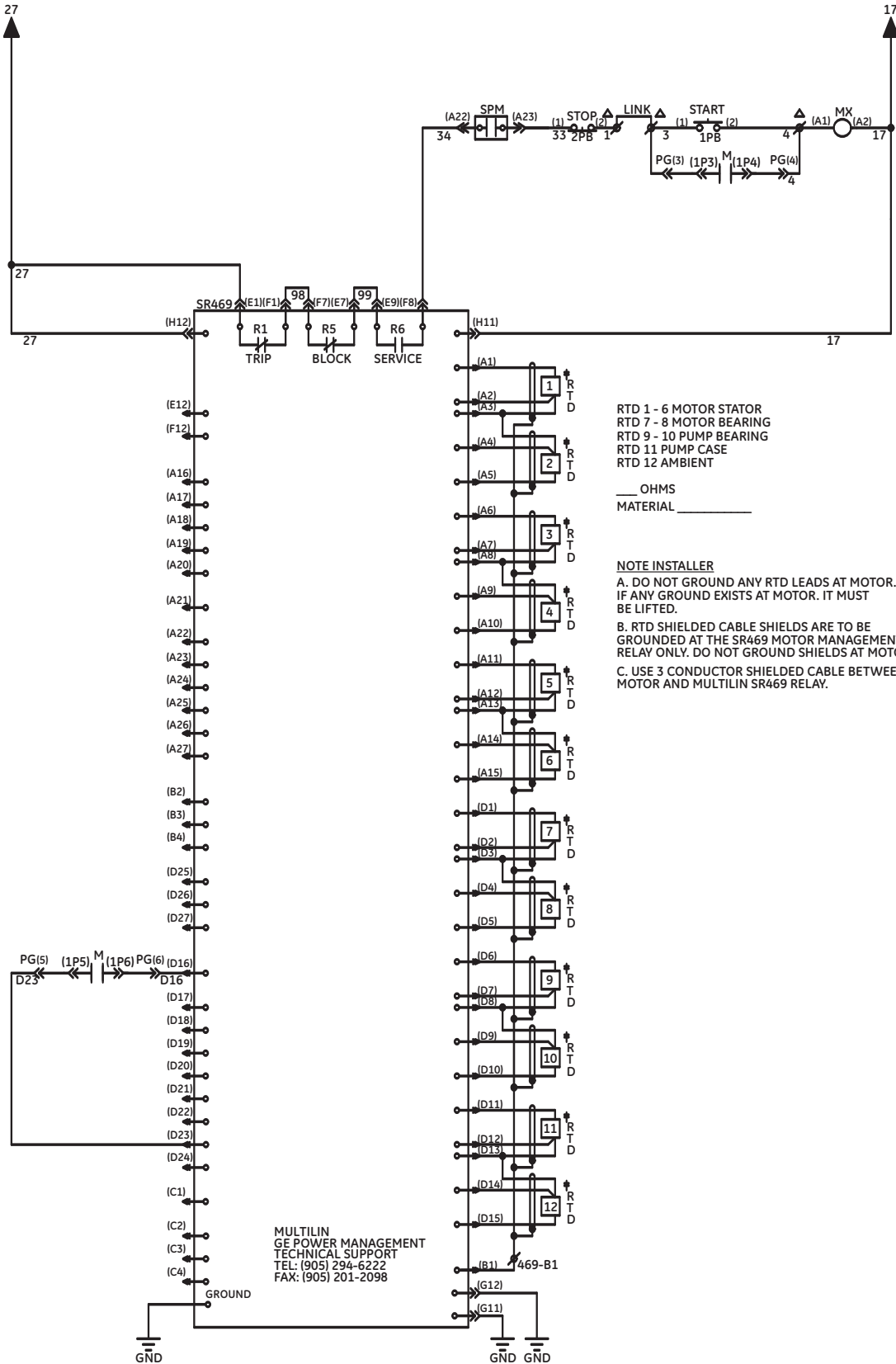

GE Limitamp® Medium Voltage Motor Control Typical Elementary Diagrams

400A Drawout Brush Sync with VFC, M469 Relay (Stationary also available)

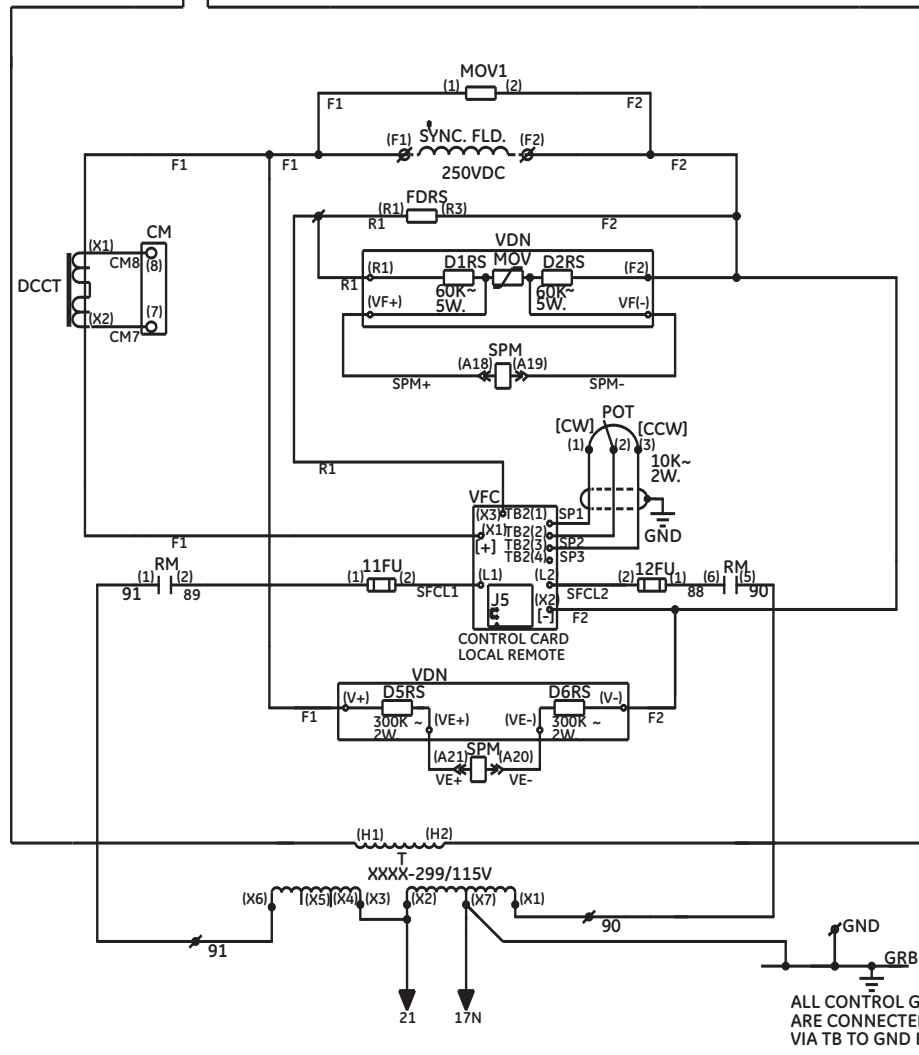
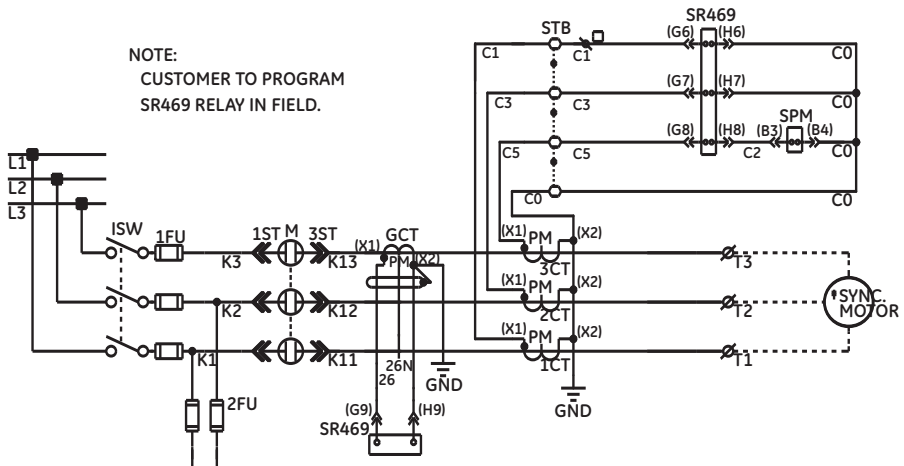

(continued on next page)

GE Limitamp® Medium Voltage Motor Control Typical Elementary Diagrams

400A Drawout Brush Sync with VFC, M469 Relay (Stationary also available)

(continued from previous page)

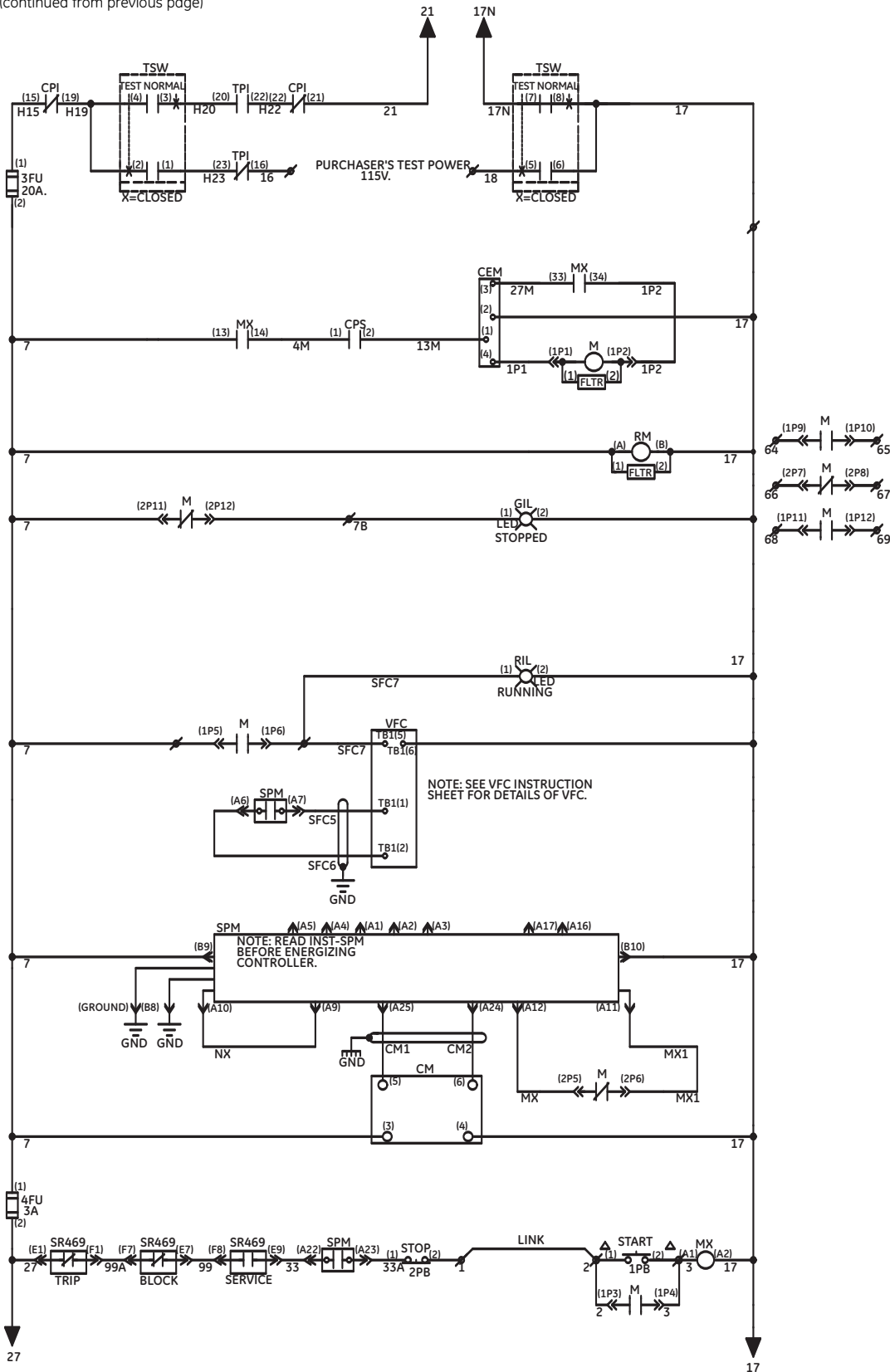

(continued on next page)

GE Limitamp® Medium Voltage Motor Control Typical Elementary Diagrams

400A Drawout Brush Sync with VFC, M469 Relay (Stationary also available)

(continued from previous page)

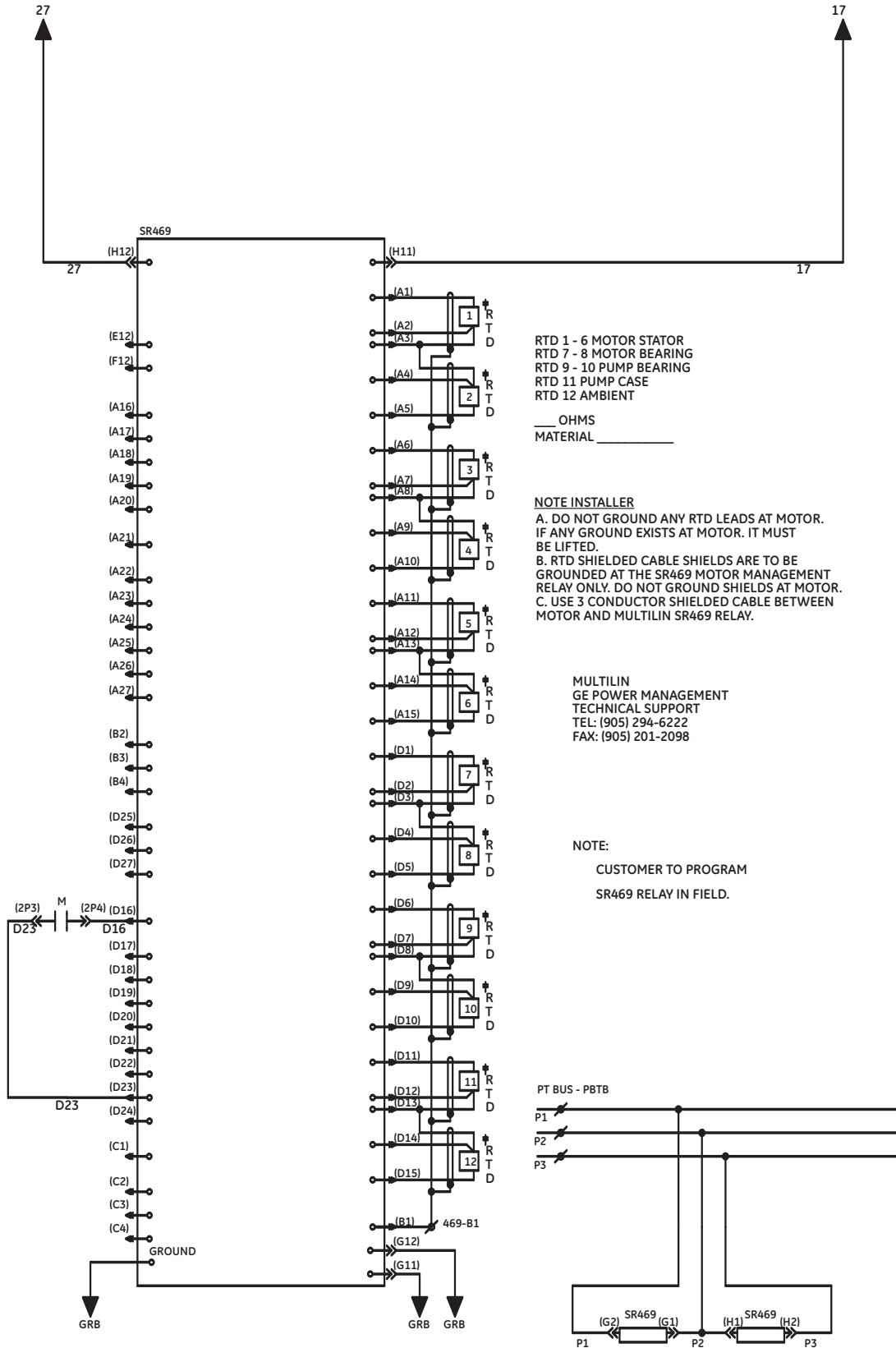

GE Limitamp® Medium Voltage Motor Control Typical Elementary Diagrams

400A Stationary FVR with M469 Relay (Drawout also available)

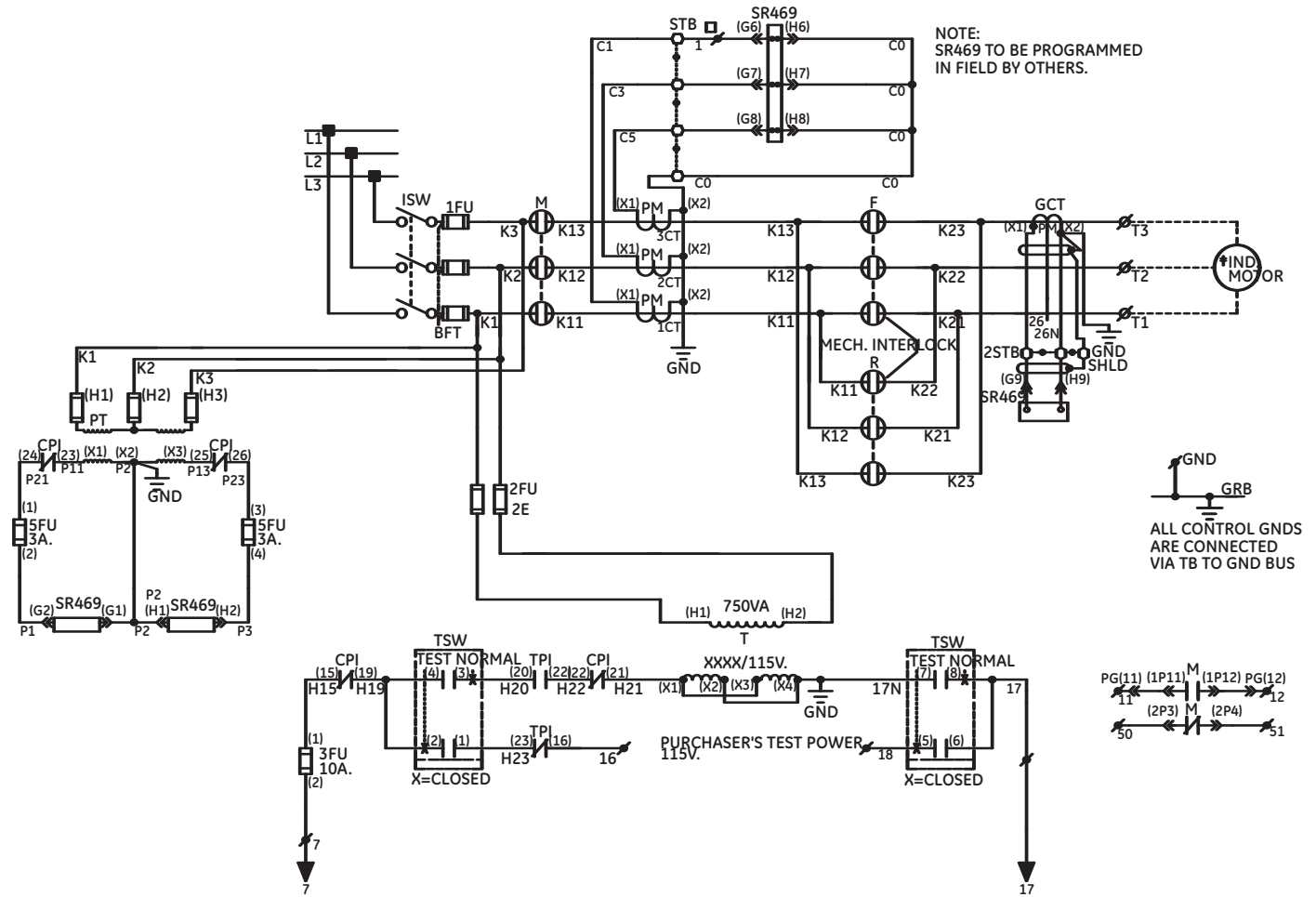

(continued on next page)

GE Limitamp® Medium Voltage Motor Control Typical Elementary Diagrams

400A Stationary FVR with M469 Relay (Drawout also available)

(continued from previous page)

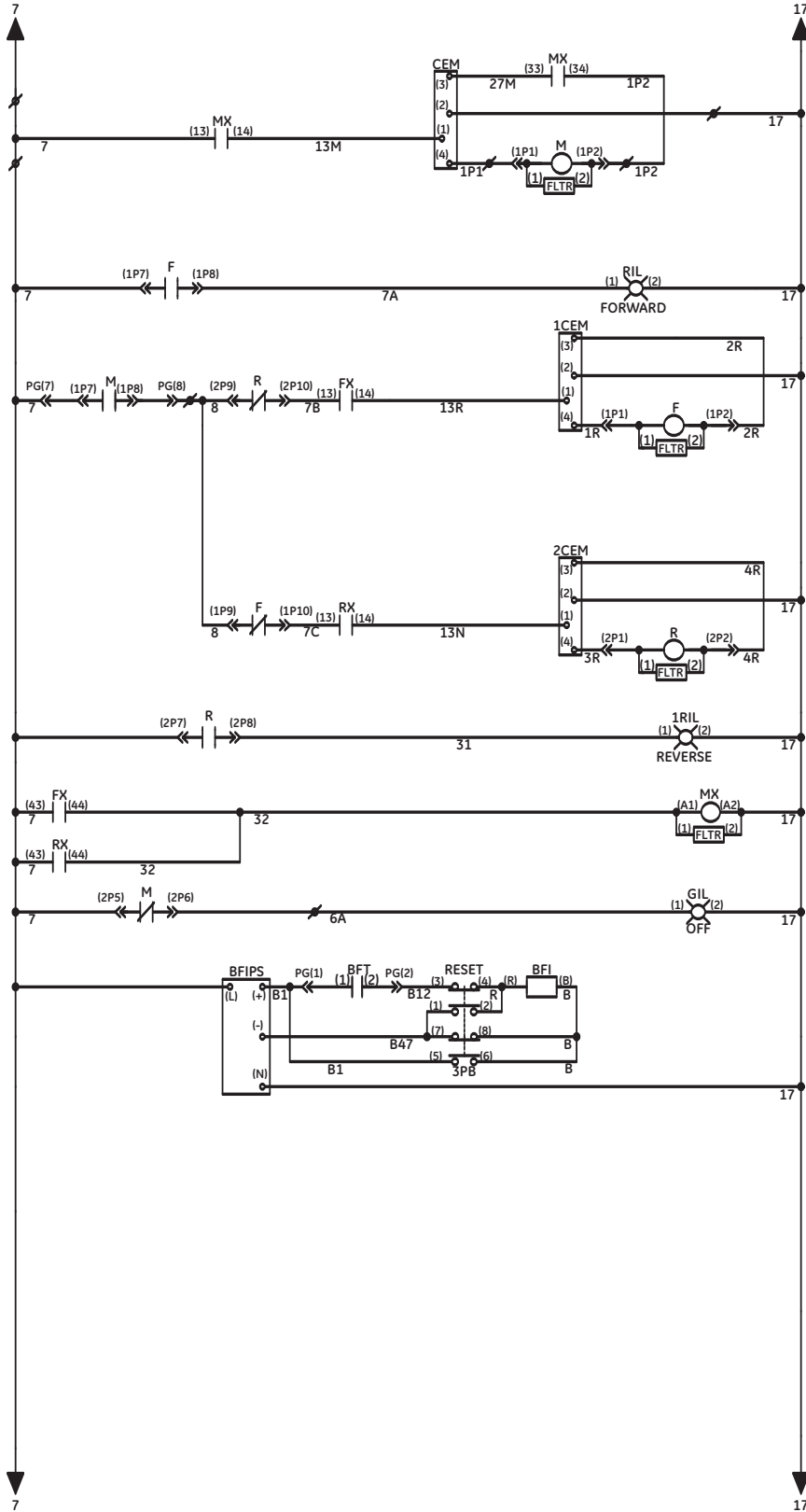

(continued on next page)

GE Limitamp® Medium Voltage Motor Control Typical Elementary Diagrams

400A Stationary FVR with M469 Relay (Drawout also available)

(continued from previous page)

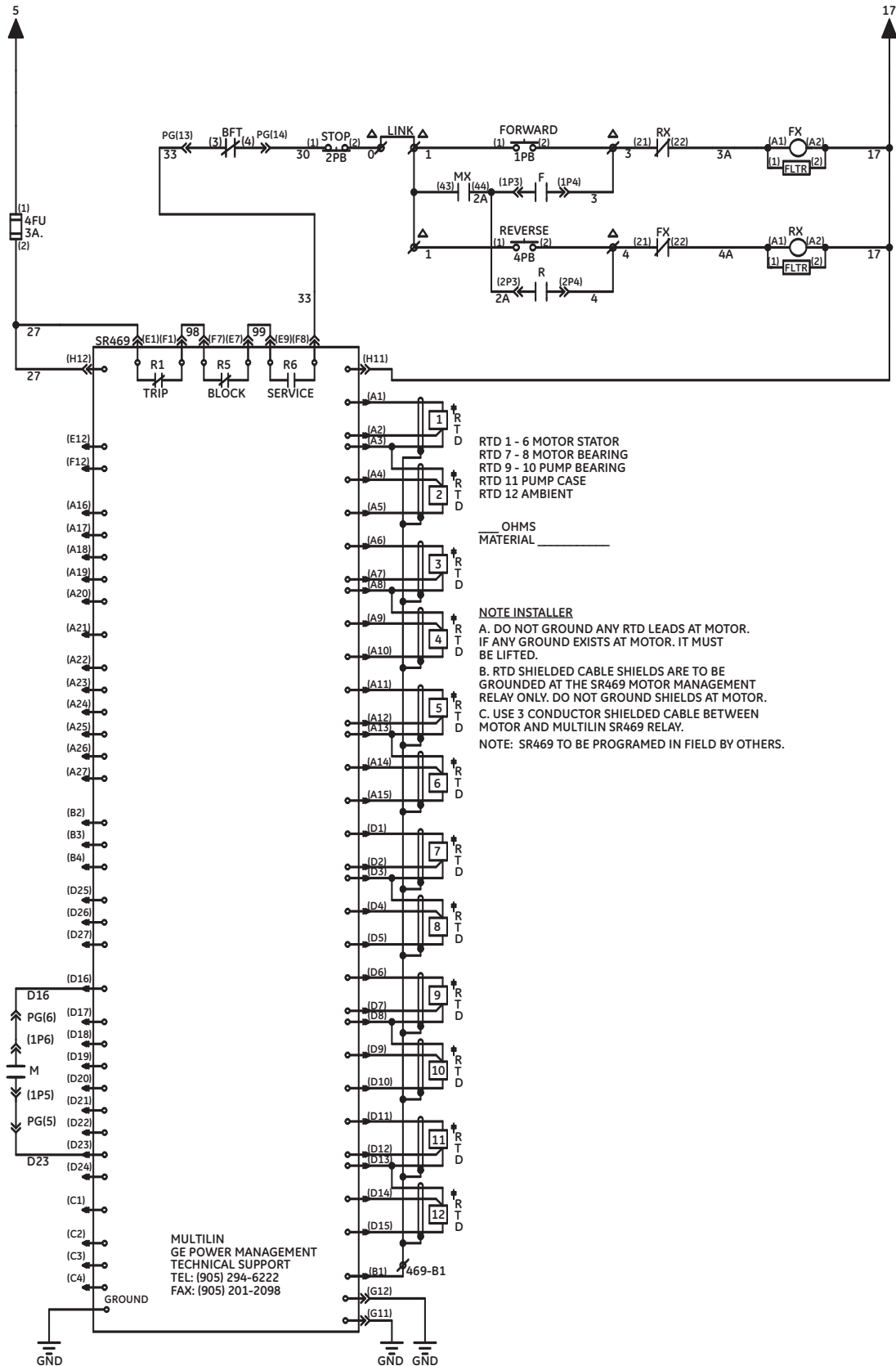

GE Limitamp® Medium Voltage Motor Control Typical Elementary Diagrams

800A Drawout FVNR with M469 Relay (Stationary also available)

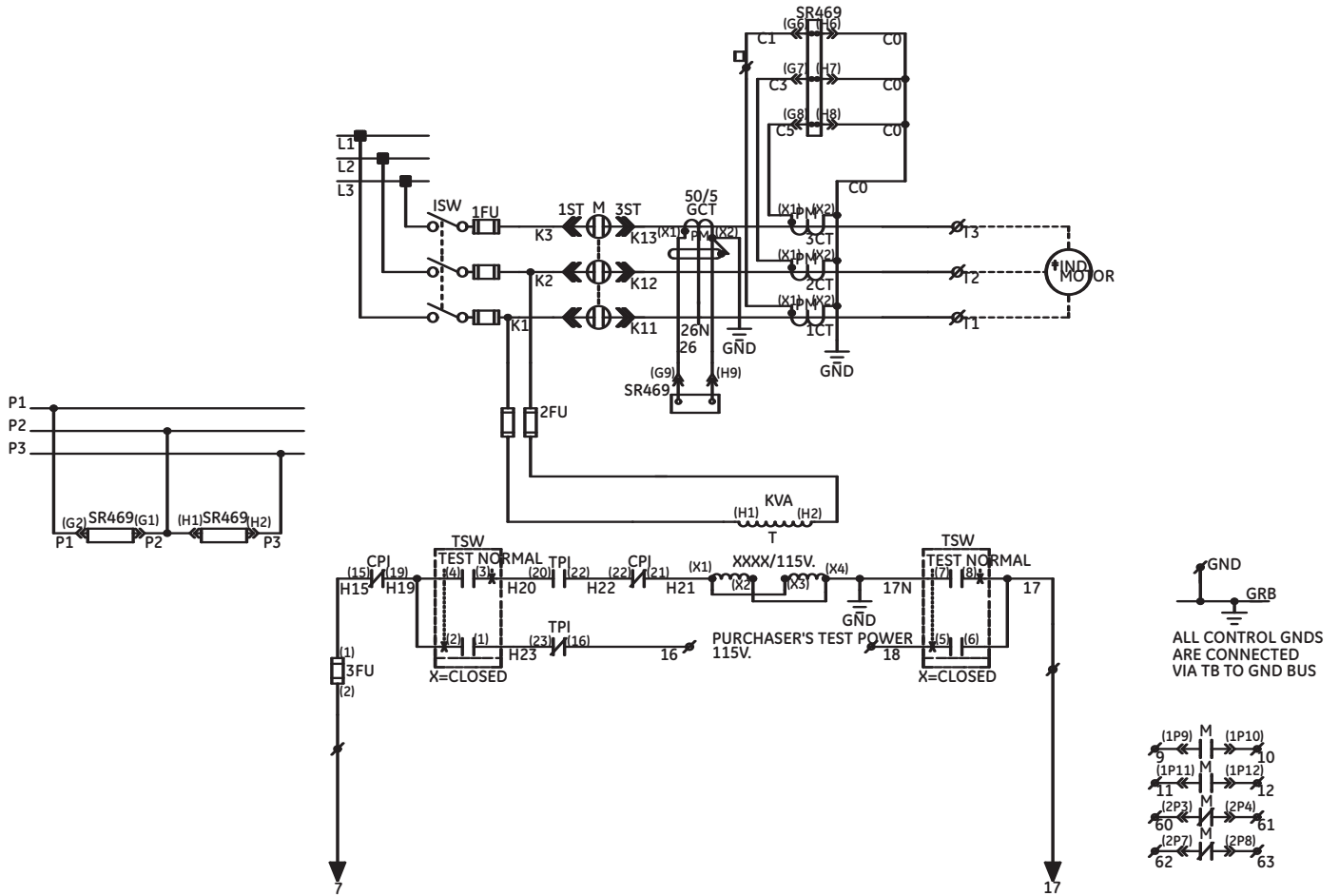

(continued on next page)

GE Limitamp® Medium Voltage Motor Control Typical Elementary Diagrams

800A Drawout FVNR with M469 Relay (Stationary also available)

(continued from previous page)

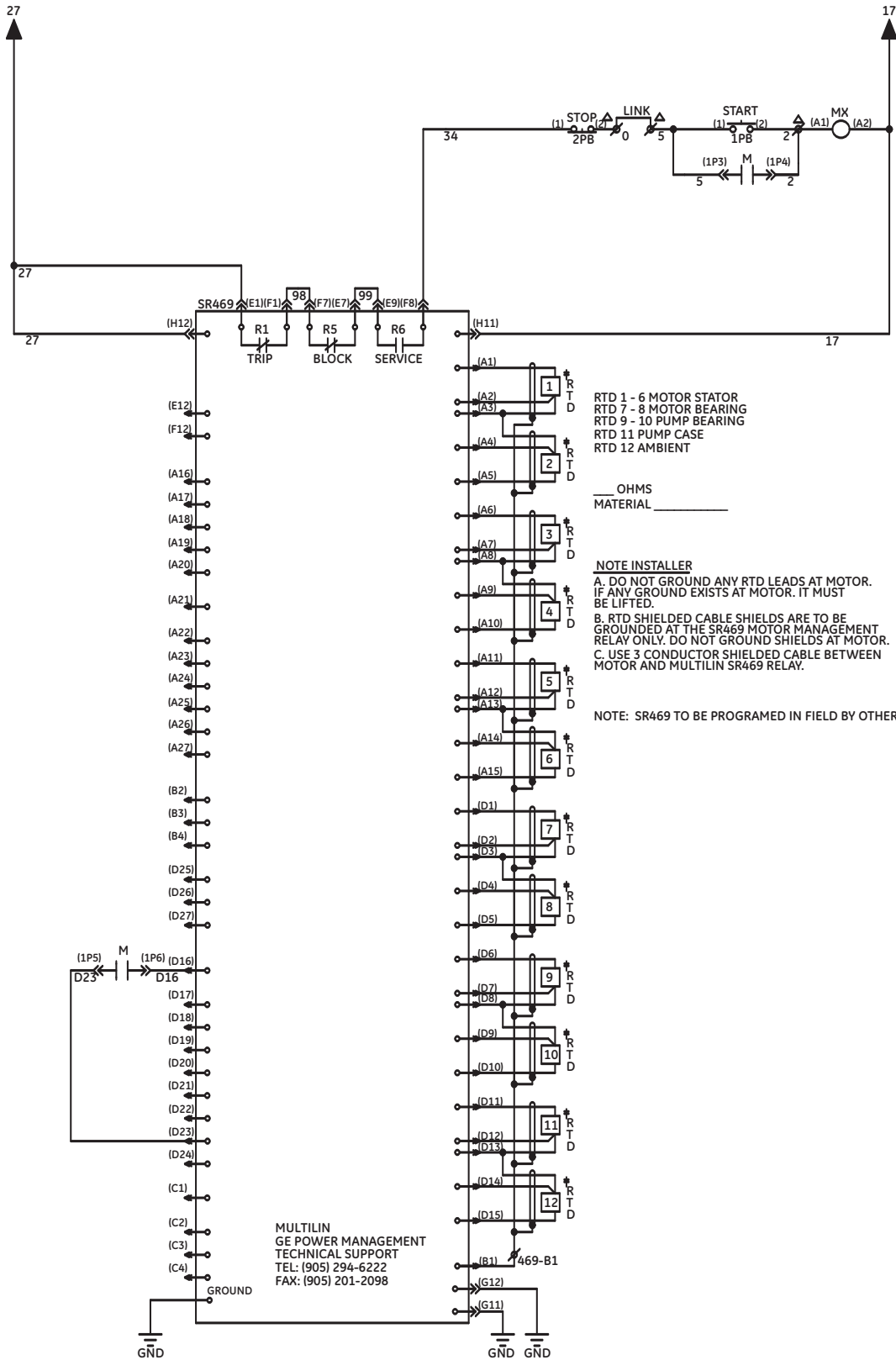

(continued on next page)

GE Limitamp® Medium Voltage Motor Control Typical Elementary Diagrams

800A Drawout Latched FVNR with M735 Relay (Stationary also available)

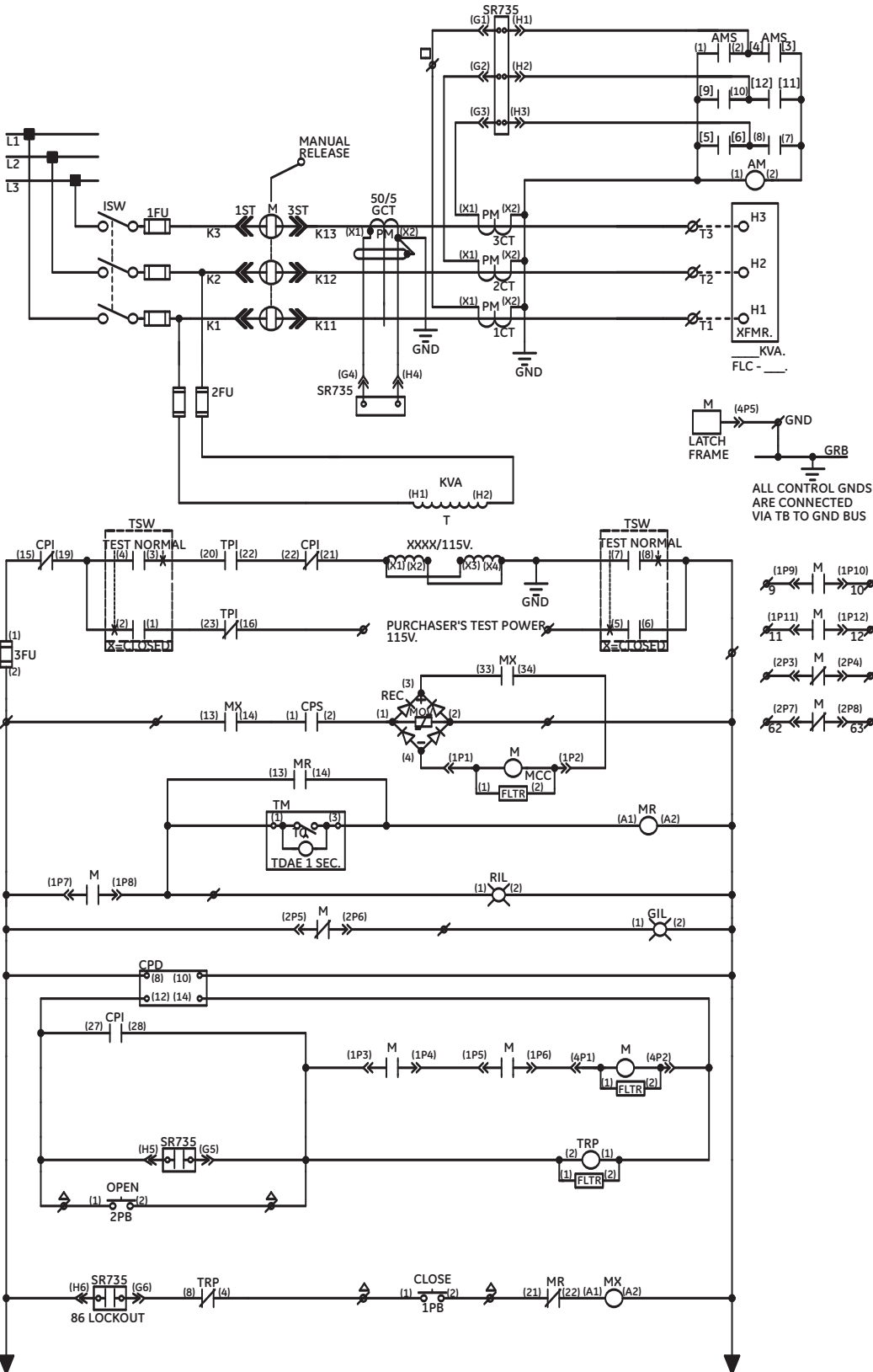

(continued on next page)

GE Limitamp® Medium Voltage Motor Control Typical Elementary Diagrams

800A Drawout Latched FVNR with M735 Relay (Stationary also available)

(continued from previous page)

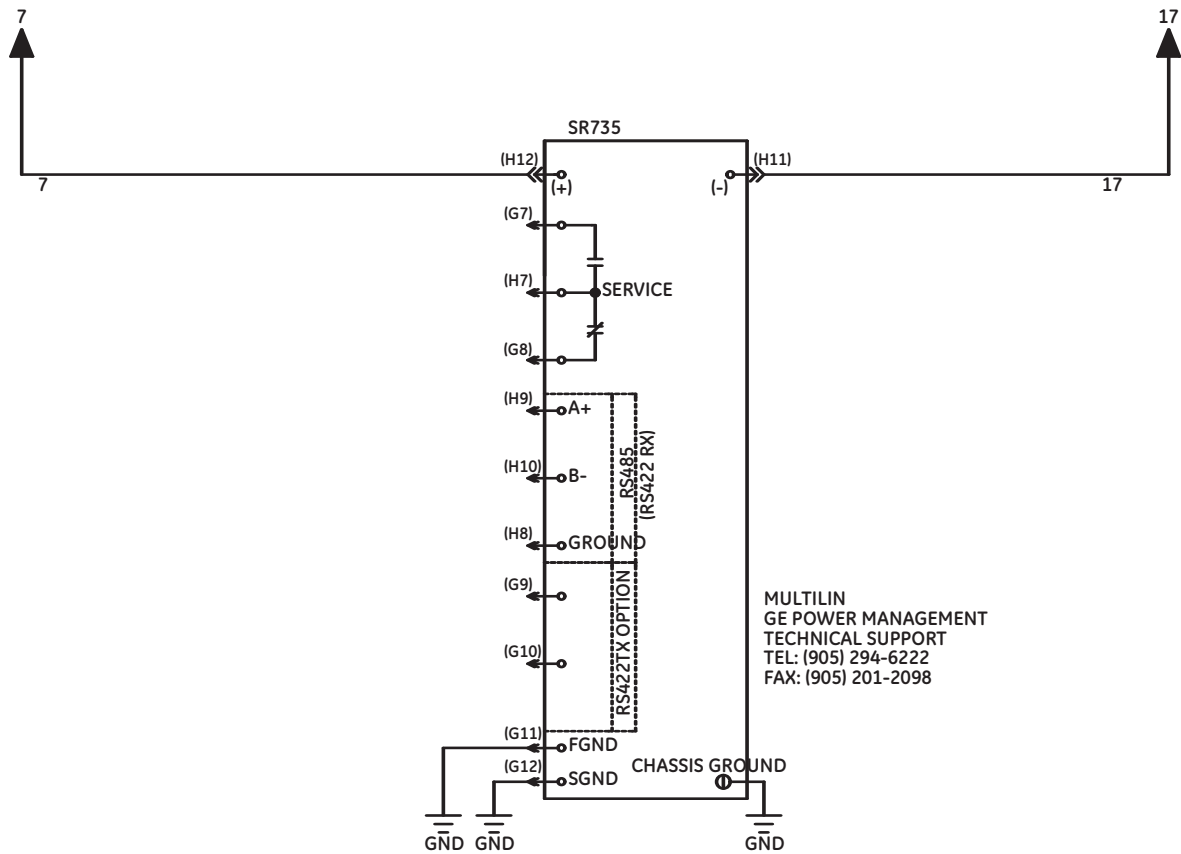

GE Limitamp® Medium Voltage Motor Control Typical Elementary Diagrams

800A Stationary RVSS with M469 Relay (Drawout also available)

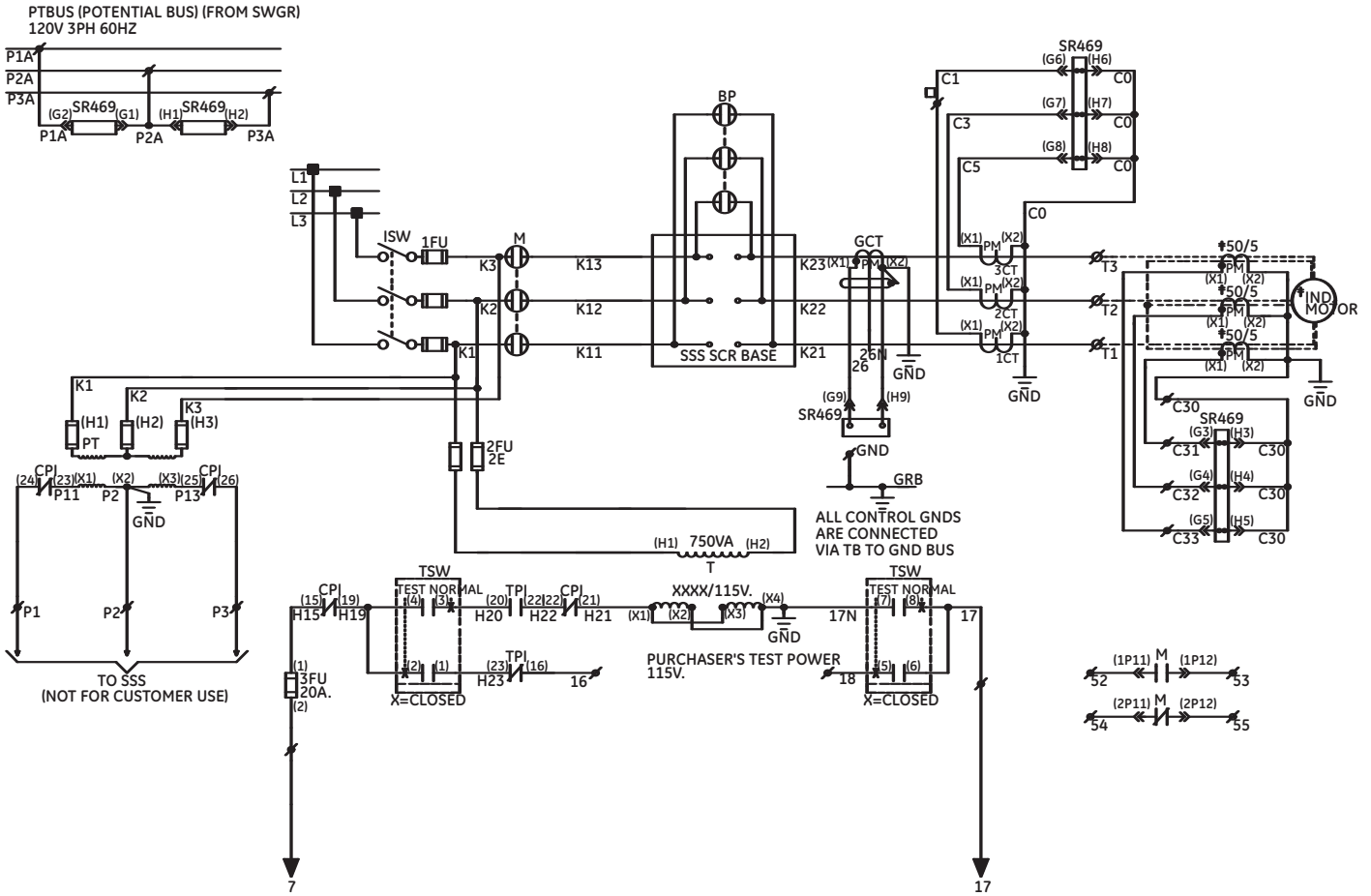

(continued on next page)

GE Limitamp® Medium Voltage Motor Control Typical Elementary Diagrams

800A Stationary RVSS with M469 Relay (Drawout also available)

(continued from previous page)

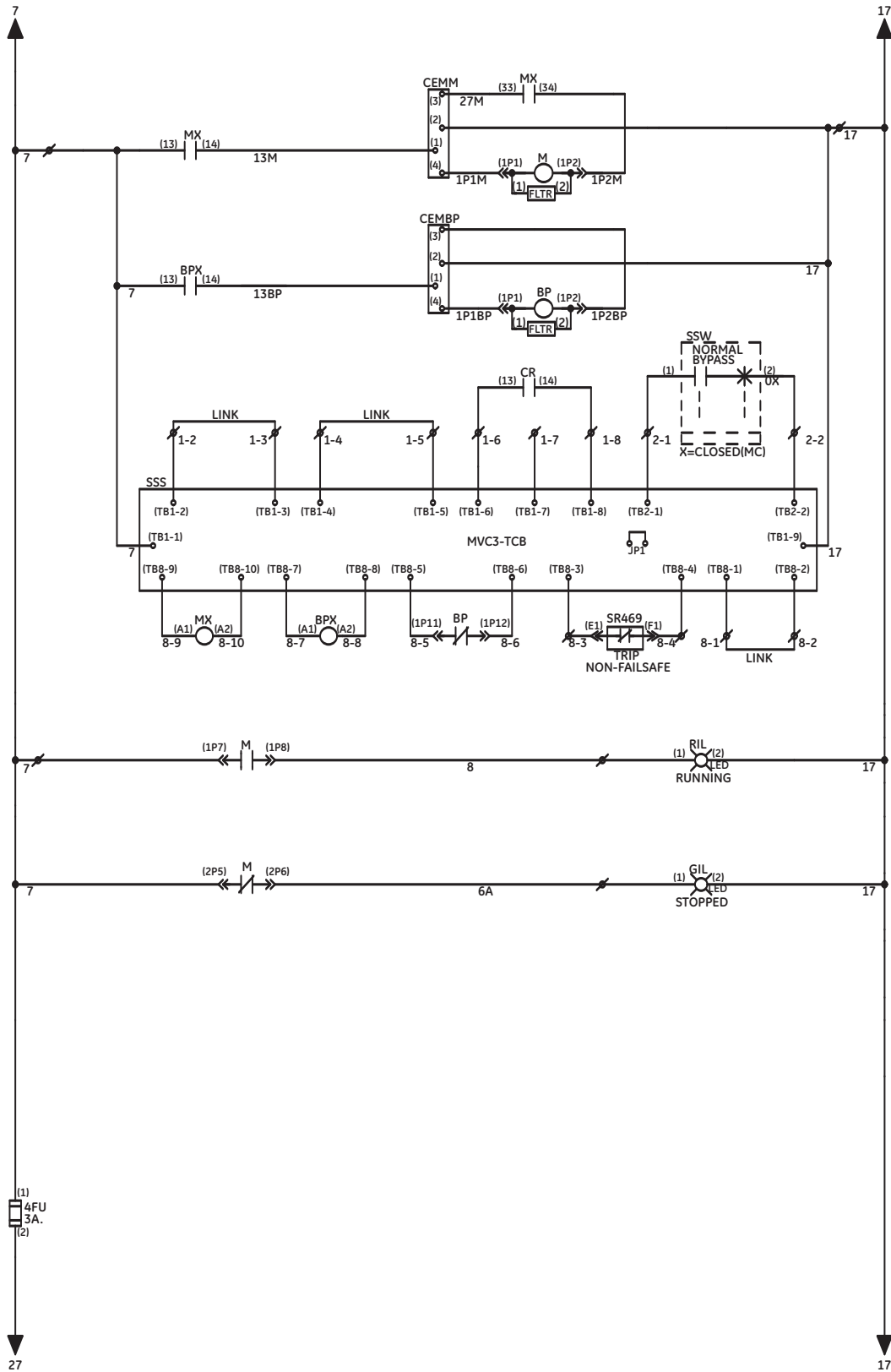

(continued on next page)

GE Limitamp® Medium Voltage Motor Control Typical Elementary Diagrams

800A Stationary RVSS with M469 Relay (Drawout also available)

(continued from previous page)

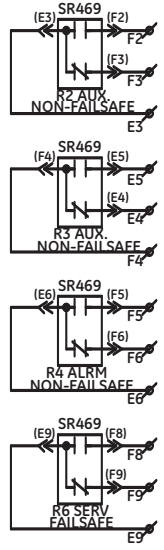
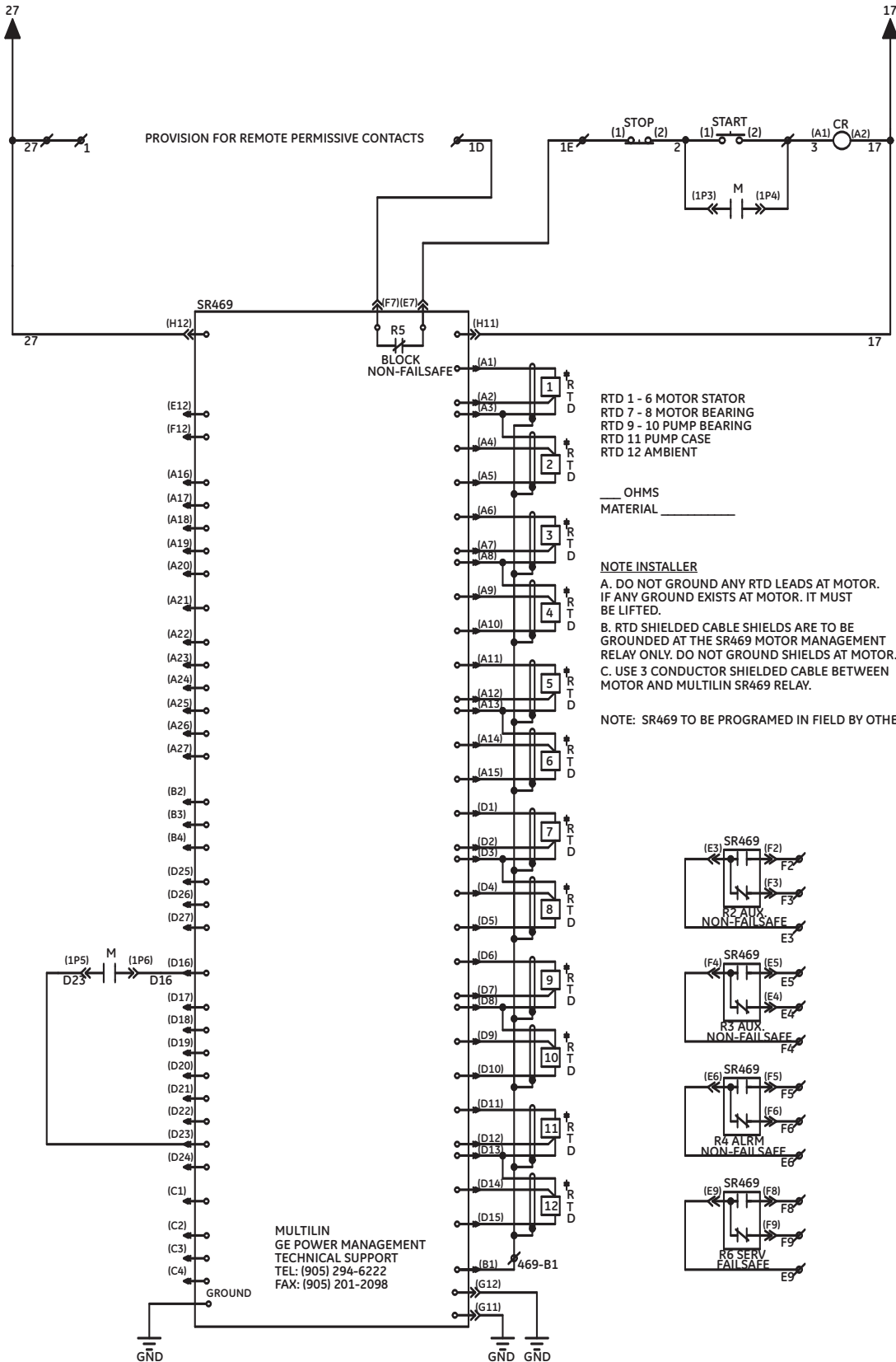

GE Limitamp® Medium Voltage Motor Control Typical Elementary Diagrams

800A Drawout RVAT with M469 Relay (Stationary also available)

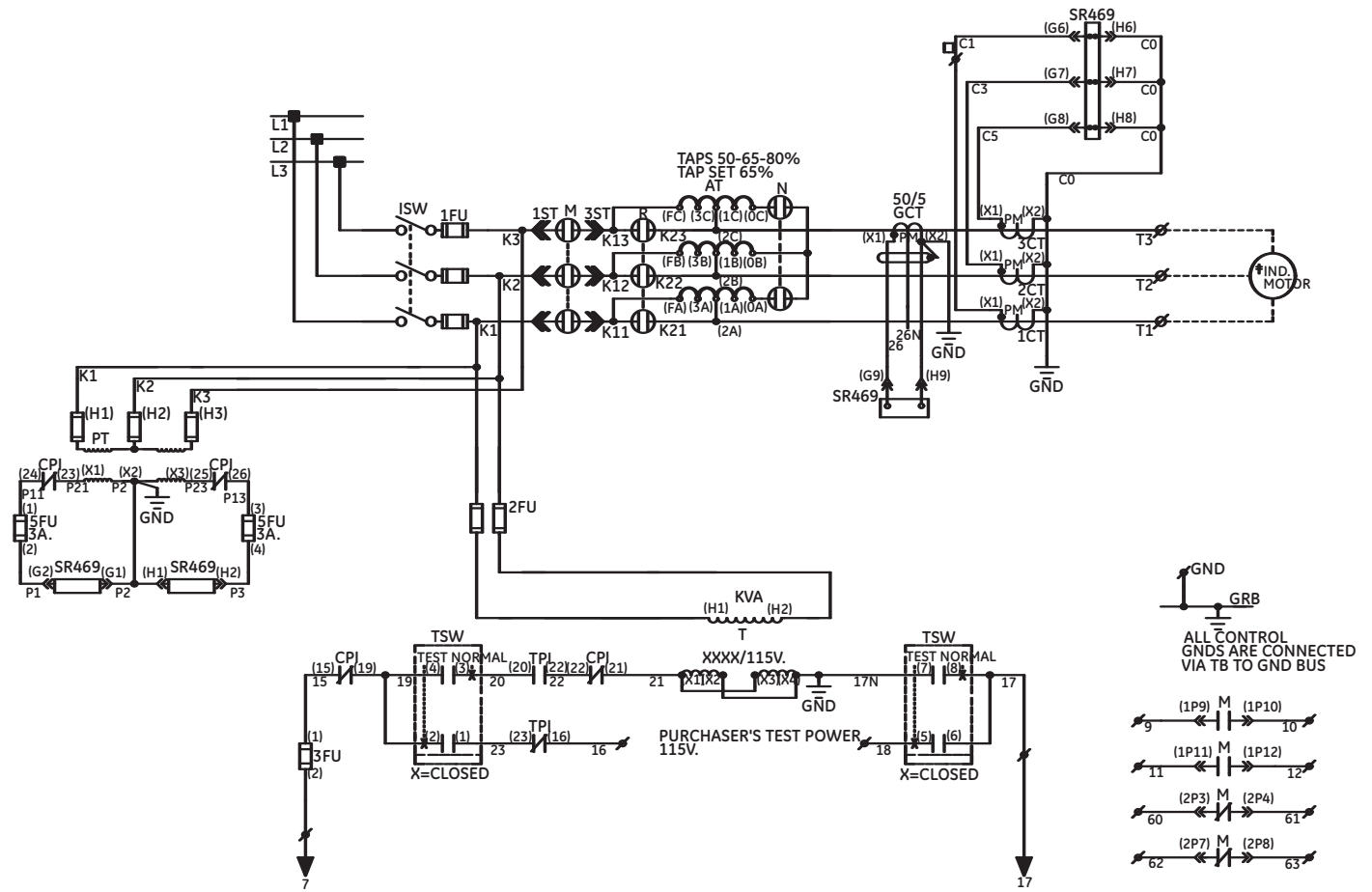

(continued on next page)

GE Limitamp® Medium Voltage Motor Control Typical Elementary Diagrams

800A Drawout RVAT with M469 Relay (Stationary also available)

(continued from previous page)

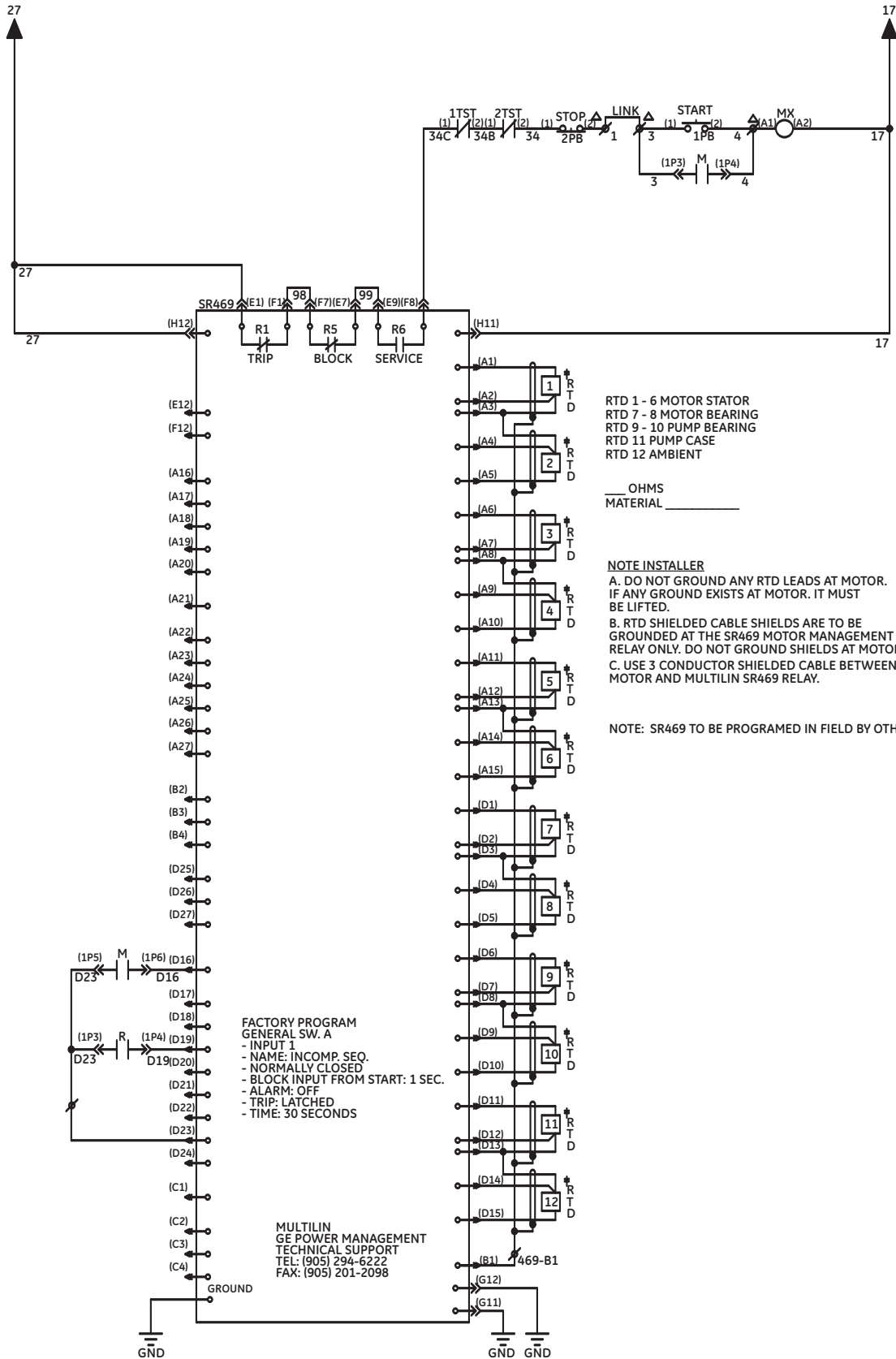

GE Limitamp® Medium Voltage Motor Control Guideform Specifications

Controllers-CR194 Vacuum Stationary & Drawout Contactors, 2400 -7200 Volts

General

These specifications cover NEMA Class E2 high-voltage control for ____ volts, ____ phase, ____ Hertz as follows:

Controller #1:

| | | | |
|-------------------|-----------------|----------------|---------------------------|
| (Full voltage) | (Non reversing) | controller for | (Squirrel-cage induction) |
| (Reduced voltage) | (Reversing) | | (Wound-rotor induction) |
| | | | (Brush-type synchronous) |
| | | | (Brushless synchronous) |

motor rated at ____ horsepower.

Controller #2, etc. (as shown above)

All Controllers

Controller(s) shall be fused type employing current-limiting sand power fuses that give the controller an interrupting rating of:

200 MVA, 3 phase symmetrical at 2400 Volts, 50/60 Hz
350 MVA, 3 phase symmetrical at 4200 Volts, 50/60 Hz
400 MVA, 3 phase symmetrical at 4800 Volts, 50/60 Hz
600 MVA, 3 phase symmetrical at 7200 Volts, 50/60 Hz

Contactors

Starter(s) shall employ magnetically held vacuum contactor(s) rated at:

for welded enclosure:

400 amperes at 7200 volts maximum, interrupting rating of 75 MVA, 3 phase symm.

800 amperes at 5000 volts maximum, interrupting rating of 75 MVA, 3 phase symm.

for bolted enclosure:

400 amperes at 5000 volts maximum, interrupting rating of 50 MVA, 3 phase symm.

Contactors shall be stationary (drawout for 400 amp contactor only) and the coil shall be removable without removing the contactor from the enclosure. The vacuum interrupter wear checks shall not require removal of the contactor.

Controller(s) shall be in a:

for welded enclosure:

One-high line-up of NEMA ____ enclosure(s) equipped with 3-ph (1200)(2000)(3000) amp horizontal AC bus

One-high individual NEMA ____ enclosure(s) equipped with provisions for terminating incoming cable

for bolted enclosure:

Two-high line-up of NEMA ____ enclosure(s) equipped with (1000)(2000)(3000) amp horizontal AC power bus

One-high line-up of NEMA ____ enclosure(s) equipped with (1000)(2000)(3000) amp horizontal AC power bus

The power bus shall be braced for 80 kA RMS asymmetrical or 50 kA RMS symmetrical.

For safety to personnel, enclosure(s) shall be compartmented into low-voltage control compartment with separate door, high-voltage compartment with separate interlocked door, AC bus compartment with protective barriers and cable entrance compartment.

The controller shall be isolated by a quick-make quick-break switch operated by an externally mounted operating handle. The isolating device shall disconnect the secondary of the control power transformer before opening the main circuit contacts.

Mechanical interlocks shall be provided to prevent:

1. Closing the isolation switch with the high-voltage door open.
2. Operation of the isolation switch while under load.
3. Opening of the high-voltage door when isolation switch is on.
4. Operation of the contactor when the isolation switch is in an intermediate position.

Note: For overload protection, one three-pole ambient-compensated thermal-overload relay, manually reset, shall be included.

Controllers rated 400 and 800 amperes shall be rated 60 kV Basic Impulse Level (BIL).

Options

Each controller shall contain protection against single-phasing due to a blown fuse and shall have blown fuse indication. (Solid-state relay protection)
(Latched contactors)

Control for Wound-rotor Induction Motors

Secondary control shall be fully magnetic. It shall provide automatic acceleration through ____ starting steps with uniform torque peaks using a NEMA Class ____ resistor.

The control shall provide for continuous speed regulation with ____ points of speed reduction with a maximum reduction of ____ % from full-load speed at ____ % full load torque.

Control for Synchronous Motors

DC field control for synchronous motors shall consist of one GE Multilin SPM starting and protection module equipped with digital displays for power factor, field current and line current, one field starting and discharge resistor and one electronic field contactor. Operation must be fully automatic.

GE Limitamp® Medium Voltage Motor Control

Guideform Specifications

Static field supplies shall be:

- (tapped transformer static field contactor [SFC])
- (adjustable silicon controlled rectified variable field contactor [SCR type VFC])
- (adjustable VFC with power factor regulation)
- (adjustable VFC with field current regulation)

Additional Functions

Control power at 120 volts shall be provided from a control power transformer in each controller. The transformer shall be protected by current-limiting fuses. Controller(s) shall provide instantaneous undervoltage protection when momentary contact push button is used, undervoltage release when maintained contact push button is used.

- (Push button) is to be (mounted on door)
- (Switch) (remotely located)

Finish

Finish shall be:

(ANSI-61 light gray over rust-resistant phosphate undercoat for indoor use.)

(ANSI-61 light gray over one or more rust-resistant phosphate undercoats for outdoor use.)

Controllers - CR7160 Vacuum Or Air-Break Draw Out, 2400-7200 Volts

FOR REPLACEMENT APPLICATIONS ONLY

General

These specifications cover NEMA Class E2 high-voltage control for ___ volts, ___ phase, ___ Hertz motors as follows:

Controller #1:

| | | | |
|-------------------|-----------------|----------------|---------------------------|
| (Full voltage) | (Non reversing) | controller for | (Squirrel-cage induction) |
| (Reduced voltage) | (Reversing) | | (Wound-rotor induction) |
| | | | (Brush-type synchronous) |
| | | | (Brushless synchronous) |

motor rated at ___ horsepower.

Controller #2, etc. (as shown above)

All Controllers

Controller(s) shall be fused type employing current-limiting power fuses that give the controller an interrupting rating of:

- 200 MVA, 3-phase symmetrical at 2400 volts, 50/60 Hz
- 350 MVA, 3-phase symmetrical at 4200 volts, 50/60 Hz
- 400 MVA, 3-phase symmetrical at 4800 volts, 50/60 Hz
- 600 MVA, 3-phase symmetrical at 7200 volts, 50/60 Hz

Starter(s) shall employ (vacuum) (magnetic air-break) line contactor(s) rated 400 amperes, 5000 volts and have an interrupting capacity of 50 MVA, 3-phase, symmetrical.

Starter(s) shall employ magnetic air-break line contactor(s) rated 700 amperes, 5000 volts and have an interrupting capacity of 80 MVA, 3-phase symmetrical.

Controller(s) shall be in a:

- one-high line-up of NEMA ___ enclosures with 3-phase (1000 amp) (2000 amp) AC power bus.
- free-standing one-high individual NEMA ___ enclosure(s) with provision for terminating incoming cable.
- two-high construction with NEMA ___ enclosure*, and with 3-phase (1000 amp) (2000 amp) AC power bus.
- three-high construction with NEMA ___ enclosure*, and with 3-phase (1000 amp) (2000 amp) AC power bus.

For safety to personnel, enclosure(s) shall be compartmented into low-voltage control compartment with separate door, high-voltage compartment with separate interlocked door, AC bus compartment with protective barriers and cable entrance compartment.

Line contactors shall be draw out type.

The controller shall be isolated by externally operated drawout stabs with shutter mechanism. The isolating device shall also open the secondary of the control power transformer. Interlocks shall be provided to prevent (1) inadvertent operation of the isolation mechanism underload, (2) opening the high-voltage compartment door without isolating the starter, and (3) closing the isolation switch with door open.

Note: For overload protection, one three-pole ambient-compensated thermal overload relay, hand-reset, shall be included.

Options

- (Solid-state relay protection)
- (Anti-single-phase trip bar)
- (Mechanical latching)

Control for Wound-rotor Induction Motors

Secondary control shall be fully magnetic. It shall provide automatic acceleration through ___ starting steps with uniform torque peaks using a NEMA Class ___ resistor.

The control shall provide for continuous speed regulation with ___ point of speed reduction with a maximum reduction of ___ percent from full-load speed at ___ % full-load torque.

Control for Synchronous Motors

DC field control for synchronous motors shall consist of one GE-Multilin SPM starting and protection module equipped with digital displays for power factor, field current and line current, one field starting and discharge resistor and one magnetic field contactor. Operation must be fully automatic.

GE Limitamp® Medium Voltage Motor Control

Guideform Specifications

Static field supplies shall be:

(tapped transformer SFC - Static Field Contactor)
(adjustable SCR type VFC - Variable Field Contactor)
(adjustable SCR type VFC with power-factor regulation)
(adjustable SCR type VFC with field current regulation)

Additional functions

Control power at 120 volts shall be provided from a control-power transformer in each controller. Transformer shall be protected by current-limiting fuses.

Controller(s) shall provide instantaneous undervoltage protection when momentary-contact push button is used, undervoltage release when maintained-contact switch is used.

(Push button) is to be (mounted on door).
(Switch) (remotely located).

Finish

Finish shall be:

(ANSI-61 light gray over rust-resistant phosphate undercoat for indoor use.)

(ANSI-61 light gray over one or more rust-resistant phosphate undercoats for outdoor use.)

Starters - CR194 Vacuum

All Starters

| | |
|---------------|---|
| Enclosure | NEMA Type 1 general purpose, ventilated |
| Connections | |
| Incoming Line | Entrance top or bottom. Cables separated by barrier from both low- and high-voltage compartments. |
| Motor Cable | Entrance top or bottom. Cables separated by barrier from both low- and high-voltage compartments. |

Squirrel-Cage-Motor Starters

Full-Voltage Non-Reversing (FVNR)

High-voltage compartment

- 1- Set of bolt-in current-limiting fuses and supports
- 1- Externally operated disconnect switch
- 1- Three-pole vacuum contactor

1- Set of mechanical interlocks to prevent opening the disconnect when the contactor is on, to prevent opening the door when the disconnect is on, to prevent closing the contactor when the disconnect is in an intermediate position, and to prevent closing of the disconnect when the high-voltage door is open

- 1- Fused primary control power transformer (CPT)
- 3- Current transformers
- 3- Terminals for motor cable connections

Low-voltage compartment

- 1- Three-pole, ambient-compensated thermal overload

relay, hand-reset

- 1- NORMAL-TEST selector switch
- 1- Control-circuit fuse

On door

- 1- START-STOP push button, oil-tight, flush-mounted

Full-Voltage Reversing (FVR)

Same as for full-voltage non-reversing with addition of following:

Auxiliary enclosure

- 2- Three-pole vacuum contactors for reversing

On door

- 1- FORWARD-REVERSE-STOP push button, oil-tight, flush-mounted (replacing START-STOP push button)

Reduced-Voltage Non-Reversing (RVNR) (Primary Reactor)

Same as for full-voltage non-reversing with addition of following:

- 1- Three-pole vacuum contactor used as a RUN contactor

Auxiliary enclosure (1-high)

- 1- Reduced-voltage starting reactor with taps for 50-, 65- and 80-percent line voltage

Low voltage compartment

- 1- Definite time transfer relay

Reduced-Voltage Non-Reversing (RVNR) (Autotransformer closed transition)

Same as for full-voltage non-reversing with addition of following:

- 1- Three-pole vacuum contactor used as a RUN contactor

Auxiliary enclosure (1-high)

- 2- Three-pole vacuum contactor - neutral, and 80-percent line voltage

Low-voltage compartment

- 1- Definite time transfer relay

Wound-Rotor-Motor Starters

Non-Reversing

Same as for squirrel-cage FVNR with addition of following:

Secondary enclosure

- 1- Set of intermediate accelerating contactors
- 1- Final accelerating contactor
- 1- Set of definite time accelerating relays

Resistor enclosure

- 1- Set of starting-duty resistors, NEMA Class 135

Reversing

Same as for non-reversing with addition of following:

High-voltage compartment

- 1- Three-pole vacuum contactor used for reversing

On door

- 1- FORWARD-REVERSE-STOP push button, oil-tight, flush-mounted (replacing START-STOP push button)

GE Limitamp® Medium Voltage Motor Control Guideform Specifications

Brush-Type Synchronous-Motor Starters

Full-Voltage Non-Reversing (FVNR)

Same as for squirrel-cage FVNR with addition of following:

Low voltage compartment

1- Field application and discharge contactor

On door

1- GE-Multilin SPM solid-state synchronizing device for precision-angle field application, load-angle field removal and squirrel-cage protection with built-in digital power factor and line ammeter

1- Line amps display - digital readout (part of GE-Multilin SPM)

1- Field amps display - digital readout (part of GE-Multilin SPM)

On top

1- Field starting and discharge resistor

Reduced-Voltage Non-Reversing (RVNR)

Same as for full-voltage non-reversing with addition of preceding reduced voltage sections contactor

Brushless, Synchronous-Motor Starters

Full-Voltage Non-Reversing (FVNR)

Same as for squirrel-cage FVNR with addition of following:

Low voltage

1- Brushless-exciter field supply (7 amps maximum)

Compartment

1- Variable autotransformer for exciter field supply

On door

1- GE Multilin SPM solid-state synchronizing device for precision time-delay field application, load-angle field removal and squirrel-cage protection with built-in digital power factor and line ammeter

1- Line amps display - digital readout (part of GE Multilin SPM)

1- Field amps display - digital readout (part of GE Multilin SPM)

Reduced-Voltage Non-Reversing (RVNR)

Same as for full-voltage non-reversing with addition of preceding reduced voltage sections

Note: Drawout contactor available only for FVNR applications.

Information contained in this application guide is based on established industry standards and practices. It is published in the interest of assisting in the preparation of plans and specifications for medium voltage motor control. Neither the General Electric Company nor any person acting on its behalf assumes any liability with respect to the use of, or for damages or injury resulting from the use of any information contained in this application guide.

GE Consumer & Industrial

41 Woodford Avenue
Plainville, CT 06062

© 2018 General Electric Company

www.geelectrical.com



imagination at work