

456 Series Fuse

Very Fast Acting Fuse



Description

The High Current NANO²® Fuse is a small square surface mount fuse that is designed to support higher current requirements of various applications.

Features

- Surface mount high current fuse
- Fully compatible with lead-free solder alloys and higher temperature profiles associated with lead-free assembly
- RoHS compliant and Halogen Free
- Available in ratings of 20 to 40 Amperes
- UL Recognized UL/CSA/NMX 248-1 and UL/CSA/NMX 248-14
- Conforms to IEC/EN 60127-1 and IEC/EN 60127-7
- Conforms to DENAN's Appendix 3

Additional Information



Resources



Accessories



Samples

Applications

- Voltage regulator module for PC server
- Cooling fan system for PC server
- Storage system power
- Basestation power supply

Electrical Characteristics

| % of Ampere Rating | Opening Time |
|--------------------|---------------------|
| 100% | 4 hours, Minimum |
| 200% | 60 seconds, Maximum |

Agency Approvals

| Agency | Agency File/Certificate Number | Ampere Rating |
|--------|--------------------------------|---------------|
| cULus | E10480 | 20A - 40A |
| △ | J50446929 | 20A - 40A |
| PS E | NBK030308-JP1021 | 20A - 30A |
| SP | 29862 | 20A - 40A |

Electrical Specifications

| Ampere Rating (A) | Amp Code | Max Voltage Rating (V) | Interrupting Rating ⁴ | Nominal Cold Resistance (Ohms) | Nominal Melting I ² t (A ² Sec.) | Nom Voltage Drop (mV) | Agency Approvals | | | |
|-------------------|----------|------------------------|--|--------------------------------|--|-----------------------|------------------|---|------|----|
| | | | | | | | cULus | △ | PS E | SP |
| 20 | 020. | 125 | 100A @125VAC 300A @ 65VAC 300A @ 100VDC 1000A @ 32VDC 500A @ 72VDC | 0.00230 | 18 | 64.7 | x | x | x | x |
| 25 | 025. | 125 | 100A @ 125VAC 300A @ 65VAC 500A @ 72VDC 1000A @ 32VDC | 0.00192 | 45 | 68.38 | x | x | x | x |
| 30 | 030. | 125 | 100A @ 125VAC 300A @ 65VAC 1000A @ 32VDC 500A @ 72VDC | 0.00132 | 81 | 69.9 | x | x | x | x |
| 40 | 040. | 72 | 180A @ 72VDC 600A @ 60VDC | 0.00105 | 191 | 55 | x | x | - | x |

Notes:

1. Cold resistance measured at less than 10% of rated current at 23°C.
2. Agency Approval Table Key: X=Approved or Certified, P=Pending.
3. I²t values stated for 1 msec opening time.
4. Interrupting Rating may differ based on Agency Approval. See Agency Approval certificate for more details.

456 Series Fuse

Very Fast Acting Fuse

Temperature Re-rating Curve

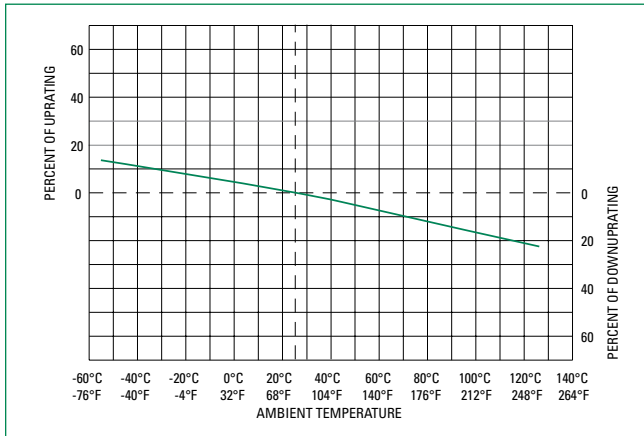

Note:
1. Rerating depicted in this curve is in addition to the standard derating of 25% for continuous operation.

Average Time Current Curves

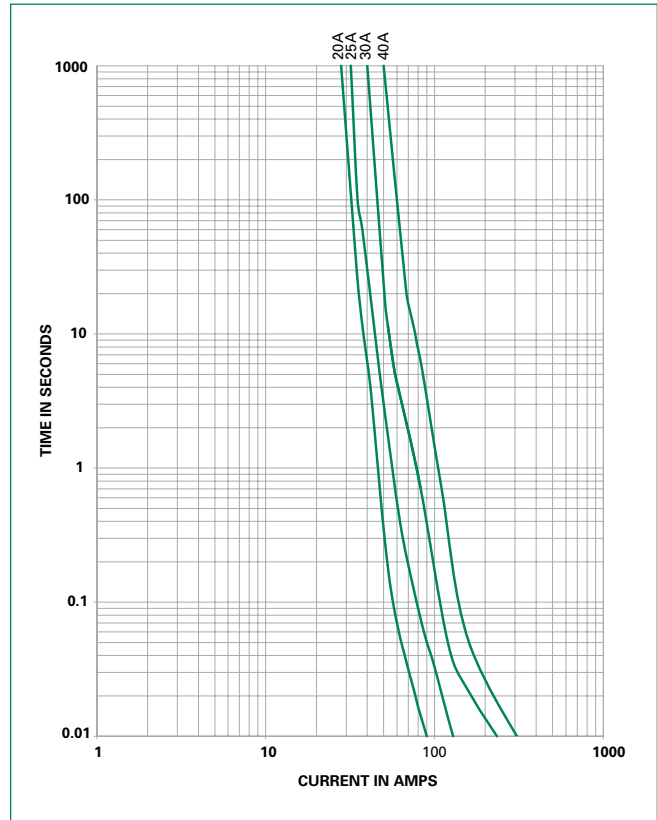

Soldering Parameters – Reflow Soldering

| | | |
|--|------------------------------------|-------------------------|
| Reflow Condition | | Pb – Free assembly |
| Pre Heat | - Temperature Min ($T_{s(min)}$) | 150°C |
| | - Temperature Max ($T_{s(max)}$) | 200°C |
| | - Time (Min to Max) (t_s) | 60 – 180 secs |
| Average ramp up rate (Liquidus Temp (T_L) to peak) | | 5°C/second max. |
| $T_{s(max)}$ to T_L - Ramp-up Rate | | 5°C/second max. |
| Reflow | - Temperature (T_L) (Liquidus) | 217°C |
| | - Temperature (t_L) | 60 – 150 seconds |
| Peak Temperature (T_p) | | 260 ^{+0/-5} °C |
| Time within 5°C of actual peak Temperature (t_p) | | 20 – 40 seconds |
| Ramp-down Rate | | 5°C/second max. |
| Time 25°C to peak Temperature (T_p) | | 8 minutes max. |
| Do not exceed | | 260°C |

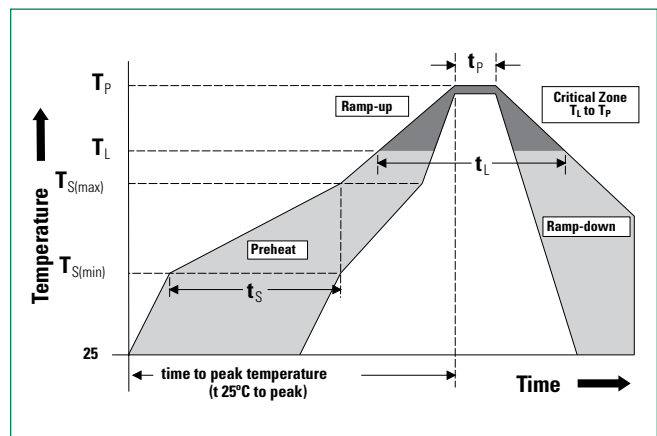

456 Series Fuse

Very Fast Acting Fuse

Product Characteristics

| | |
|--|---|
| Materials | Body: Ceramic Cap: Silver Plated Brass |
| Product Marking | Body: Brand Logo, Current Rating |
| Insulation Resistance | MIL-STD-202, method 302, Test Condition A (10,000 ohms, Minimum) |
| Solderability | MIL-STD-202, Method 208 |
| Resistance to Soldering Heat | MIL-STD-202, Method 210, Test Condition B (10 sec at 260°C) Min. copper layer thickness = 100µm Min. copper trace width = 20A, 30 10mm (20A, 30A) / 15mm (40A) |
| PCB Recommendation for Thermal Management | Alternate methods of thermal management may be used. In such cases, under normal operations, the maximum temperature of the fuse body should not exceed 90°C in a 25°C environment. |

| | |
|-----------------------------------|---|
| Operating Temperature | -55°C to 125°C with proper derating |
| Thermal Shock | MIL-STD-202, Method 107, Test Condition B (5 cycles -65°C to 125°C) |
| Vibration | MIL-STD-202, Method 201 (10-55 Hz) |
| Moisture Sensitivity Level | J-STD-020, Level 1 |
| Moisture Resistance | MIL-STD-202 Method 106, High Humidity (90-98%RH), Heat (65°C) |
| Salt Spray | MIL-STD-202, Method 101, Test Condition B |
| Mechanical Shock | MIL-STD-202, Method 213, Test Condition I (100 G's peak for 6 milliseconds) |

Dimensions

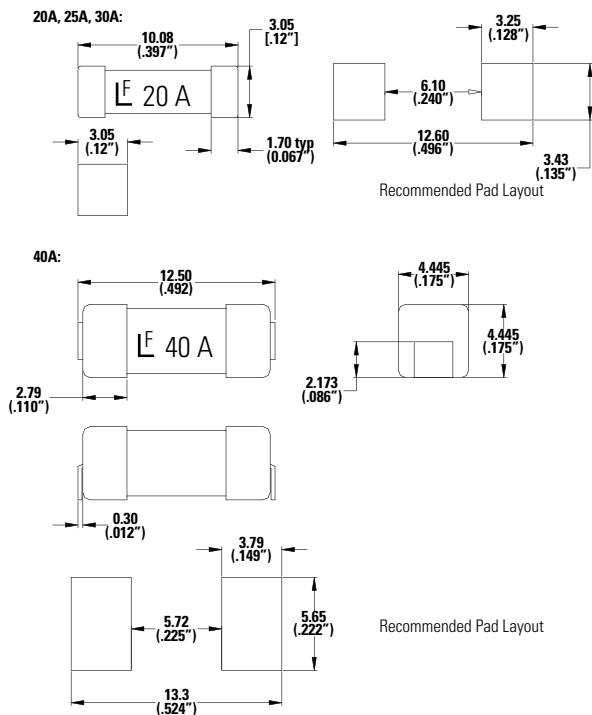

Part Numbering System

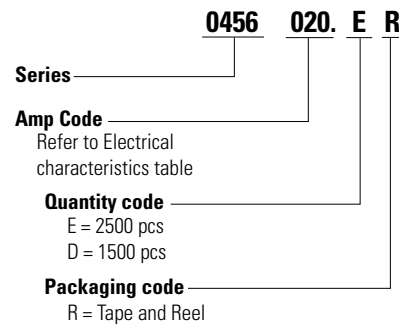

Packaging

| Rating | Packaging Option | Packaging Specification | Quantity | Quantity & Packaging Code |
|---------------|---------------------|--------------------------------|----------|---------------------------|
| 20A, 25A, 30A | 24 mm Tape and Reel | EIA RS-481-2 | 2500 | ER |
| 40A | 24 mm Tape and Reel | EIA RS-481-2 (IEC 286, part 3) | 1500 | DR |

Disclaimer Notice - Littelfuse products are not designed for, and shall not be used for, any purpose (including, without limitation, automotive, military, aerospace, medical, life-saving, life-sustaining or nuclear facility applications, devices intended for surgical implant into the body, or any other application in which the failure or lack of desired operation of the product may result in personal injury, death, or property damage) other than those expressly set forth in applicable Littelfuse product documentation. Warranties granted by Littelfuse shall be deemed void for products used for any purpose not expressly set forth in applicable Littelfuse documentation. Littelfuse shall not be liable for any claims or damages arising out of products used in applications not expressly intended by Littelfuse as set forth in applicable Littelfuse documentation. The sale and use of Littelfuse products is subject to Littelfuse Terms and Conditions of Sale, unless otherwise agreed by Littelfuse. Information furnished is believed to be accurate and reliable. However, users should independently evaluate the suitability of and test each product selected for their own applications. Littelfuse products are not designed for, and may not be used in, all applications. Read complete Disclaimer Notice at www.littelfuse.com/disclaimer-electronics.