

**PRECISION METERING VALVE**  
**1/8" and 1/4" NPT**  
**1/8" and 1/4" Dual Ferrule Tube**  
**Vacuum - 1000 Psig (68.9 Bar)**

PMV  
 P

SERIES

**Description**

Series PMV Precision Metering Valves are designed for accurate and repeatable flow control of fluids and gases. Valves feature a one-piece forged body and a screwed bonnet design. Stainless steel 3 degree tapered stem seals bubble tight into an Acetal soft seat. With panel mounting and lockable adjustment standard, these valves offer cost effective solutions for precise metering.

**Features**

- Straight or Angle Flow Patterns
- Forged Body Brass or Stainless Steel Construction
- NPT or Dual Ferrule Tube Connections
- Unique Soft Seat Provides Positive Shut Off
- Wear Compensating Knob Adjustment
- Locking Screw Prevents Inadvertent Flow Changes
- Stem Threads are isolated from System Fluid
- 100% Factory Tested for Leakage

**Technical Data**

Maximum Operating Pressure @ 100° F  
 Brass and Stainless: 1000 Psig (68.9 Bar)  
 Stem Taper: 3 Degree (included angle)  
 Stem Pitch: 40 Threads per inch  
 Orifice: 0.055" (1.4 mm)  
 Flow Coefficient (Cv): 0.04  
 Panel Mounting  
 Panel Mount Hole: 9/16" (14.3 mm)  
 Max Panel Mount Thickness: 1/8" (3.3 mm)  
 Factory Preset for zero flow at positive stop with 150 Psig (10.34 Bar)  
 Temperature Range:  
 Seal Dependent (See How To Order)

**Materials of Construction**

Component	Valve Body Material	
	Brass	Stainless Steel
Body	Forged Brass, ASTM 377	Forged 316 SS, ASTM A182
Bonnet	Brass, ASTM B16, Nickel Plated	316 SS, ASTM A479
Stem	316 SS, ASTM A479	
Knob and Panel Nut	Brass, ASTM B16, Nickel Plated	
Seat Insert	Acetal CoPolymer, ASTM D4181	
O-Ring	Buna-N, Neoprene, Ethylene Propylene or Viton®	
Set Screw (2)	18-8 SS, ASTM A182	

Nickel Plating per ASTM B689  
 Stem Threads and O-Rings are lubricated with Krytox®



# PRECISION METERING VALVE

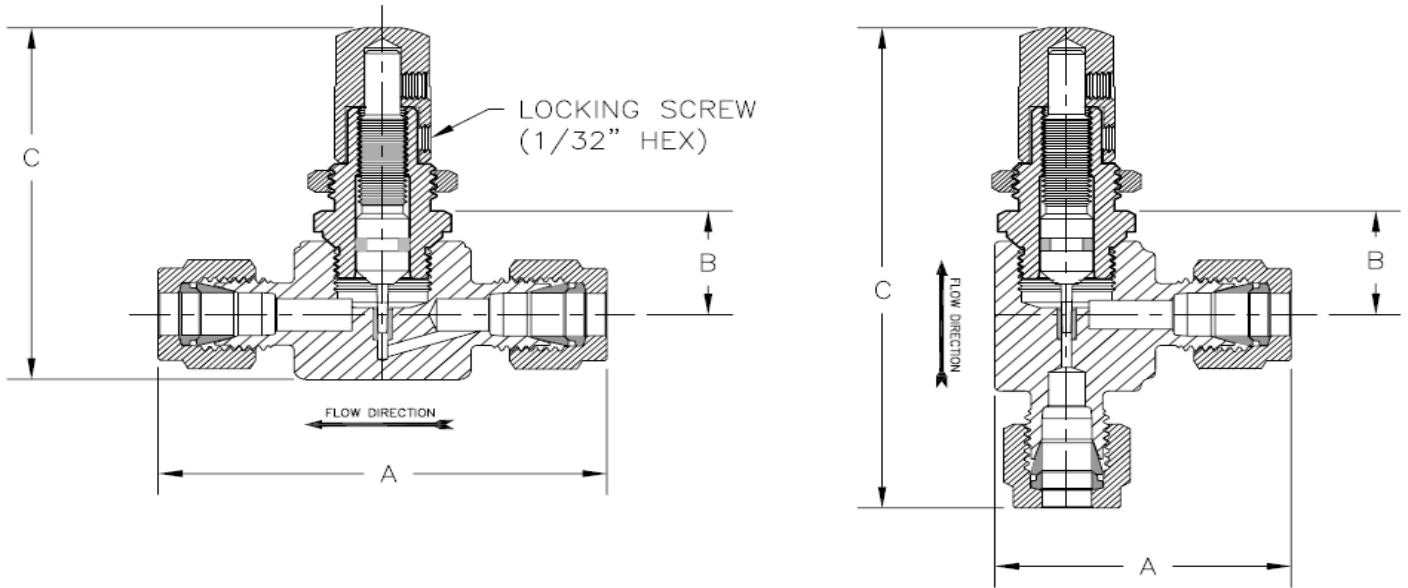

## Dimensional Data

Model Code	Port Configuration			Dimensions in inches (mm)				
	Inlet	Outlet	Configuration	Orifice	OAL "A"	Panel To C/L "B"	Height "C"	Knob Diameter
PMV-2T	1/8" Tube		Straight	0.055 (1.4)	2.07 (52.58)	.62 (15.75)	2.10 (53.34)	0.50 (12.7)
PMV-4T	1/4" Tube				2.31 (58.70)		2.10 (53.34)	
PMV-2TA	1/8" Tube		Angle		1.43 (36.20)		2.75 (69.72)	
PMV-4TA	1/4" Tube				1.53 (38.74)		2.89 (73.30)	
PMV-2F	1/8" Female NPT		Straight		1.63 (41.28)		2.10 (53.34)	
PMV-2FA			Angle		1.19 (30.15)		2.50 (63.50)	
PMV-2PTA	1/8" Male NPT	1/8" Tube	Angle		1.43 (36.20)		2.53 (64.14)	
PMV-2P	1/8" Male NPT		Straight		1.63 (41.28)		2.10 (53.34)	
PMV-2PA			Angle		1.19 (30.15)		2.53 (64.14)	
PMV-4P	1/4" Male NPT		Straight		1.96 (49.78)		2.10 (53.34)	
PMV-4PA			Angle		1.35 (34.37)		2.71 (68.83)	

**Note:** Dimensions shown with Bi-Lok nuts finger-tight. Dimensions are in inches (millimeters), for reference only and subject to change. All valve bodies are 3/4" (19 mm) wide. NPT Threads per ASME B1.20.1

## Flow Coefficient (Cv) @ Turns Open

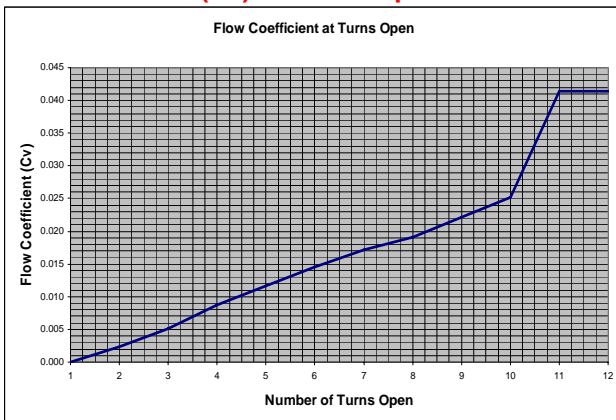

**Note:** Valves may require up to one full turn before flow is evident.

## How To Order

PMV - 4T SS - V - X

Model Code: PMV - Precision Metering Valve  
See Dimensional Data Above

Material Code: B - Brass  
SS - 316 Stainless Steel

Seal Material:  
B - Buna-N, -40° F to 180° F (-40° C to 82° C)  
V - Viton, -10° F to 180° F (-23° C to 82° C)  
N - Neoprene, -40° F to 180° F (-40° C to 82° C)  
EP - Ethylene Propylene, -50° F to 180° F (-46° C to 82° C)

Cleaning Option:  
X - Cleaned and Packaged for Oxygen Service

Viton® and Krytox® are registered trade marks of DuPont.

PROPER COMPONENT SELECTION – When specifying a component, the total system design must be considered to ensure safe and trouble-free performance. Intended component function, materials compatibility, pressure ratings, installation, environment and maintenance are the responsibility of the system designer.



**1865 Route 23 South PO Box 768 Butler, New Jersey 07405 973.838.6500 Fax 973.838.4888**