

# B838 Series Regulator

## Twin Parallel Flow Service Regulators

The B838 series regulators are designed for commercial and industrial applications. The twin unit concept provides excellent control of widely varying inlet pressures and fluctuating flow rates. With the twin internal relief valves and internal monitor available, these regulators have unmatched over pressure protection, while providing significant cost savings from expensive piping and relief valve sets.

### Description

**B838N** – A spring loaded self operated regulator with no internal relief. This regulator can be used on low or intermediate inlet pressures where an internal relief valve is not required.

**B838R** – The largest internal relief service regulator. This model features twin 2-1/2" internal relief vents that allow the B838R to be used on any inlet system up to the regulator's maximum operating pressure rating.

**B838IMN** – Equipped with an internal monitor (IM) orifice that operates upon failure of the main valve. This orifice features the safety advantage of a second gas-tight lock-up seat if the primary valve seat fails to produce the adjusted outlet pressure. The monitor also controls gas flow between the failed open flow and no flow, thereby providing complete secondary regulation. The "N" designation signifies no internal relief valve.

**B838IMR** – Equipped with an internal monitor (IM) orifice as a primary form of overpressure protection that operates

upon failure of the main valve seat. The B8381MR is also equipped with secondary twin internal relief valves that open in the event that both the main seat and the internal monitor cannot function.

**B838IMRV** – Equipped with an internal monitor (IM) orifice as a primary form of overpressure protection that operates upon failure of the main valve. It is also equipped with the vent-hole option, which gives a warning indication that the regulator is on monitor control in the event of main valve failure. The vent-hole option consists of a 1/16" hole in the sliding orifice that allows a small amount of gas to bleed downstream, which causes the relief valves to weep gas. In the unlikely event the main valve and the monitor valve fails to function, the B838IMRV is equipped with secondary or back-up twin internal relief valves.

### Option Designations

N	No internal relief
R	Internal Relief
IMN	Internal monitor without internal relief
IMR	Internal monitor with internal relief
IMRV	Internal monitor with internal vent

### Benefits

- » Eliminates parallel regulator piping installations
- » Light weight
- » Fast response protects equipment from shock damage
- » Field inspection of the internal monitor and internal relief valves without customer shut-off or by-pass
- » Unmatched overpressure protection with internal monitor plus internal relief options

### Features

- » Interchangeable brass orifice
- » Combined 226 in 2 of diaphragm area
- » Twin Spring-loaded internal relief valve assemblies
- » Field interchangeable adjustment springs
- » No special adjustment tools required
- » Controlled size breather orifice eliminates pulsation and provides normal actuation at low flows
- » Wide range of valve body sizes

## B838 SERIES TWIN PARALLEL FLOW SERVICE REGULATORS

### Shipping weight

One regulator per box

Size	Box weight
2" x 2" NPT	57 lbs.
2" x 2" Flanged	59 lbs.
2" x 3" Flanged	70 lbs.
2" x 4" Flanged	80 lbs.

### B838 Dimensions

Valve body	A	B	C	D	E	F	G	H
2-inch or 3-inch	25	13	37-3/4	12-3/4	18-7/8	12-7/8	6-1/2	16-1/4

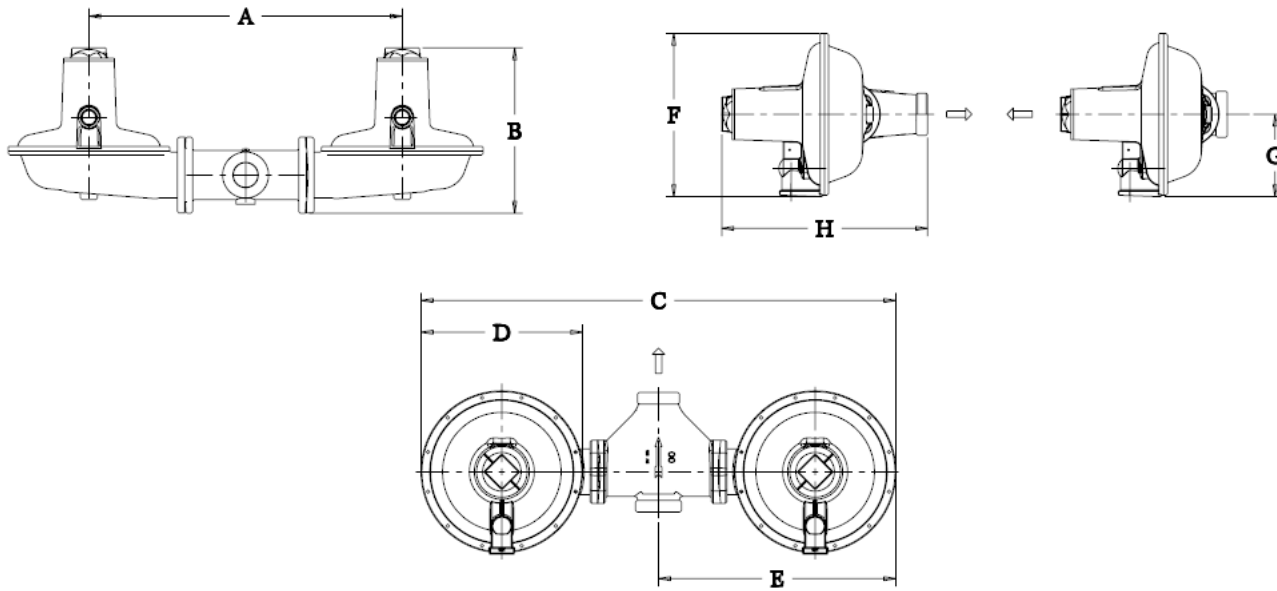

## OPERATIONAL SCHEMATIC

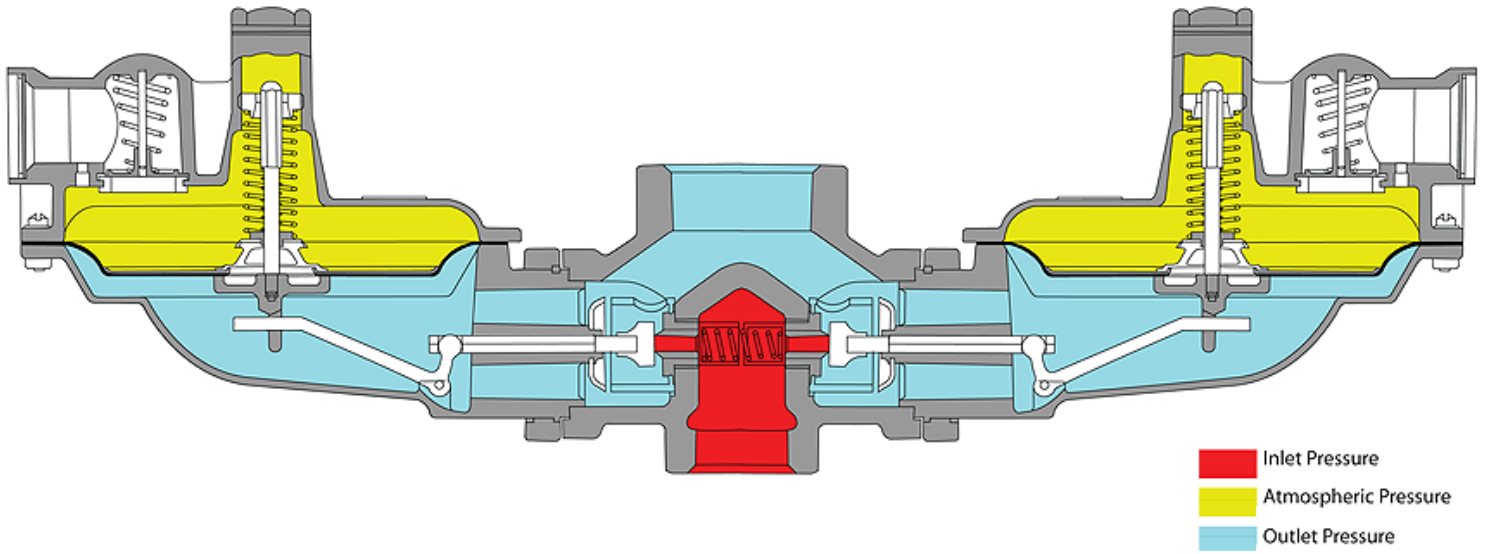

**SPRING DATA, SPRING COLOR OUTLET PRESSURE RANGE**

		<b>B838N Adjusted Outlet Pressure Range*</b>		<b>B838R Adjusted Outlet Pressure Range*</b>		
<b>Orifice size</b>	<b>Inlet pressure</b>	<b>Spring color</b>	<i>Spring adjustment ferrule at min. and max. depths</i>			
			<b>Outlet pressure</b>			
			<b>Minimum</b>	<b>Maximum</b>	<b>Minimum</b>	<b>Maximum</b>
3/8"	25 PSIG	Orange	2.6" w.c.	5.0" w.c.	2.6" w.c.	4.3" w.c.
		Brown	3.7" w.c.	7.8" w.c.	4.5" w.c.	7.4" w.c.
		Green	4.1" w.c.	10.2" w.c.	4.8" w.c.	8.5" w.c.
		Black	6.3" w.c.	16.7" w.c.	7.9" w.c.	14.5" w.c.
		Purple	10.4" w.c.	23" w.c.	12.1" w.c.	22" w.c.
		Blue	0.5 PSIG	1.4 PSIG	.6 PSIG	1.1 PSIG
		Silver	1.4 PSIG	3.2 PSIG	1.0 PSIG	2.1 PSIG
		Yellow	2.9 PSIG	4.9 PSIG	2.8 PSIG	4.9 PSIG
		Red	2.9 PSIG	6.3 PSIG*	3.3 PSIG	6.2 PSIG*
1/2"	25 PSIG	Orange	2.7" w.c.	5.0" w.c.	2.7" w.c.	4.3" w.c.
		Brown	3.9" w.c.	8.2" w.c.	4.8" w.c.	7.8" w.c.
		Green	4.5" w.c.	10.7" w.c.	5.3" w.c.	8.9" w.c.
		Black	6.8" w.c.	18.0" w.c.	8.5" w.c.	15.6" w.c.
		Purple	10.7" w.c.	24" w.c.	12.3" w.c.	23" w.c.
		Blue	0.6 PSIG	1.5 PSIG	.7 PSIG	1.2 PSIG
		Silver	1.4 PSIG	3.3 PSIG	1.0 PSIG	2.1 PSIG
		Yellow	2.3 PSIG	4.5 PSIG	2.2 PSIG	4.5 PSIG
		Red	2.9 PSIG	6.4 PSIG*	3.3 PSIG	6.2 PSIG*
5/8"	25 PSIG	Orange	2.8" w.c.	5.8" w.c.	3.0" w.c.	4.6" w.c.
		Brown	4.3" w.c.	9.2" w.c.	5.1" w.c.	8.1" w.c.
		Green	5.2" w.c.	11.8" w.c.	5.6" w.c.	9.3" w.c.
		Black	7.8" w.c.	19.8" w.c.	8.9" w.c.	16.0" w.c.
		Purple	10.9" w.c.	24.5" w.c.	12.4" w.c.	23" w.c.
		Blue	0.6 PSIG	1.7 PSIG	.7 PSIG	1.2 PSIG
		Silver	1.5 PSIG	3.6 PSIG	1.1 PSIG	2.2 PSIG
		Yellow	2.3 PSIG	4.5 PSIG	2.2 PSIG	4.6 PSIG
		Red	3.0 PSIG	7.2 PSIG*	3.3 PSIG	6.3 PSIG*
3/4"	25 PSIG	Orange	3.0" w.c.	6.2" w.c.	3.5" w.c.	4.9" w.c.
		Brown	4.7" w.c.	9.6" w.c.	5.5" w.c.	8.6" w.c.
		Green	5.7" w.c.	12.3" w.c.	6.0" w.c.	9.5" w.c.
		Black	8.7" w.c.	20.1" w.c.	9.2" w.c.	16.3" w.c.
		Purple	11.1" w.c.	24.7" w.c.	13.9" w.c.	24" w.c.
		Blue	.7" w.c.	1.7" w.c.	.7 PSIG	1.2 PSIG
		Silver	1.5 PSIG	3.6 PSIG	1.1 PSIG	2.2 PSIG
		Yellow	2.3 PSIG	4.5 PSIG	2.2 PSIG	4.6 PSIG
		Red	3.0 PSIG	7.5 PSIG*	3.4 PSIG	6.3 PSIG*

**B838N Adjusted Outlet Pressure Range\***

**B838R Adjusted Outlet Pressure Range\***

Orifice size	Inlet pressure	Spring color	Spring adjustment ferrule at min. and max. depths			
			Outlet pressure			
			Minimum	Maximum	Minimum	Maximum
1"	25 PSIG	Orange	4.3" w.c.	7.2" w.c.	4.2" w.c.	5.6" w.c.
		Brown	5.9" w.c.	10.8" w.c.	6.2" w.c.	9.3" w.c.
		Green	6.8" w.c.	13.3" w.c.	6.9" w.c.	10.2" w.c.
		Black	9.6" w.c.	21.5" w.c.	10.1" w.c.	17.3" w.c.
		Purple	13.5" w.c.	24.3" w.c.	14" w.c.	24.2" w.c.
		Blue	.7 PSIG	1.7 PSIG	.7 PSIG	1.2 PSIG
		Silver	1.5 PSIG	3.7 PSIG	1.1 PSIG	2.3 PSIG
		Yellow	2.3 PSIG	4.5 PSIG	2.3 PSIG	4.7 PSIG
		Red	3.0 PSIG	7.1 PSIG*	3.4 PSIG	6.4 PSIG*
1-1/4"	10 PSIG	Orange	3.2" w.c.	6.4" w.c.	3.5" w.c.	5.0" w.c.
		Brown	4.7" w.c.	9.6" w.c.	5.7" w.c.	8.6" w.c.
		Green	5.6" w.c.	12.2" w.c.	6.2" w.c.	9.7" w.c.
		Black	8.4" w.c.	20.0" w.c.	9.2" w.c.	16.5" w.c.
		Purple	13.7" w.c.	24.5" w.c.	14" w.c.	24.2" w.c.
		Blue	.6 PSIG	1.6 PSIG	.7 PSIG	1.2 PSIG
		Silver	1.4 PSIG	3.5 PSIG	1.1 PSIG	2.2 PSIG
		Yellow	2.3 PSIG	4.5 PSIG	2.2 PSIG	4.5 PSIG
		Red	2.9 PSIG	6.2 PSIG*	3.2 PSIG	6.3 PSIG*

\*Maximum allowable outlet pressure is 5.00 PSIG

**SPRING DATA, SPRING COLOR OUTLET PRESSURE RANGE, MODELS B838 IMN AND IMR**

		<b>B838IMN Adjusted Outlet Pressure Range</b>		<b>B838IMR Adjusted Outlet Pressure Range</b>		
<i>Spring adjustment ferrule at min. and max. depths</i>						
<b>Orifice size</b>	<b>Inlet pressure</b>	<b>Spring color</b>	<b>Outlet pressure</b>			
			<b>Minimum</b>	<b>Maximum</b>	<b>Minimum</b>	<b>Maximum</b>
3/8"	25 PSIG	Orange	2.6" w.c.	4.5" w.c.	2.7" w.c.	4.5" w.c.
		Brown	3.6" w.c.	7.2" w.c.	4.0" w.c.	6.9" w.c.
		Green/white	4.7" w.c.	8.9" w.c.	5.3" w.c.	8.1" w.c.
		Black	4.9" w.c.	14.3" w.c.	6.7" w.c.	12.9" w.c.
		Purple	10.1" w.c.	15.1" w.c.	11.5" w.c.	19.1" w.c.
		Blue	0.3 PSIG	1.0 PSIG	0.5 PSIG	1.0 PSIG
		Silver	0.8 PSIG	2.4 PSIG	1.1 PSIG	2.1 PSIG
		Yellow	1.5 PSIG	4.7 PSIG	2.3 PSIG	4.3 PSIG
		Red	1.6 PSIG	6.0 PSIG	2.2 PSIG	5.0 PSIG
1/2"	25 PSIG	Orange	2.6" w.c.	4.5" w.c.	2.8" w.c.	4.3" w.c.
		Brown	3.6" w.c.	7.2" w.c.	4.2" w.c.	7.0" w.c.
		Green/white	4.7" w.c.	8.9" w.c.	5.3" w.c.	8.2" w.c.
		Black	4.9" w.c.	14.3" w.c.	6.8" w.c.	13.1" w.c.
		Purple	10.7" w.c.	21" w.c.	11" w.c.	19.2" w.c.
		Blue	0.3 PSIG	1.0 PSIG	0.5 PSIG	1.0 PSIG
		Silver	0.8 PSIG	2.4 PSIG	1.2 PSIG	2.2 PSIG
		Yellow	1.5 PSIG	4.7 PSIG	2.4 PSIG	4.3 PSIG
		Red	1.6 PSIG	6.0 PSIG*	2.4 PSIG	5.0 PSIG*
5/8"	25 PSIG	Orange	2.7" w.c.	4.9" w.c.	2.9" w.c.	4.6" w.c.
		Brown	4.2" w.c.	7.4" w.c.	4.5" w.c.	7.0" w.c.
		Green/white	4.6" w.c.	9.2" w.c.	6.0" w.c.	8.7" w.c.
		Black	4.7" w.c.	14.5" w.c.	7.3" w.c.	13.4" w.c.
		Purple	11.3" w.c.	22" w.c.	12.7" w.c.	23" w.c.
		Blue	0.3 PSIG	1.1 PSIG	0.5 PSIG	1.0 PSIG
		Silver	0.8 PSIG	2.4 PSIG	1.2 PSIG	2.2 PSIG
		Yellow	0.5 PSIG	4.8 PSIG	2.4 PSIG	4.4 PSIG
		Red	1.6 PSIG	6.0 PSIG*	2.6 PSIG	5.1 PSIG*
3/4"	25 PSIG	Orange	3.2" w.c.	5.5" w.c.	3.6" w.c.	4.8" w.c.
		Brown	4.6" w.c.	8.0" w.c.	4.6" w.c.	7.4" w.c.
		Green/white	5.1" w.c.	10.0" w.c.	5.9" w.c.	9.2" w.c.
		Black	5.2" w.c.	15.1" w.c.	7.0" w.c.	13.6" w.c.
		Purple	12.1" w.c.	23" w.c.	12.9" w.c.	24" w.c.
		Blue	0.3 PSIG	1.1 PSIG	0.5 PSIG	1.0 PSIG
		Silver	0.8 PSIG	2.5 PSIG	1.2 PSIG	2.2 PSIG
		Yellow	1.7 PSIG	4.9 PSIG	2.4 PSIG	4.4 PSIG
		Red	1.7 PSIG	6.1 PSIG*	2.5 PSIG	5.4 PSIG*

**SPRING DATA, SPRING COLOR OUTLET PRESSURE RANGE, MODELS B838 IMN AND IMR**

		B838IMN Adjusted Outlet Pressure Range		B838IMR Adjusted Outlet Pressure Range		
<i>Spring adjustment ferrule at min. and max. depths</i>						
Orifice size	Inlet pressure	Spring color	Outlet pressure			
			Minimum	Maximum	Minimum	Maximum
1"	10 PSIG	Orange	3.3" w.c.	6.0" w.c.	3.3" w.c.	4.6" w.c.
		Brown	3.4" w.c.	7.6" w.c.	4.6" w.c.	7.2" w.c.
		Green/white	4.7" w.c.	9.5" w.c.	5.9" w.c.	8.8" w.c.
		Black	4.9" w.c.	14.7" w.c.	7.0" w.c.	13.3" w.c.
		Purple	13.5" w.c.	23.5" w.c.	14" w.c.	21.8" w.c.
		Blue	0.3 PSIG	1.1 PSIG	0.5 PSIG	1.0 PSIG
		Silver	0.8 PSIG	2.4 PSIG	1.1 PSIG	2.2 PSIG
		Yellow	1.6 PSIG	4.8 PSIG	2.2 PSIG	4.2 PSIG
		Red	1.7 PSIG	6.0 PSIG*	2.3 PSIG	5.3 PSIG*

\*Maximum allowable outlet pressure is 5.00 PSIG

Note

Spring Ranges are approximate and may vary by application.

**ORIFICE DATA, WIDE OPEN FLOW COEFFICIENTS AND MAXIMUM PRESSURE DATA**

Orifice Size (inches)	K factors	Maximum Operating Inlet Pressure R Models		Max Emergency Inlet Pressure	Max. Emergency Outlet Pressure (containment)	
		in. w.c. delivery	PSIG delivery	All Outlet	in. w.c. delivery	PSIG delivery
		Pressure PSIG	Pressure PSIG	Inlet Pressure PSIG		
3/8	600	125	175	300	30	30
1/2	900	125	175	300		
5/8	1230	60	150	300		
3/4	1640	60	150	300		
1	2290	30	100	175		
1-1/4	2925	40	75	125		
1-3/8	3500	25	50	100		
Orifice Size (inches)	K factors	Maximum Operating Inlet IMN and IMR Models		Max Emergency Inlet Pressure	Max. Emergency Outlet Pressure (containment)	
		in. w.c. delivery	PSIG delivery	All Outlet	in. w.c. delivery	PSIG delivery
		Pressure PSIG	Pressure PSIG	Inlet Pressure PSIG		
3/8	600	125	125	300	30	30
1/2	810	125	125	300		
5/8	1175	60	60	300		
3/4	1480	60	60	300		
1	1950	30	30	170		

## OPERATING TEMPERATURE

- 20°F to 150°F

## ADDITIONAL SPECIFICATIONS

<b>Available pilot vent sizes</b>	1" NPT on non-internal relief (N) models only.
	2-1/2" NPT (standard) on internal relief (R) models only.
	2" NPT (optional) <b>Warning</b> The 2" relief size will reduce relief capacity.
<b>Loading ring position</b>	For outlet pressure >1 PSIG: 0°.
	For outlet pressure < 1 PSIG: varies.
<b>Other available options</b>	Seal wire to indicate unapproved tampering.
	1/8" pipe plug tap on upstream side of valve body.

## CONSTRUCTION

Itron takes pride in delivering products with the utmost concern for safety, quality, and customer satisfaction.

### Material construction:

Valve bodies	High tensile strength cast iron (ASTM A-126, Class A)
Orifices	Aluminum
Valve seats	Buna-N
Valve stems	Nylon
Lever pins	Stainless steel (type 303)
Levers	Zinc and dichromate plated steel (AISI C1010)
Upper diaphragm plates	Zinc and dichromate plated steel (14-gauge steel)
Lower diaphragm plates	Die cast aluminum (ASTM B-85 Alloy SC84A)
Diaphragms	Buna-N reinforcing fiber
Vent valves/seats	Neoprene
Vent screen	Stainless steel (16 mesh)
Adjustment ferrules	Acetal
Seal caps	ABS plastic
Diaphragm cases	Die cast aluminum (ASTM B85, Alloy SC84A)
Valve stem inserts	Acetal

## VALVE BODY SIZES

Inlet	Outlet	NPT	Flanged
2"	2"	X	X
2"	3"		X
2"	4"		X

X indicates the valve body is available in that configuration.



## CORRECTION FACTORS FOR NON-NATURAL GAS APPLICATIONS

The B838 may be used to control gases other than natural gas. To determine the capacity for gases other than natural gas, multiply the values within the capacity tables by a correction factor. The table below lists the correction factors for some of the more common gases.

Gas Type	Specific Gravity	Correction Factor (CF)
Air	1.00	0.77
Butane	2.01	0.55
Carbon Dioxide (Dry)	1.52	0.63
Carbon Monoxide (Dry)	0.97	0.79
Natural Gas	0.60	1.00
Nitrogen	0.97	0.79
Propane	1.53	0.63
Propane-Air-Mix	1.20	0.71

To calculate the correction factor for gases not listed in the table above, use the gases' specific gravity and insert it in the formula listed below:

$$\sqrt{\frac{SG_1}{SG_2}}$$

Correction Factor (CF) =

Where:  $SG_1$  = Specific gravity of the gas in which the capacity is published.

$SG_2$  = Specific gravity of the gas to be controlled.

## Wide Open Flow Calculations

For wide-open orifice flow calculations use the following equations:

For  $\frac{P_1}{P_2} < 1.89$  use:  $Q = K\sqrt{P_2(P_1 - P_2)}$

For  $\frac{P_1}{P_2} > 1.89$  use:  $Q = \frac{KP_1}{2}$

Where:  $P_1$  = Absolute Inlet Pressure (PSIA)

$P_2$  = Absolute Outlet Pressure (PSIA)

$Q$  = Flow Rate (SCFH)

$K$  = Orifice Coefficient (SCFH/PSI)

**B838 R, N, D, M TWIN PARALLEL FLOW SERVICE REGULATOR CAPACITY TABLE, 2" X 2"**

Outlet Pressure		7" w.c.	7" w.c.	11" w.c.	11" w.c.	1 PSIG	2 PSIG	2 PSIG	2 PSIG	5 PSIG	5 PSIG	5 PSIG
Pressure Droop		1" w.c.	1" w.c.	2" w.c.	2" w.c.	0.2 PSIG	1% ABS	2% ABS	WO	1% ABS	2% ABS	WO
Orifice Size (in inches)	Inlet Pressure PSIG	Flow rate, SCFH of .60 Wp. Gr. gas @ 14.7 PSIA and 60°F										
		Loading Ring Setting										
		0°		0°		0°	0°	0°	0°	0°	0°	0°
1-1/4  K = 2925	1	4750		5350								
	2	6400		7200		6900						
	3	8500		9200		9200	3800	6200	11950			
	5	11500	N.C.	11750	N.C.	12100	5600	8500	20705			
	10	18000		16000		18000	9300	14000	33785	5200	8000	29015
	15	20000		20000		20000	11700	16300	43085	7000	10900	41040
	25	20000		20000		20000	17400	20000	58060	9500	15200	58060
		0°	29°	0°	25°	0°	0°	0°	0°	0°	0°	0°
1  K = 2290	1	4000	3200	3750	3200							
	2	5950	5000	6000	5100	5550						
	3	7300	6000	7600	6500	8450	3300	5550	9355			
	5	10900	7800	10650	8700	10950	4550	7950	16210			
	10	15100	11600	15000	13000	15100	7450	12000	26450	3850	5750	22715
	15	20000	17400	20000	19000	20000	9700	14700	33730	5200	8000	32130
	25		20000		20000	20000	15800	19800	45455	8750	13500	45455
45		20000		20000	20000	20000	20000	68355	12500	18100	68355	
		0°	32°	0°	32°	0°	0°	0°	0°	0°	0°	0°
3/4  K = 1640	1	3000	2850	2500	2350							
	2	3750	3400	4200	4050	4000						
	3	5150	4400	5500	5250	6200	2750	4150	6700			
	5	7800	6100	8300	7650	7900	4000	6500	11610			
	10	11250	10600	11700	10500	12600	6400	10000	18940	3850	5500	16270
	15	15250	13900	15700	13500	15800	8500	13200	24155	4800	7400	23010
	25		19000		20000	20000	12000	17200	32555	8100	12000	32555
60		20000		20000	20000	20000	20000	61255	14800	20000	61255	
		0°	36°	0°	36°	0°	0°	0°	0°	0°	0°	0°
5/8  K = 1230	1	2000	1850	2000	2050							
	2	3500	2900	3250	3200	2800						
	3	4750	3500	4400	4250	3800	2450	3700	5025			
	5	6700	5150	6450	5850	5600	3500	5250	5705			
	10	9800	7400	10200	9300	5700	5800	8600	14205	3150	4600	12200
	15	12900	9850	13350	11000	11500	7500	11100	18120	4100	6000	17225
	25		14000		16100	17000	11300	15300	24415	6200	9400	24415
60		20000		20000	20000	20000	19100	20000	45940	12750	18150	45940
75		20000		20000	20000	20000	20000	55165	14300	20000	55165	

N.C. No change needed in loading ring setting.

K factors are wide open.

**B838 R, N, D, M TWIN PARALLEL FLOW SERVICE REGULATOR CAPACITY TABLE, 2" X 2"**

Outlet Pressure		7" w.c.	7" w.c.	11" w.c.	11" w.c.	1 PSIG	2 PSIG	2 PSIG	2 PSIG	5 PSIG	5 PSIG	5 PSIG	
Pressure Drop		1" w.c.	1" w.c.	2" w.c.	2" w.c.	0.2 PSIG	1% ABS	2% ABS	WO	1% ABS	2% ABS	WO	
Orifice Size (in inches)	Inlet Pressure PSIG	Flow rate, SCFH of .60 Wp. Gr. gas @ 14.7 PSIA and 60°F											
		Loading Ring Setting											
Loading Ring Setting		0°	36°	0°	40°	0°	0°	0°	0°	0°	0°	0°	
1/2	K = 900	1	1600	1550	1500	1450							
		2	2500	2300	2300	2250	2350						
		3	3500	3000	3400	3200	3200	1850	2600	3670			
		5	5000	3800	4800	4450	4300	2950	4000	6370			
		10	8700	6000	7550	6700	7000	4600	7050	10395	2650	3250	8930
		15	10100	7300	9800	8000	9300	6800	8750	13255	3700	5000	12625
		25	12250	10500	13100	10800	12800	10400	13400	17865	5400	7550	17865
		75				20000	20000	20000	20000	40365	13000	18700	40365
Loading Ring Setting		0°	25°	0°	32°	0°	0°	0°	0°	0°	0°	0°	
3/8	K = 600	1	1400	1400	1400	1300							
		2	2150	1850	2150	2050	1850						
		3	2750	2450	2700	2450	2450	1350	2050	2800			
		5	3600	3400	3450	3400	3450	2350	3000	4250			
		10	5400	4900	5300	4700	5050	3400	4450	6930	2050	2650	5950
		15	6850	5900	6650	5950	6650	4400	6250	8840	2700	3550	8420
		25	10200	8500	10100	8300	9500	6400	8900	11910	3600	5000	11910
		60		15300	18300	15400	18300	13200	17800	22410	6500	10600	22410
		75		17400		17700	20000	14900	19800	26910	7400	12200	26910
		100		20000		20000	20000	17300	20000	34410	9800	15300	34410
125		20000		20000	20000	20000	20000	41910	11300	20000	41910		

K factors are wide open.

**B838 R, N, D, M TWIN PARALLEL FLOW SERVICE REGULATOR CAPACITY TABLE, 2" X 3"**

Outlet Pressure		7" w.c.	7" w.c.	11" w.c.	11" w.c.	1 PSIG	2 PSIG	2 PSIG	2 PSIG	5 PSIG	5 PSIG	5 PSIG
Pressure Droop		1" w.c.	1" w.c.	2" w.c.	2" w.c.	0.2 PSIG	1% ABS	2% ABS	WO	1% ABS	2% ABS	WO
Orifice Size (in inches)	Inlet Pressure PSIG	Flow rate, SCFH of .60 Wp. Gr. gas @ 14.7 PSIA and 60°F										
		0°	40°	0°	43°	0°	0°	0°	0°	0°	0°	0°
<b>Loading Ring Setting</b>		<b>0°</b>	<b>40°</b>	<b>0°</b>	<b>43°</b>	<b>0°</b>	<b>0°</b>	<b>0°</b>	<b>0°</b>	<b>0°</b>	<b>0°</b>	<b>0°</b>
1-1/4 K = 3400	1	5600	5400	5450	5650							
	2	9600	8450	8800	8500	7800						
	3	13200	11000	11600	11000	11800	5500	8000	13890			
	5	18900	17400	16700	16100	17000	9100	12900	24065			
	10		29100	28000	26200	27700	15600	22200	39270	5500	8600	33730
	15		38500	37100	34500	36500	22300	33400	50080	7300	11700	47700
	25		40000		40000	40000	39500	40000	67490	13100	23200	67490
	30		40000		40000	40000	40000	40000	75990	18000	27400	75990
<b>Loading Ring Setting</b>		<b>0°</b>	<b>46°</b>	<b>0°</b>	<b>43°</b>	<b>0°</b>	<b>0°</b>	<b>0°</b>	<b>0°</b>	<b>0°</b>	<b>0°</b>	<b>0°</b>
1 K = 2900	1	4450	3800	4400	4200							
	2	7300	6500	7400	7200	6500						
	3	10650	8500	10300	9000	9300	5100	6800	11850			
	5	16400	14400	14800	12200	13650	7100	10600	20525			
	10	23800	23000	23300	19600	22500	12600	18500	33495	4900	7600	28770
	15		29900	30100	26500	29200	17100	23000	42715	6600	10100	40685
	25		40000		40000	40000	28800	39000	57565	11500	18400	57565
	45		40000		40000	40000	40000	40000	86565	21200	34000	86565
<b>Loading Ring Setting</b>		<b>0°</b>	<b>46°</b>	<b>0°</b>	<b>45°</b>	<b>0°</b>	<b>0°</b>	<b>0°</b>	<b>0°</b>	<b>0°</b>	<b>0°</b>	<b>0°</b>
3/4 K = 2000	1	3500	3100	3100	2900							
	2	5500	4500	5000	4750	4300						
	3	7500	6400	7050	6450	6450	4100	6000	8170			
	5	13100	10200	11850	9200	10200	5900	8250	14155			
	10	19000	18100	19700	17000	17050	9600	13700	23100	3700	6050	19840
	15	26500	25250	26400	23700	23800	13200	19800	29460	5300	8500	28060
	25		40000		38000	38200	23900	32000	39700	8400	13800	39700
	60		40000		40000	40000	40000	40000	74700	20200	35500	74700
<b>Loading Ring Setting</b>		<b>0°</b>	<b>48°</b>	<b>0°</b>	<b>43°</b>	<b>0°</b>	<b>0°</b>	<b>0°</b>	<b>0°</b>	<b>0°</b>	<b>0°</b>	<b>0°</b>
5/8 K = 1450	1	2300	2100	2200	2100							
	2	3950	3200	3700	3500	3000						
	3	5600	4300	5000	4750	4550	3400	4650	5925			
	5	7350	6100	7550	6500	6100	4900	6650	10265			
	10	14200	11800	14400	12000	11950	7200	10900	16750	3200	4800	14385
	15	20400	17400	20000	17000	16000	11300	14000	21360	4850	7100	20345
	25		28850	34300	29100	27450	14400	22000	28785	7200	11100	28785
	60		40000		40000	40000	34000	40000	54160	16800	24600	54160
75		40000		40000	40000	40000	40000	65035	19800	32000	65035	

**B838 R, N, D, M TWIN PARALLEL FLOW SERVICE REGULATOR CAPACITY TABLE, 2" X 3"**

Outlet Pressure		7" w.c.	7" w.c.	11" w.c.	11" w.c.	1 PSIG	2 PSIG	2 PSIG	2 PSIG	5 PSIG	5 PSIG	5 PSIG	
Pressure Drop		1" w.c.	1" w.c.	2" w.c.	2" w.c.	0.2 PSIG	1% ABS	2% ABS	WO	1% ABS	2% ABS	WO	
Orifice Size (in inches)	Inlet Pressure PSIG	Flow rate, SCFH of .60 Wp. Gr. gas @ 14.7 PSIA and 60°F											
		Loading Ring Setting											
Loading Ring Setting		0°	48°	0°	45°	0°	0°	0°	0°	0°	0°	0°	
1/2	K = 1100	1	1650	1550	1500	1450							
		2	2500	2300	2650	2250	2450						
		3	3500	3000	3750	3500	3600	2800	3800	4495			
		5	5450	4400	6000	4650	5100	4450	4700	7785			
		10	10500	6850	8900	7450	7550	6050	7200	12705	2850	4100	10910
		15	13800	8500	12100	11100	11100	7800	11100	16205	3800	5300	15435
		25	21000	16600	19700	17600	17400	13000	17300	21835	5800	8800	21835
		75		36600		38800	68400	28000	33000	41085	12100	18800	41085
			40000		40000	40000	35000	40000	49335	17500	24400	49335	
Loading Ring Setting		0°	25°	0°	32°	0°	0°	0°	0°	0°	0°	0°	
3/8	K = 600	1	1400		1400								
		2	2150		2150		1850						
		3	2800		2700		2450	1700	2050	2800			
		5	3700		3650		3450	2600	3200	4250			
		10	5900		5800		5050	3900	5200	6930	2200	3000	5950
		15	7450	N.C.	7300	N.C.	6650	5200	6650	8840	3000	4100	8420
		25	10900		10500		9500	8600	10750	11910	4300	6100	11910
		60	21400		21400		19000	19200	20600	22410	8000	12600	22410
		75	26000		26000		25400	24800	26200	26910	10800	17100	26910
		100	30000		30000		29800	26400	28500	34410	12000	19000	34410
125	35000		35000		34700	31200	34600	41910	15700	23000	41910		

N.C. No change needed in loading ring setting.

K factors are wide open.

**B838 R, N, D, M TWIN PARALLEL FLOW SERVICE REGULATOR CAPACITY TABLE, 2" X 4"**

Outlet Pressure		7" w.c.	7" w.c.	11" w.c.	11" w.c.	1 PSIG	2 PSIG	2 PSIG	2 PSIG	5 PSIG	5 PSIG	5 PSIG
Pressure Droop		1" w.c.	1" w.c.	2" w.c.	2" w.c.	0.2 PSIG	1% ABS	2% ABS	WO	1% ABS	2% ABS	WO
Orifice Size (in inches)	Inlet Pressure PSIG	Flow rate, SCFH of .60 Wp. Gr. gas @ 14.7 PSIA and 60°F										
		0°	30°	0°	32°	0°	0°	0°	0°	0°	0°	0°
<b>Loading Ring Setting</b>		<b>0°</b>	<b>30°</b>	<b>0°</b>	<b>32°</b>	<b>0°</b>	<b>0°</b>	<b>0°</b>	<b>0°</b>	<b>0°</b>	<b>0°</b>	<b>0°</b>
1-1/4 K = 3400	1		6000	6000	5500							
	2		10300	10900	9500	8850						
	3		14800	14100	13000	13300	5750	8400	14300			
	5	N.C.	21000	20000	17500	19000	9550	13600	24775			
	10		34000		31000	32600	16400	23350	40425	5600	10000	34720
	15		45600		42000	44000	23450	35150	51555	7500	13500	49105
	25		58000		54000	56000	47000	58500	69475	13400	23500	69475
	30		75000		74000	74000	69700	74000	95725	19000	28200	95725
<b>Loading Ring Setting</b>		<b>0°</b>	<b>40°</b>	<b>0°</b>	<b>46°</b>	<b>0°</b>	<b>0°</b>	<b>0°</b>	<b>0°</b>	<b>0°</b>	<b>0°</b>	<b>0°</b>
1 K = 2900	1	5100	5550	5450	4500							
	2	8350	8150	8250	7500	6850						
	3	11500	11400	11000	10050	9900	5350	7150	12260			
	5	17600	17400	15600	14300	14200	7450	11150	21235			
	10	31200	31000	30900	28400	28200	13250	19450	34650	5050	7850	29760
	15		44000	43900	40300	4000	18000	27500	44190	6800	10400	42090
	25		52000		51600	51300	34000	45000	59550	11850	18950	59550
	45		80000		80000	80000	75000	80000	112050	29000	29000	112050
<b>Loading Ring Setting</b>		<b>0°</b>	<b>40°</b>	<b>0°</b>	<b>46°</b>	<b>0°</b>	<b>0°</b>	<b>0°</b>	<b>0°</b>	<b>0°</b>	<b>0°</b>	<b>0°</b>
3/4 K = 2000	1	4050	3950	3950	3500							
	2	6000	5700	5800	5650	5100						
	3	8000	7950	7900	7600	6900	4300	6300	8580			
	5	14200	12100	14000	12000	11800	6200	8650	14865			
	10	19500	18800	21600	19000	19200	10100	14400	24255	3800	6200	20835
	15		27600		27600	27600	13900	20850	30935	5450	8750	29465
	25		39400		39400	39400	25150	33700	41685	8650	14200	41685
	60		65000		65000	65000	62000	67000	78435	21900	39000	78435
<b>Loading Ring Setting</b>		<b>0°</b>	<b>40°</b>	<b>0°</b>	<b>40°</b>	<b>0°</b>	<b>0°</b>	<b>0°</b>	<b>0°</b>	<b>0°</b>	<b>0°</b>	<b>0°</b>
5/8 K = 1450	1	3000	2900		3300							
	2	4900	4300		5400	3600						
	3	6350	6100		6700	5700	3650	5050	6730			
	5	9450	9100		10700	7700	5300	7200	10795			
	10	15800	15500	N.C.	17600	14600	7800	11800	17615	3300	4950	15130
	15	22000	18100		22750	19400	12000	14900	22465	5000	7300	21395
	25	30200	29000		30200	30200	14900	23800	30270	7400	11450	30270
	60		44100		46500	46500	37000	51500	56960	17300	28300	56960
75		52800		54000	54000	54000	54000	68395	25350	36000	68395	

**B838 R, N, D, M TWIN PARALLEL FLOW SERVICE REGULATOR CAPACITY TABLE, 2" X 4"**

Outlet Pressure		7" w.c.	7" w.c.	11" w.c.	11" w.c.	1 PSIG	2 PSIG	2 PSIG	2 PSIG	5 PSIG	5 PSIG	5 PSIG
Pressure Droop		1" w.c.	1" w.c.	2" w.c.	2" w.c.	0.2 PSIG	1% ABS	2% ABS	WO	1% ABS	2% ABS	WO
Orifice Size (in inches)	Inlet Pressure PSIG	Flow rate, SCFH of .60 Wp. Gr. gas @ 14.7 PSIA and 60°F										
		0°	46°	0°	46°	0°	0°	0°	0°	0°	0°	0°
<b>Loading Ring Setting</b>		<b>0°</b>	<b>46°</b>	<b>0°</b>	<b>46°</b>	<b>0°</b>	<b>0°</b>	<b>0°</b>	<b>0°</b>	<b>0°</b>	<b>0°</b>	<b>0°</b>
1/2  K = 1100	1	2250	2100	2100	2050							
	2	3500	3550	3500	3400	3000						
	3	4900	4550	4500	4500	4150	2900	3900	4905			
	5	7000	6350	6400	6200	6100	4700	6000	8495			
	10	11350	10700	10400	10150	9900	6650	9050	13860	2950	4250	11905
	15	14000	13900	13500	13300	12900	8750	12500	17675	3600	5450	16835
	25		21500	21000	20800	19400	14750	19600	23820	6000	9100	23820
	60		43500		41400	38500	34800	43500	44820	12500	19400	44820
75		50600		49200	48000	42000	50500	53820	18050	25150	53820	
<b>Loading Ring Setting</b>		<b>0°</b>	<b>25°</b>	<b>0°</b>	<b>32°</b>	<b>0°</b>	<b>0°</b>	<b>0°</b>	<b>0°</b>	<b>0°</b>	<b>0°</b>	<b>0°</b>
3/8  K = 600	1	1400		1400								
	2	2200		2250		2000						
	3	2800		2800		2650	1700	2050	2800			
	5	3850		4050		3800	2600	3200	4250			
	10	6350		6350		6000	3900	5200	6930	2200	3000	5950
	15	8150	N.C.	8150	N.C.	7750	5200	6650	8840	3000	4100	8420
	25	11100		11100		10600	8600	10750	11910	4300	6100	11910
	60	22000		22000		21200	19200	20600	22410	8000	12600	22410
	75	26000		26000		25400	24800	26200	26910	10800	17100	26910
	100	30000		30000		29800	28000	28700	34410	12000	19000	34410
125	35000		35000		34700	34000	35100	41910	15700	23000	41910	

N.C. No change needed in loading ring setting.

K factors are wide open.

## CL838 PERFORMANCE DATA

### 7" w.c. Set Point

Type and model	B838
Inlet size	2" Flanged
Outlet size	4" Flanged
Orifice size	1-1/4"

All test results are reported at a base of 14.7 PSIG at 60° F and with 0.6 S.G. gas.

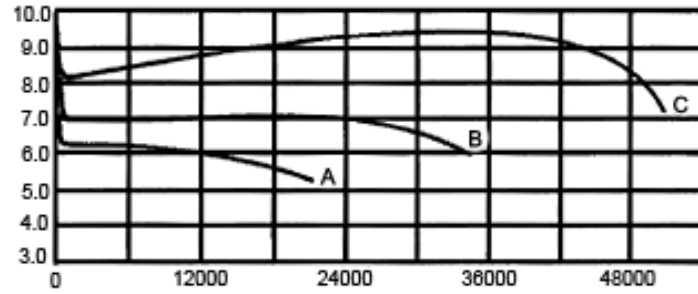

### B838 RELIEF CURVES

#### 7" w.c. Set Point

Type and model	B838
Inlet size	2" Flanged
Outlet size	4" Flanged

All test results are reported at a base of 14.7 PSIG at 60° F and with 0.6 S.G. gas.

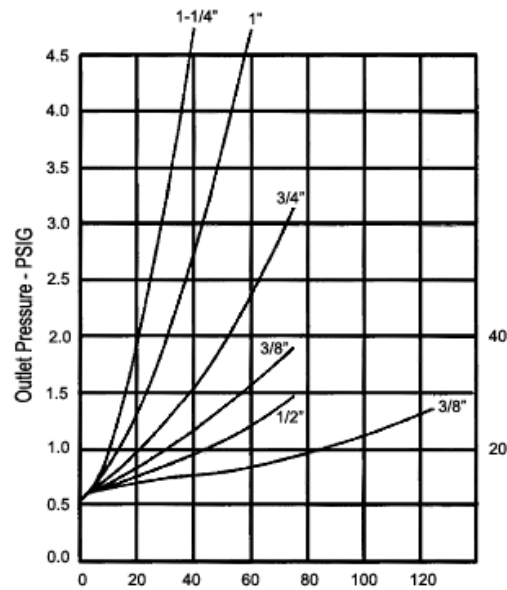

#### 1 PSIG Set Point

Type and model	B838
Inlet size	2" Flanged
Outlet size	4" Flanged

All test results are reported at a base of 14.7 PSIG at 60° F and with 0.6 S.G. gas.

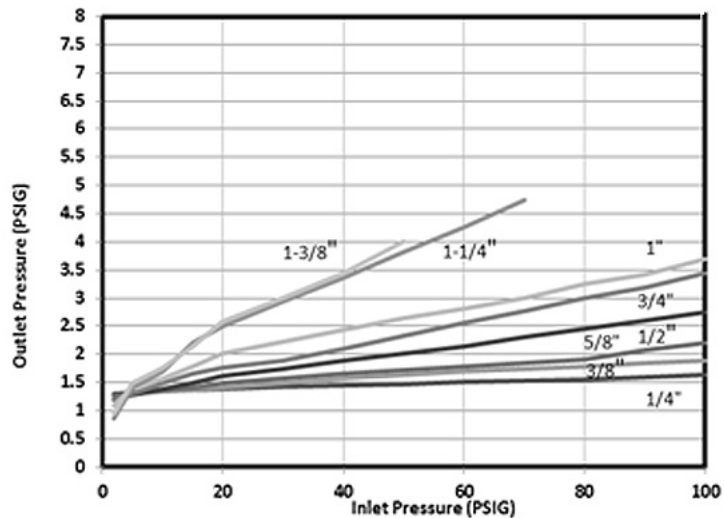



## B838 RELIEF CURVES

### 2 PSIG Set Point

Type and model	B838
Inlet size	2" Flanged
Outlet size	4" Flanged
Orifice size	1-1/4"

All test results are reported at a base of 14.7 PSIG at 60° F and with 0.6 S.G. gas.

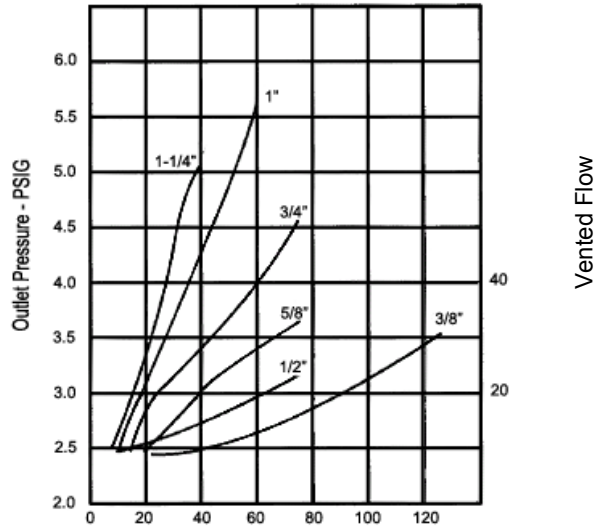

### 5 PSIG Set Point

Type and model	CL838
Inlet size	2" Flanged
Outlet size	4" Flanged
Orifice size	1-1/4"

All test results are reported at a base of 14.7 PSIG at 60° F and with 0.6 S.G. gas.

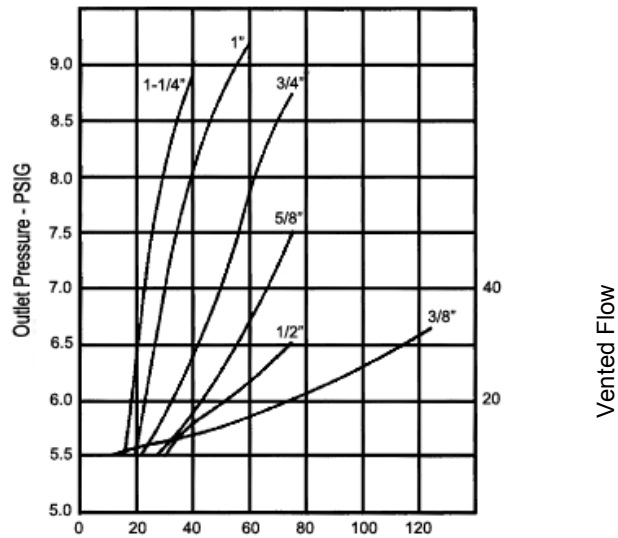

**B838 MONITOR SPECIFICATION 2" X 2"**

Orifice Size (inches)	Inlet Pressure PSIG	Capacity, SCFH								
		Drop in pressure across orifice, PSIG								
		0.1	0.2	0.3	0.4	0.5	1.0	2.0	3.0	5.0
1-1/4 K = 2925	1	3650	5100	6250	7200	8050				
	2	3750	5300	6450	7450	8300	11500			
	3	3850	5450	6650	7650	8550	11900	16300		
	5	4050	5750	7000	8100	9050	12600	17400	20700	
	8	4350	6200	7550	8700	9700	13600	18800	22400	27500
	10	4550	6450	7900	9100	10100	14200	19700	23500	29000
	15	5000	7100	8650	10000	11100	15600	21700	26100	32500
	25	5800	8200	10000	11500	12900	18100	25300	30600	38500
	35	6500	9200	11200	12900	14500	20400	28500	34600	43700
	50	7400	10500	12800	14800	16500	23300	32700	39700	50500
	75	8750	12300	15100	17400	19500	27500	38700	47100	60100
100	9900	13900	17100	19700	22000	31100	43900	53500	68500	
1 K = 2290	1	2850	4000	4900	5650	6300				
	2	2950	4150	5050	5800	6500	9050			
	3	3000	4250	5200	6000	6700	9350	12800		
	5	3200	4500	5500	6350	7050	9900	13600	16200	
	8	3400	4850	5900	6800	7600	10600	14700	17600	21500
	10	3550	5050	6150	7100	7950	11100	15400	18400	22700
	15	3900	5550	6800	7800	8750	12200	17000	20400	25400
	25	4550	6400	7850	9050	10100	14200	19800	24000	30100
	35	5100	7200	8800	10100	11300	15900	22300	27100	34200
	50	5800	8200	10000	11600	12900	18200	25600	31100	39500
	75	6850	9650	11800	13600	15200	21500	30300	36900	47100
100	7750	10900	13400	15400	17300	24400	34300	41900	53600	
3/4 K = 1640	1	2050	2875	3500	4050	4500				
	2	2100	2975	3600	4150	4650	6450			
	3	2150	3050	3700	4300	4800	6700	9150		
	5	2275	3200	3950	4550	5050	7050	9750	11600	
	8	2450	3450	4250	4850	5450	7600	10500	12600	15400
	10	2550	3600	4400	5100	5700	7950	11000	13200	16200
	15	2800	3950	4850	5600	6250	8750	12200	14600	18200
	25	3250	4600	5600	6500	7250	10200	14200	17200	21600
	35	3650	5150	6300	7250	8100	11400	16000	19400	24500
	50	4150	5850	7200	8300	9250	13000	18300	22300	28300
	75	4900	6900	8450	9800	10900	15400	21700	26400	33700
100	5550	7800	9600	11000	12300	17400	24600	30000	38400	

K-factors are wide open.

**B838 MONITOR SPECIFICATIONS 2" X 3"**

Orifice Size (inches)	Inlet Pressure PSIG	Capacity, SCFH								
		Drop in pressure across orifice, PSIG								
		0.1	0.2	0.3	0.4	0.5	1.0	2.0	3.0	5.0
1-1/4 K = 3400	1	4200	5950	7300	8400	9350				
	2	4350	6150	7500	8650	9650	13400			
	3	4500	6350	7750	8900	9950	13800	19000		
	5	4750	6700	8200	9400	10500	14700	20200	24000	
	8	5100	7200	8800	10100	11300	15800	21800	26100	31900
	10	5300	7500	9150	10600	11800	16500	22900	27400	33700
	15	5850	8250	10000	11600	12900	18200	25300	30400	37700
	25	6750	9550	11600	13400	15000	21100	29500	35600	44700
	35	7550	10600	13000	15000	16800	23700	33200	40200	50800
	50	8600	12200	14900	17200	19200	27100	36000	46200	58700
	75	10100	14300	17600	20300	22700	32000	45000	54800	69900
100	11500	16200	19900	22900	25600	36200	51000	62200	79600	
1 K = 2900	1	3600	5100	6200	7150	7950				
	2	3700	5250	6400	7400	8250	11400			
	3	3800	5400	6600	7600	8500	11800	16200		
	5	4050	5700	6950	8050	8950	12500	17200	20500	
	8	4350	6150	7500	8650	9650	13500	18600	22200	27200
	10	4500	6400	7600	9000	10000	14100	19500	23300	28700
	15	4950	7000	8600	9900	11000	15500	21500	25900	32200
	25	5750	8150	9950	11400	12800	18000	25100	30400	38100
	35	6450	9100	11100	12800	14300	20200	28300	34300	43300
	50	7350	10400	12700	14700	16400	23100	32400	39400	50100
	75	8650	12200	15000	17300	19300	27300	38400	46700	59600
100	9800	13800	16900	19600	21900	30900	43500	53000	67900	
3/4 K = 2000	1	2475	3500	4250	4900	5500				
	2	2575	3600	4400	5100	5650	7900			
	3	2650	3700	4550	5250	5850	8150	11200		
	5	2800	3900	4800	5650	6150	8600	11800	14100	
	8	3000	4200	5150	5950	6650	9300	12800	15300	18800
	10	3100	4400	5400	6200	6950	9700	13400	16100	19800
	15	3400	4850	5900	6800	7600	10700	14800	17800	22200
	25	3950	5600	6850	7900	8850	12400	17300	20900	26300
	35	4450	6250	7650	8850	9900	13900	19500	23600	29800
	50	5050	7150	8750	10100	11300	15900	22300	27200	34500
	75	5950	8450	10300	11900	13300	18800	26400	32200	41100
100	6750	9550	11700	13500	15100	21300	30000	36600	46800	

K-factors are wide open.

**B838 MONITOR SPECIFICATIONS 2" X 4"**

Orifice Size (inches)	Inlet Pressure PSIG	Capacity, SCFH								
		Drop in pressure across orifice, PSIG								
		0.1	0.2	0.3	0.4	0.5	1.0	2.0	3.0	5.0
1-1/4 K = 3500	1	4350	6150	7500	8650	9600				
	2	4500	6300	7750	8900	9900	13800			
	3	4600	6500	7950	9200	10200	14300	19600		
	5	4850	6900	8400	9700	10800	15100	20800	24700	
	8	5200	7400	9000	10400	11600	16300	22400	26800	32800
	10	5450	7700	9400	10900	12100	17000	23500	28100	34600
	15	6000	8450	10300	11900	13300	18700	26000	31200	38800
	25	6950	9800	12000	13800	15400	21700	30300	36600	45900
	35	7750	11000	13400	15500	17300	24400	34100	41300	52200
	50	8850	12500	15300	17700	19800	27900	39100	47500	60300
	75	10400	14700	18100	20900	23300	32100	46300	56300	71900
100	11800	16700	20500	23600	26400	37300	52500	63900	81800	
1 K = 3000	1	3700	5250	6400	7400	8250				
	2	3850	5400	6600	7600	8500	11800			
	3	3950	5600	6800	7850	8750	12200	16800		
	5	4150	5900	7200	8300	8250	12900	17800	21200	
	8	4500	6350	7750	8900	9950	13900	19250	23000	28100
	10	4650	6600	8100	9300	10400	14600	20200	24100	29700
	15	5150	7250	8900	10200	11400	16000	22300	26800	33200
	25	5950	8400	10300	11800	13200	18600	26000	31400	39400
	35	6650	9400	11500	13300	14800	20900	29200	35400	44800
	50	7600	10700	13100	15200	16900	23900	33500	40700	51700
	75	8950	12600	15500	17900	20000	28200	39700	48300	61600
100	10100	14300	17500	20200	22600	31900	45000	54800	70200	
3/4 K = 2100	1	2600	3650	4500	5150	5750				
	2	2700	3800	4650	5350	5950	8300			
	3	2750	3900	4750	5500	6150	8550	11700		
	5	2900	4100	5050	5800	6500	9050	12400	14800	
	8	3150	4450	5400	6250	6950	9750	13500	16100	19700
	10	3250	4600	5650	6500	7300	10200	14100	16900	20800
	15	3600	5050	6200	7150	8000	11200	15600	18700	23300
	25	4150	5900	7200	8300	9250	13000	18200	22000	27600
	35	4650	6600	8050	9300	10400	14600	20500	24800	31300
	50	5300	7500	9200	10600	11800	16700	23500	28500	36200
	75	6250	8850	10800	12500	14000	19700	27600	33800	43100
100	7100	10000	12300	14100	15800	22300	31400	38400	49100	

K-factors are wide open.

## PRINCIPLE OF OPERATION

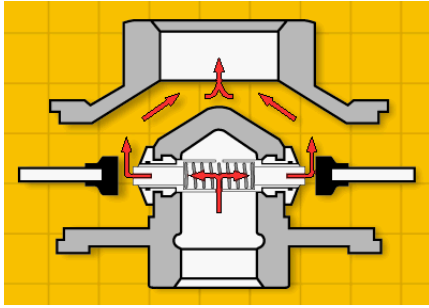

A. Normal regulation

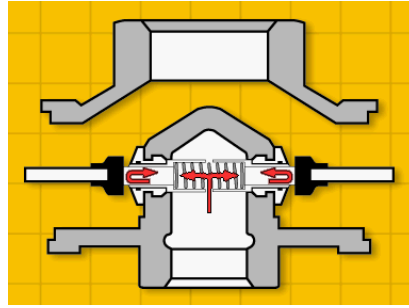

B. Normal lock-up

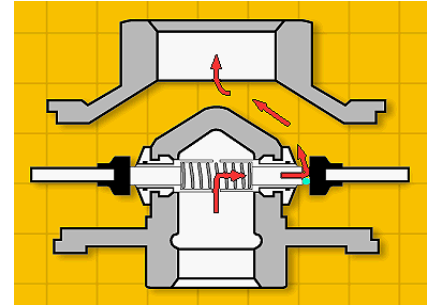

C. Dual monitor operation, internal foreign material failure

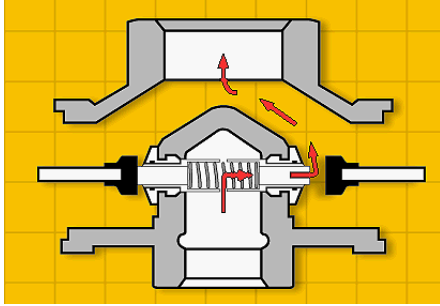

D. Single monitor operation, full internal diaphragm case failure

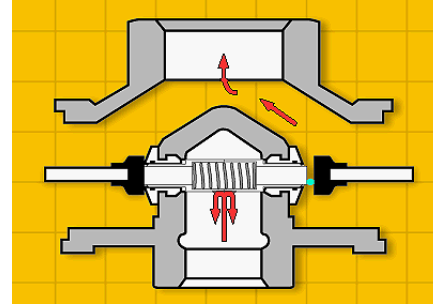

E. Total lock-up

## PRINCIPLE OF OPERATION

**A. Normal regulation.** The internal monitor orifice operates like a standard one-piece orifice, performing normal regulation.

**B. Normal lock-up.** The regulator is free to lock-up in the usual manner. The O-ring seal prevents gas from leaking past the orifice exterior into the downstream or low pressure side of the valve body.

**C. Dual monitor operation, internal foreign material failure.** If the regulator fails to lock-up for any reason, the internal monitor orifice automatically goes into operation. Outlet pressure increases slightly, causing the valve seat to push against the inner or sliding part of the orifice gradually compressing the monitor spring and closing the secondary or monitor orifice on the inlet side of the sliding orifices. At this point, the B838-IM functions as a monitor regulator. For example, assume a weld bead is caught between the orifice and the valve seat while the regulator is in high-flow operation. If the flow reduces, the valve tries to close but can't due to the foreign matter. The outlet pressure increases approximately 2" w.c. above the original set point which starts to close the secondary monitor orifice. If the gas demand is decreased, the monitor orifice will partially close and become the new operating orifice. The new orifice will function as a monitor regulator and keep the outlet pressure approximately 3" above the set pressure on inches water column, or .8 PSIG when set for PSIG outlet. If the flow becomes further reduced to no-flow, then the sliding orifice (or orifices) close against the secondary rubber seat providing a complete no-gas flow with a total outlet pressure build-up of only 6" w.c. above the original set point.

**D. Single monitor operation, one full internal diaphragm case failure.** If the diaphragm case is damaged on one side of the piping such that the lever and valve seat cannot move to close against the orifice face, the outlet pressure builds (as described in C) on the good regulator and its sliding orifice moves to contact the non-movable failed orifice monitor seat. Closing or lock-up will be restricted according to flow demand. Since only one diaphragm is in operation, the outlet overpressure will be approximately 4" w.c. higher on single monitor operation than normal regulation set.

**E. Total lock-up.** If demand for gas downstream of regulator is zero, the sliding orifice (or orifices) will close against the secondary rubber monitor seat and lock-up the gas flow completely.

B838-IMRV Flow Chart		
	Inlet pressure (PSIG)	Flow SCFH
Vented gas flow, regulator seat failed, monitor seat closed	20	60
	40	90
	60	120
	75	150
	100	190
	125	230

B838 Inlet Effect Information (Change in outlet per 10 psi change in inlet)					
Spring Color	Orifice Size				
	3/8	1/2	5/8	3/4	7/8
Orange	0.22" w.c.	0.23" w.c.	0.33" w.c.	0.47" w.c.	0.98" w.c.
Brown	0.22" w.c.	0.23" w.c.	0.40" w.c.	0.50" w.c.	1.00" w.c.
Green/white	0.22" w.c.	0.23" w.c.	0.40" w.c.	0.50" w.c.	1.00" w.c.
Black	0.27" w.c.	0.29" w.c.	0.42" w.c.	0.55" w.c.	1.00" w.c.
Blue	0.01 PSIG	0.01 PSIG	0.01 PSIG	0.02 PSIG	0.03 PSIG
Silver	0.01 PSIG	0.01 PSIG	0.02 PSIG	0.02 PSIG	0.04 PSIG
Yellow	0.01 PSIG	0.02 PSIG	0.02 PSIG	0.03 PSIG	0.05 PSIG
Red	0.01 PSIG	0.02 PSIG	0.02 PSIG	0.03 PSIG	0.06 PSIG

**INTERNAL MONITOR CHARACTERISTICS**

Main Spring Color	Outlet Pressure Set	Internal Monitor Lockup B838 IMR and IMN	Relief Pressure of IMV B838 IMRV
Brown	5.5" w.c.	11.5" w.c.	15.0" w.c.
Green/white (for R)	7.0" w.c.	12.5" w.c.	17.0" w.c.
Brown (for N)			
Black	11.0" w.c.	17.0" w.c.	21.5" w.c.
Blue (for R)	14.0" w.c.	20.0" w.c.	27" w.c.
Black (for N)			
Blue	1 PSIG	1.6 PSIG	2.0 PSIG
Yellow	3 PSIG	3.8 PSIG	4.8 PSIG
Red	5 PSIG	6.0 PSIG	8.4 PSIG

**B838 IM CAPACITY TABLE, 2" X 2"**

Outlet Pressure	7" w.c.	7" w.c.	11" w.c.	11" w.c.	1 PSIG	2 PSIG	2 PSIG	2 PSIG	5 PSIG	5 PSIG	5 PSIG	
Pressure Droop	1" w.c.	1" w.c.	2" w.c.	2" w.c.	0.2 PSIG	1% ABS	2% ABS	WO	1% ABS	2% ABS	WO	
Orifice Size* (in inches)	Inlet Pressure PSIG	Flow rate, SCFH of .60 Wp. Gr. gas @ 14.7 PSIA and 60°F										
Loading Ring Setting	0°	20°	0°		0°	0°	0°	0°	0°	0°	0°	
1 K = 1830	1	2600	2250	2750	N.C.	3900						
	2	3650	3400	4400		5200	2700	4200	7480			
	3	5000	4850	5650		7450	4100	6500	12950			
	5	6200	6000	7500		10600	6200	10600	21140	3700	5600	18150
	10	6750	9100	10300		12700	8200	13600	26960	5000	7600	25670
	15	11300	11000	13450		19300	14750	17800	36330	7100	11000	36330
	25	19000	17800	20000		20000	18100	20000	40900	9800	14200	40900
	30		20000	20000								
Loading Ring Setting	0°	29°	0°	29°	0°	0°	0°	0°	0°	0°	0°	
3/4 K = 1400	1	2150	1900	2300	2000							
	2	3400	3050	3650	3400	3300						
	3	4000	3750	4600	4250	4300	2300	3500	5720			
	5	5700	5100	6250	6000	5800	3400	5400	9910			
	10	8000	7250	9600	9450	8950	5500	8600	16170	3600	5400	13890
	15	10200	9000	11500	11000	11400	6600	10600	20620	4700	7200	19640
	25	16850	15700	17700	16900	17600	10400	15600	27800	6900	9600	27800
	60	-	20000	-	20000	20000	20000	20000	52290	13100	18700	52290
Loading Ring Setting	0°	27°	0°	22°	0°	0°	0°	0°	0°	0°		
5/8 K = 1095	1	1750	1700	2000	1950							
	2	3600	2500	3200	3150	2750						
	3	3400	3200	4200	4050	3800	1800	2650	4480			
	5	5200	4800	5900	5650	5300	2750	4150	7750			
	10	7500	6900	9400	8750	8250	4500	7200	12650	3100	4500	10860
	15	9900	8800	11000	10050	10550	6200	9600	16130	4000	5900	15360
	25	15600	15200	16000	14900	15100	10300	14200	21570	6100	9200	21570
	60	-	20000	-	20000	20000	17800	20000	40900	12500	17800	40900

**B838 IM CAPACITY TABLE, 2" X 2"**

Outlet Pressure		7" w.c.	7" w.c.	11" w.c.	11" w.c.	1 PSIG	2 PSIG	2 PSIG	2 PSIG	5 PSIG	5 PSIG	5 PSIG
Pressure Droop		1" w.c.	1" w.c.	2" w.c.	2" w.c.	0.2 PSIG	1% ABS	2% ABS	WO	1% ABS	2% ABS	WO
Orifice Size* (in inches)	Inlet Pressure PSIG	Flow rate, SCFH of .60 Wp. Gr. gas @ 14.7 PSIA and 60°F										
		Loading Ring Setting										
Loading Ring Setting		0°	32°	0°	25°	0°	0°	0°	0°	0°	0°	0°
1/2 K = 790	1	1600	1550	1500	1450							
	2	2300	2250	2300	2250	2350						
	3	2900	2850	2900	2800	3050	1650	2300	3230			
	5	3800	3700	4050	3900	4150	2650	3500	5590			
	10	6600	5250	6500	5900	6600	4000	6300	9130	2600	3200	7840
	15	8100	6650	8500	7300	8500	5900	8000	11640	3600	4900	11080
	25	10900	8650	11900	10000	12000	9600	12600	15680	5300	7400	15680
	60	-	15900	-	19100	19500	16800	20000	29510	9400	14400	29510
	90	-	20000	-	20000	20000	20000	20000	41360	13700	18350	41360
125	-	20000	-	20000	20000	20000	20000	55180	19000	20000	55180	
Loading Ring Setting		0°	27°	0°	25°	0°	0°	0°	0°	0°	0°	0°
3/8 K = 600	1	1000	950	1200	1050							
	2	1700	1650	1950	1800	1700						
	3	2200	2150	2400	2300	2200	1300	1800	2800			
	5	3100	2900	3200	3100	3000	2000	2750	4250			
	10	4800	4400	5000	4600	4500	3200	4350	6930	2050	2650	5950
	15	6600	5600	6600	5800	5700	4000	6050	8840	2700	3550	8420
	25	10000	4800	10000	8200	8400	5050	8600	11910	3400	4800	11910
	60	17000	14000	17500	14400	17000	12000	17000	22410	6200	10200	22410
	90	-	18100	-	18400	20000	16300	20000	31410	7200	12400	31410
125	-	20000	-	20000	20000	20000	20000	41910	11300	18800	41910	

\* Both orifices wide open

N.C. No change needed in loading ring setting.

**B838 IM CAPACITY TABLE 2" X 3"**

Outlet Pressure		7" w.c.	7" w.c.	11" w.c.	11" w.c.	1 PSIG	2 PSIG	2 PSIG	2 PSIG	5 PSIG	5 PSIG	5 PSIG
Pressure Droop		1" w.c.	1" w.c.	2" w.c.	2" w.c.	0.2 PSIG	1% ABS	2% ABS	WO	1% ABS	2% ABS	WO
Orifice Size* (in inches)	Inlet Pressure PSIG	Flow rate, SCFH of .60 Wp. Gr. gas @ 14.7 PSIA and 60°F										
		Loading Ring Setting										
Loading Ring Setting		0°		0°		0°	0°	0°	0°	0°	0°	0°
1 K = 1900	1	2700		2900								
	2	4300		4500		4000						
	3	5650		6450		5700	3200	4900	7765			
	5	7400		8750		8100	5400	7800	13450			
	10	15300	N.C.	14900	N.C.	13100	8800	12700	20945	4500	6700	18150
	15	19600		19500		16800	11800	17000	27985	6160	9400	26655
	25	27000		27100		26400	16800	25000	37715	9400	14200	37715
	30	32000		32000		31700	22000	30000	42465	10100	16200	42465

**B838 IM CAPACITY TABLE 2" X 3"**

Outlet Pressure		7" w.c.	7" w.c.	11" w.c.	11" w.c.	1 PSIG	2 PSIG	2 PSIG	2 PSIG	5 PSIG	5 PSIG	5 PSIG	
Pressure Droop		1" w.c.	1" w.c.	2" w.c.	2" w.c.	0.2 PSIG	1% ABS	2% ABS	WO	1% ABS	2% ABS	WO	
Orifice Size* (in inches)	Inlet Pressure PSIG	Flow rate, SCFH of .60 Wp. Gr. gas @ 14.7 PSIA and 60°F											
		0°	40°		36°	0°	0°	0°	0°	0°	0°	0°	
3/4 K = 1440	1	2500	2300	N.C.	2550								
	2	3700	3100		4100	3300							
	3	4900	3850		5100	4400	2750	4100	5885				
	5	7000	5700		7050	6250	3700	5800	10190				
	10	10650	8700		10600	10400	6600	9900	16630	3700	5600	14285	
	15	31380	11800		14200	13500	8200	12700	21210	5000	7600	20205	
	25	-	18000		21000	20900	15000	20900	28585	7100	10500	28585	
	60	-	36000		36300	36300	34000	40000	53785	15500	24800	53785	
Loading Ring Setting		0°	38°	0°	34°	0°	0°	0°	0°	0°	0°		
5/8 K = 1140	1	1850	1800	2250	2100								
	2	3100	2600	3400	3300	2750							
	3	4000	3550	4400	4300	3800	2300	3500	4660				
	5	5700	4900	6000	5800	5300	3300	4800	8070				
	10	9400	7450	9450	9100	8250	4900	7800	13165	3200	4600	11310	
	15	12500	9300	12500	11650	19550	6800	10600	16790	4100	6000	15995	
	25	20000	17500	19700	19200	16100	10500	16300	22630	6200	9300	22630	
	60	-	35200	-	36100	35400	28700	34000	42850	13500	19600	42580	
Loading Ring Setting		0°	34°	0°	34°	0°	0°	0°	0°	0°	0°	0°	
1/2 K = 800	1	1600	1550	1500	1450								
	2	2300	2250	2300	2250	2350							
	3	2900	2850	3000	2800	3050	1650	2300	3470				
	5	4000	3700	4400	3900	4150	2650	3500	5660				
	10	6800	5850	6950	3650	6600	4000	6300	9240	3600	3200	7935	
	15	8500	6750	9000	7900	8500	5900	8000	11785	3700	4900	11225	
	25	14100	11400	13400	11600	12000	9600	12600	15880	5300	7400	15880	
	60	-	25700	-	25700	25700	20600	24000	29880	9400	14400	29880	
	90	-	34800	-	34800	34800	28000	33300	41880	13700	21300	41880	
	125	-	40000	-	40000	40000	35800	40000	55880	20200	29100	55880	
Loading Ring Setting		0°	32°	0°		0°	0°	0°	0°	0°	0°	0°	
3/8 K = 600	1	1000	950	1200									
	2	1700	1650	1950		1700							
	3	2200	2150	2400		2200	1450	1850	2800				
	5	3100	2900	3200		3000	2150	2850	4250				
	10	4950	4400	5000		4550	3500	4400	6930	2050	2650	5950	
	15	6600	5600	6600	N.C.	5850	4200	6100	8840	2700	3550	8420	
	25	10400	8900	10300		8850	6400	8800	11910	3450	4900	11910	
	60	21050	19200	21000		18800	14300	18200	22410	6800	10600	22410	
	90	-	27000	28200		26800	23200	26400	31410	10900	16800	31410	
	125	-	34000	35000		33000	29100	33200	41910	14200	22500	41910	

\* Both orifices are wide open

N.C. No change needed in loading ring setting.



**CAPACITY TABLE 2 X 4**

Outlet Pressure		7" w.c.	7" w.c.	11" w.c.	11" w.c.	1 PSIG	2 PSIG	2 PSIG	2 PSIG	5 PSIG	5 PSIG	
Pressure Drop		1" w.c.	1" w.c.	2" w.c.	2" w.c.	0.2 PSIG	1% ABS	2% ABS	WO	1% ABS	2% ABS	
Orifice Size* (in inches)	Inlet Pressure PSIG	Flow rate, SCFH of .60 Wp. Gr. gas @ 14.7 PSIA and 60°F										
		Loading Ring Setting		0°	25°	0°		0°	0°	0°	0°	0°
1	K = 1950	Loading Ring Setting		0°	25°	0°		0°	0°	0°	0°	0°
		1	2900	2800	2900							
		2	4600	4400	4550		4500					
		3	6500	6250	6700		5900	3300	5000	7970		
		5	9700	9000	9100	N.C.	8550	5450	7900	13800		
		10	16700	16100	16250		13800	8950	12900	22525	4650	6900
		15	22000	21000	21600		18000	12400	17700	28725	6300	9700
		25	31000	29800	31000		30300	20000	27300	38710	9700	14650
30	-	36000	37000		36100	24400	33000	43585	10400	16700		
Loading Ring Setting		0°	25°	0°	27°	0°	0°	0°	0°	0°	0°	
3/4	K = 1480	Loading Ring Setting		0°	25°	0°	27°	0°	0°	0°	0°	0°
		1	2700	2450		2850						
		2	4350	4250		4500	3450					
		3	5500	4950		6100	4600	2850	4200	6200		
		5	8200	7500	N.C.	8300	6500	3800	6100	10475		
		10	13900	11400		13950	10650	6900	10500	17095	3800	5800
		15	-	16900		18100	14500	8500	13700	21800	5150	7850
		25	-	26200		28000	23200	15000	21200	29380	7350	10800
60	-	48000		50000	46100	39700	47500	55280	16000	27800		
Loading Ring Setting		0°		0°		0°	0°	0°	0°	0°	0°	
5/8	K = 1175	Loading Ring Setting		0°		0°		0°	0°	0°	0°	0°
		1	2200		2300							
		2	3300		3500		3000					
		3	4200		4450		3900	2500	3400	4800		
		5	6100	N.C.	6300	N.C.	5450	3900	5400	8315		
		10	10100		10500		8600	5200	8000	13570	3300	4750
		15	13850		13500		11200	6900	10800	17310	4250	6200
		25	21500		21500		17400	11500	17200	23325	6400	9600
60	40000		40000		39200	30000	36200	43885	13900	21000		
Loading Ring Setting		0°	40°	0°		0°	0°	0°	0°	0°	0°	
1/2	K = 810	Loading Ring Setting		0°	40°	0°		0°	0°	0°	0°	0°
		1	1850	1600	1800							
		2	2600	2450	2850		2400					
		3	3350	3100	3500		3200	1750	2550	3700		
		5	4500	4150	5000		4250	3000	3900	5735		
		10	7450	6750	7400	N.C.	6700	4500	6400	9355	2650	3300
		15	9600	8550	9950		8600	6000	8200	11930	3800	5050
		25	14700	14400	14500		12450	9800	13000	16080	5450	7600
		60	-	23600	33000		29400	22200	27800	30255	9700	14850
		90	-	39800	40100		37900	35000	37000	42405	14100	21950
125	-	51200	52300		51500	45500	51000	56580	21000	30100		

**CAPACITY TABLE 2 X 4**

Outlet Pressure		7" w.c.	7" w.c.	11" w.c.	11" w.c.	1 PSIG	2 PSIG	2 PSIG	2 PSIG	5 PSIG	5 PSIG
Pressure Droop		1" w.c.	1" w.c.	2" w.c.	2" w.c.	0.2 PSIG	1% ABS	2% ABS	WO	1% ABS	2% ABS
Orifice Size* (in inches)	Inlet Pressure PSIG	Flow rate, SCFH of .60 Wp. Gr. gas @ 14.7 PSIA and 60°F									
		0°		0°		0°		0°		0°	
Loading Ring Setting		0°		0°		0°	0°	0°	0°	0°	0°
3/8  K = 600	1	1100		1200		2000					
	2	1750		2150							
	3	2300		3750		2400	1650	2150	2800		
	5	3150		3200		3250	2300	3400	4250		
	10	5050	N.C.	5100	N.C.	4850	3600	4500	6930	2050	2650
	15	6700		6700		6400	4300	6250	8840	2700	3550
	25	10600		10300		9050	6550	9000	11910	3450	4900
	60	22200		22000		20700	14500	18400	22410	6800	10600
	90	30500		30400		29300	25600	28300	31400	10900	16800
	125	35100		34900		35200	30000	34000	41910	14200	22500

\* Both orifices are wide open

N.C. No change needed in loading ring setting.

## B838 PERFORMANCE CURVES

### 7" w.c. Set Point

Type and model	B838 IMR
Inlet size	2" NPT
Outlet size	2" NPT
Orifice size	3/4"
Spring range	Green/white
Position no.	Horizontal

All test results are reported at a base of 14.7 PSIG at 60° F and with 0.6 S.G. gas.

#### Curves

- A 10 PSIG W.O.R.
- B 20 PSIG Set
- C 40 PSIG W.O.R.

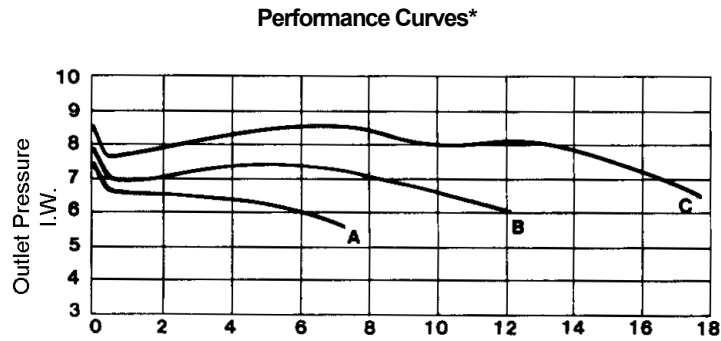

### 2 PSIG Set Point

Type and model	B838 IMR
Inlet size	2" NPT
Outlet size	2" NPT
Inlet pressure when set	
Orifice size	3/4"

Flow rate at set 500 SCFH

Spring Silver  
Position Horizontal  
Loading ring position 20°

All test results are reported at a base of 14.7 PSIG at 60° F and with 0.6 S.G. gas.

#### Curves

- A 10 PSIG W.O.R.
- B 20 PSIG Set
- C 40 PSIG W.O.R.

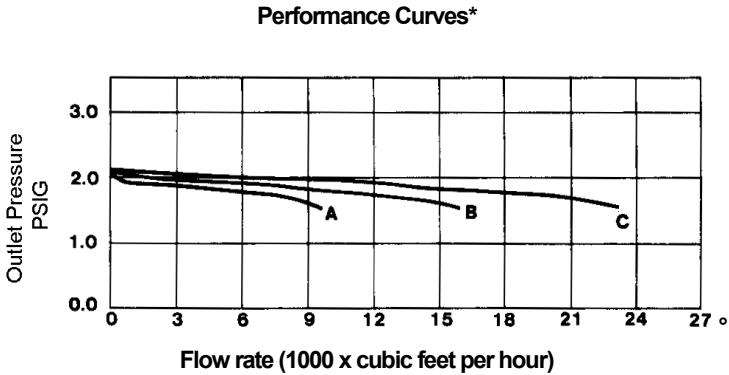

### 5 PSIG Set Point

Type and model	B838 IMR
Inlet size	2" NPT
Outlet size	2" NPT
Inlet pressure when set	20 PSIG
Orifice size	3/4"

Flow rate at set 500 SCFH  
Spring Red  
Position Horizontal

Loading ring position 0°

All test results are reported at a base of 14.7 PSIG at 60° F and with 0.6 S.G. gas.

#### Curves

- A 10 PSIG W.O.R.
- B 20 PSIG Set
- C 40 PSIG W.O.R.

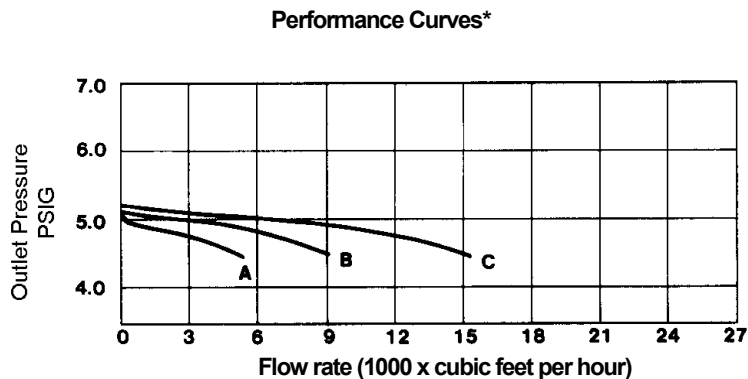

## B838 PERFORMANCE CURVES

### 7" w.c. Set Point<sup>1</sup>

Type and model	B838 IMR
Inlet size	2" NPT
Outlet size	2" NPT
Inlet pressure when set	20 PSIG
Orifice size	5/8"
Spring	Green/White
Position no.	A
Loading ring set at 27°	

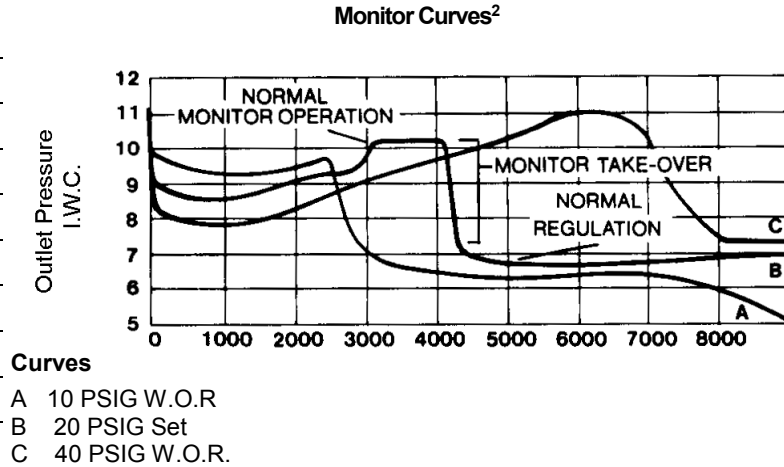

### 2 PSIG Set Point<sup>1</sup>

Type and model	B838 IMR
Inlet size	2" NPT
Outlet size	2" NPT
Inlet pressure at set	20 PSIG
Orifice size	5/8"
Spring	Silver
Position no.	A
Bolt circle diameter	12-1/16"
Loading ring set @ 0°	

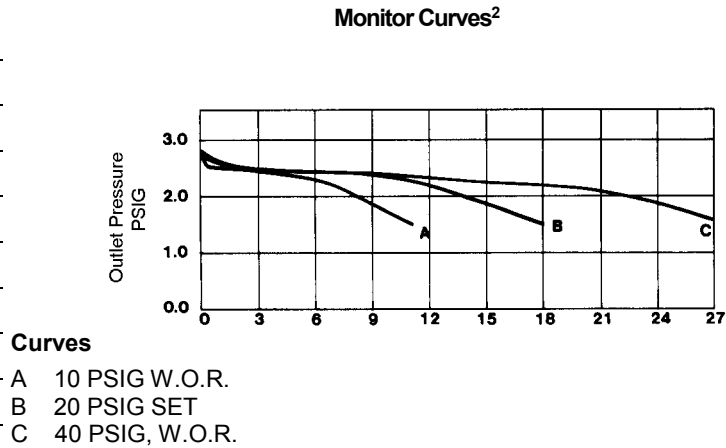

### 5 PSIG Set Point<sup>1</sup>

Type and model	B838 IMR
Inlet size	2" NPT
Outlet size	2" NPT
Inlet pressure at set	20 PSIG
Orifice size	5/8"
Spring	Red
Position no.	A
Bolt circle diameter	12-1/16"
Loading ring set @ 0°	

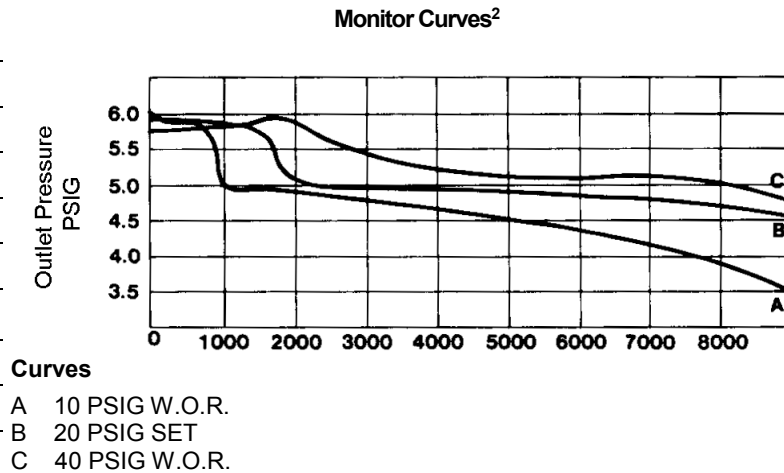

1. .125 diameter rod glued to one valve seat.
2. One regulator blocked wide open.

**B838 IMR RELIEF VALVE CHARACTERISTICS<sup>1</sup>**

**7" w.c. Set Point**

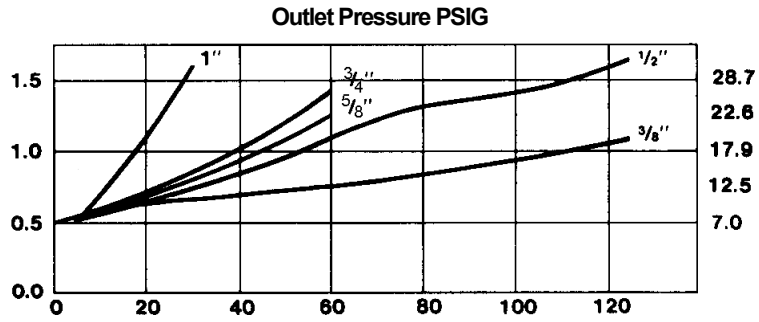

**2 PSIG Set Point**

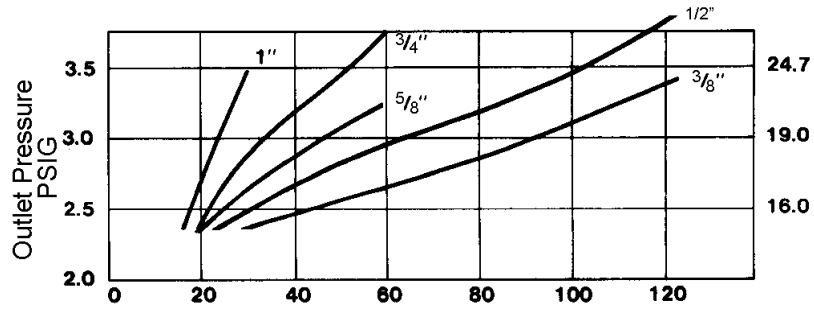

**5 PSIG Set Point**

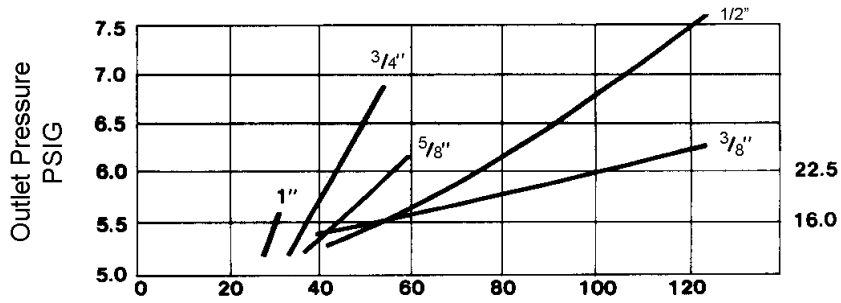

**Vented flow, SCFH x 1000**

**Inlet Pressure, PSIG**

<sup>1</sup>One valve seat blocked wide open per orifice size and foreign particle wedged between monitor sealing surfaces.

## ASSEMBLY POSITIONS

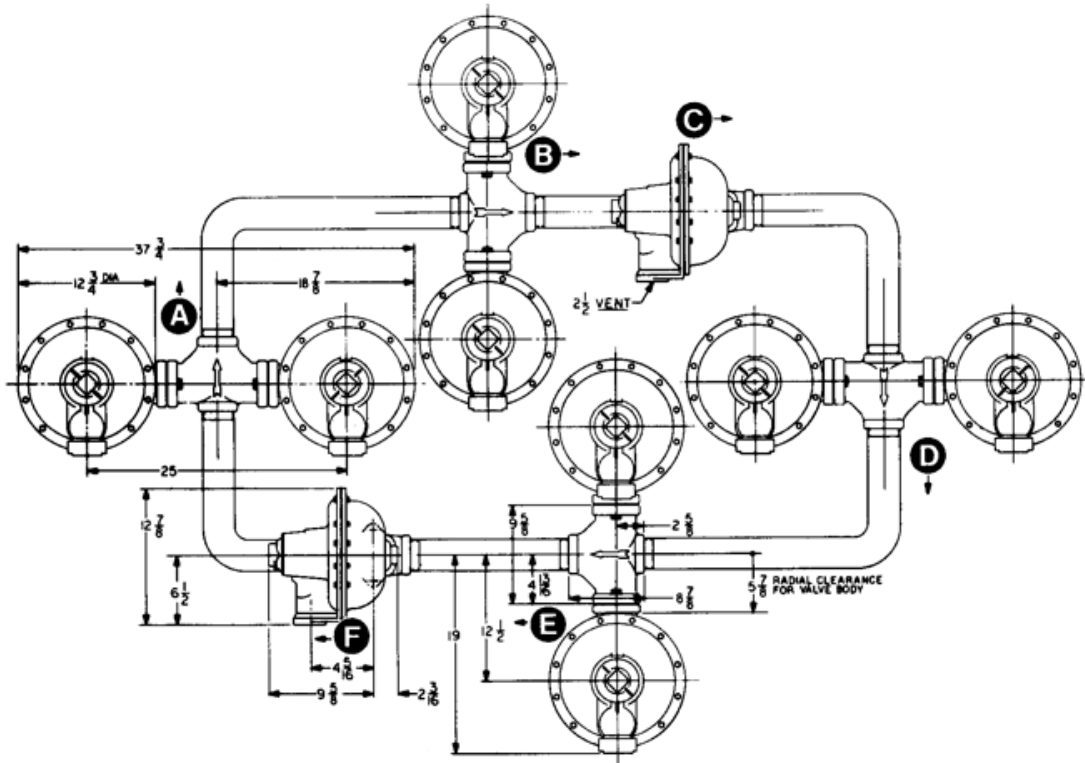

## PARTS LIST

### B838 R Twin Parallel Flow Regulator

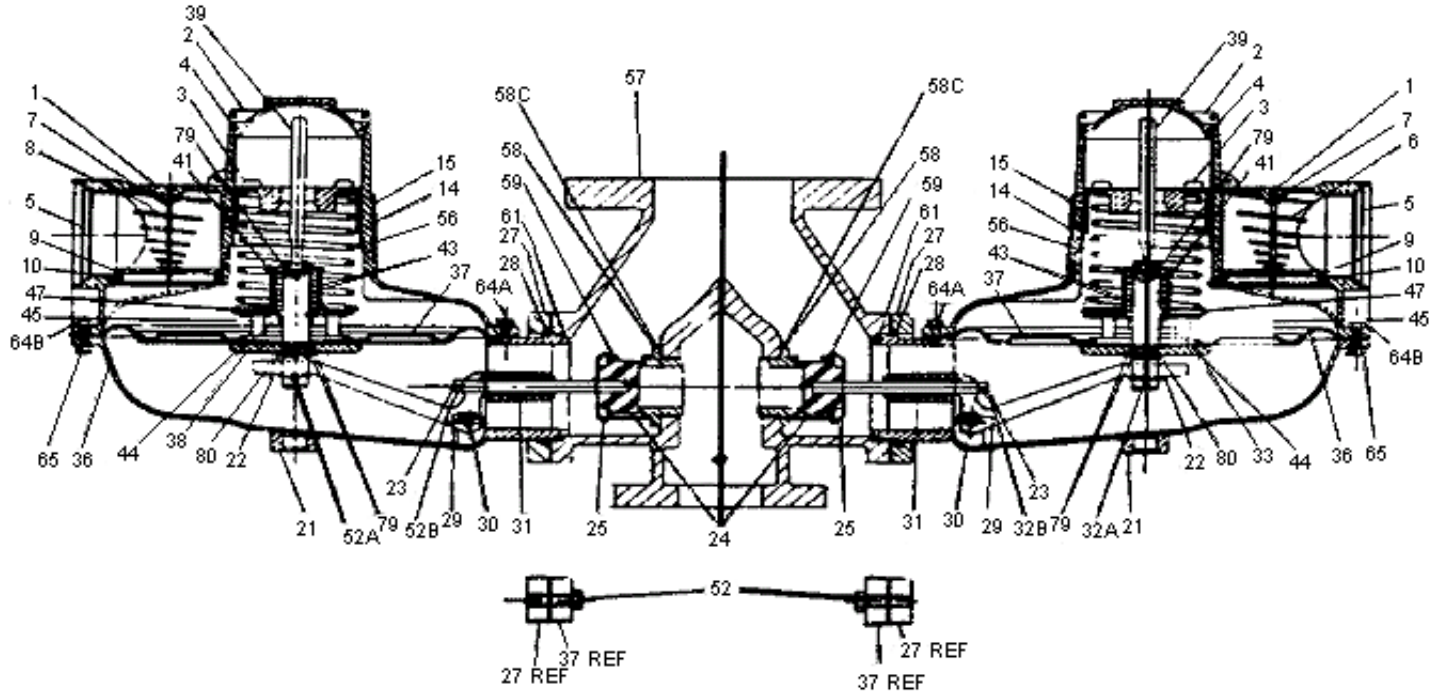

**B838 N Twin Parallel Flow Regulator**

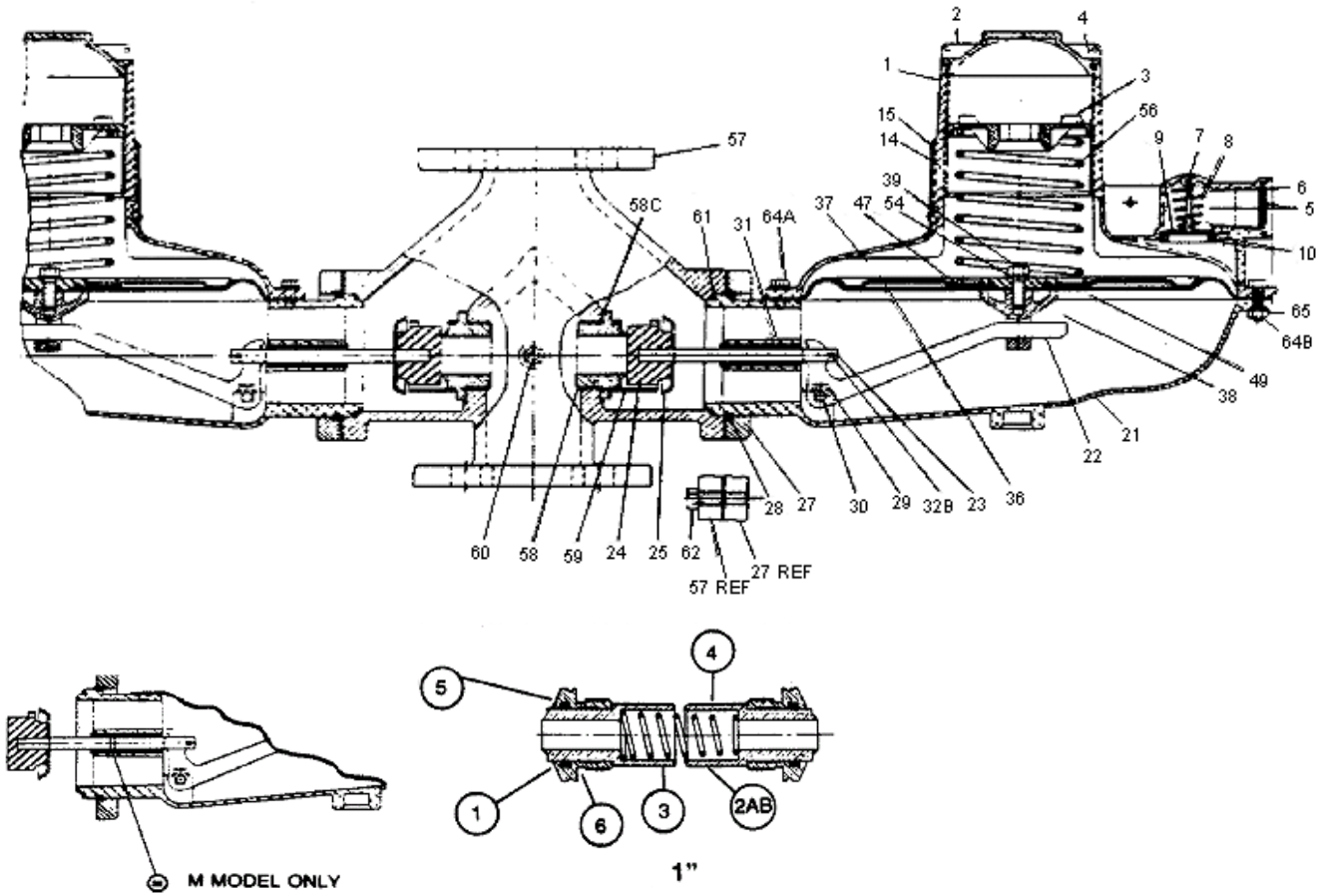

Item No.	Part No.	Quantity Required per Regulator Model						Description
		RD	RM	D	M	R	N	
1	753404	-	-	2	2	-	2	Upper diaphragm case, vent, 1" pipe
1A	753434	2	2	-	-	2	-	Upper diaphragm case, vent, 2-1/2" pipe
2	760083	2	2	2	2	2	2	Seal cap
3	760233	-	-	2	2	-	2	Adjustment screw
3A	760253							Adjustment screw
4	765607							Seal cap gasket
5	762933							Vent screen, 1" vent
5A	762941							Vent screen, 2-1/2" vent
6	75579102							Vent screen retainer ring, 1" vent
7	75483401							Vent valve disc pin, 1" vent
7A	754801							Vent valve disc pin, 2-1/2" vent
8	762651							Vent valve spring, 1" vent
8A	80000601							Vent valve spring, 2-1/2" vent
9	765181							Vent valve disc, 1" vent
9A	765343							Vent valve disc, 2-1/2"
10	765685							Vent valve seat, 1" vent
10A	761651							Vent valve seat, 2-1/2" vent
14	769241							Regulator badge
15	755071							Badge drive screw

Item No.	Part No.	Quantity Required per Regulator Model						Description
		RD	RM	D	M	R	N	
21								Lower diaphragm case
	715065							4:1 ratio, open throat
	715066							3.5:1 ratio, closed throat
22								Valve linkage lever
	761275							4:1 ratio standard
	761271							3.5:1 ratio
23								Valve stem
	754191							3/8" square
	754193							17/32" diamond without ring groove
24	765211							Valve seat, Buna N, 80 Durometer
25	761731							Deflector
27	751933							Valve body retainer plate
28	755721							Retainer, snap ring
29	755223							Valve linkage pin screw
30	754836							Valve linkage pin
33	765505							Valve stem O-ring
36	720103							Diaphragm/plate, relief
	720101							Diaphragm/plate, no relief
37	761091							Upper diaphragm plate
	76104101							Upper diaphragm plate
38								Lower diaphragm plate
	756075							No bead
	756081							With bead
39	755363							Stop Stem
	754385							Stop stem sub, assembly, self-aligning
	754381							Lower
	754383							Upper
	755739							Retaining ring (lower stem)
	765171							Disc (rubber)
41	761455							Relief spring guide
43	762423							Relief spring brown, standard
	762403							Relief spring, green
44	754941							Stop stem guide bushing
45	761671							Relief cap
47	761481							Adjustment spring guide
	761483							Adjustment spring guide
	755001							Roll pin, stop stem
	755007							3/32" diameter x 3/8" length
	755009							3/32" diameter x 1/2" length
54	755851							Diaphragm plate washer, lock
56		2	2	2	2	2	2	Adjustment spring, please specify
	762351							Brown
	762353							Green
	762355							Black
	762357							Blue
	762358							Blue/white
	762359							Silver



Item No.	Part No.	Quantity Required per Regulator Model						Description
		RD	RM	D	M	R	N	
<i>56 Adjustment spring continued</i>								
	762361							Yellow
	762671							Red (nested)
	762673							White (nested)
	762321							Green/white stripe
	762323							Silver/red
	762341							Orange
	762345							Orange/green
	762365							Purple
57		1	1	1	1	1	1	Valve body, please specify type and size: Straight
	750954							2" X 2" NPT
	750959							2 x 2 NPT with 1/8" NPT pipe plug
57								Flanged
	750965							2" x 2" ASA 10" face to face
	750969							2" x 2" ASA with 1/8 NPT pipe plug
	750974							2" x 3" ASA 10" face to face
	750975							2" x 3" ASA with 1/8 NPT pipe plug
	750984							2" x 4" ASA 10" face to face
	750985							2" x 4" ASA with 1/8 NPT pipe plug
	750989							2" x 4" ASA with 1/4 NPT outlet tap
58		2	2	2	2	2	2	Orifice, specify type and size: Straight, brass, 2-1/2" ext
	758371							.320" X 3/8"
	758372							1/4" X 3/8"
	758398							1/4"
	758401							1/2"
	758404							3/4"
	758407							1"
	758410							1-1/4"
	758413							1-3/8"
	758416							5/8"
	758419							3/8"
								IM orifice assemblies. See internal monitor orifice assembly parts lists
59	761771	2	2	2	2	2	2	Loading ring
60								Valve body pipe plug
	764431	See item #57 for required quantity						1/8" NPT, stainless steel
61	80001901	2	2	2	2	2	2	Valve body gasket
62	755391	4	4	4	4	4	4	Retainer plate screw, 3/8" , 16 X 1-5/16" hex head
62A	755393	4	4	4	4	4	4	Retainer plate screw, 3/8" 16 X 1-5/16" hex head, drilled
64B	755311-001	24	24	24	24	24	24	1/4-20 x 1" length steel, B34/B38 case screw, hex head
65	755513	20	20	20	20	20	20	Case screw nut
79	755711	6	6	-	-	6	-	Stop stem retainer ring, external
80	766521	2	2	-	-	2	-	O-ring lower diaphragm
91	765525	2	2	2	2	2	2	Orifice O-ring

Item No.	Part No.	Quantity Required per Regulator Model						Description
		RD	RM	D	M	R	N	
Subassemblies								
	710040	-	-	2	2	-	2	Upper diaphragm case, 1" vent, subassembly
	710045	2	2	-	-	2	-	Upper diaphragm case, 2 1/2" vent, subassembly
	715030	-	-	-	-	2	2	Lower diaphragm case subassembly
								Lower diaphragm case subassembly 3:5:1 ratio, closed
	715031	-	2	-	2	-	-	With valve stem O-ring
	715064	2	-	2	-	-	-	Without valve stem O-ring
	720029	-	-	2	2	-	2	Diaphragm subassembly, no relief
	720033	2	2	-	-	2	-	Diaphragm subassembly, relief, standard
	720034	2	2	-	-	2	-	Diaphragm subassembly, relief, green relief spring

## INTERNAL MONITOR ORIFICE ASSEMBLY PARTS LISTS

### 3/8" and 1/2" Orifice Components

Item No.	Description	Part No.
1	Stationary orifice	758437
2A	3/8" Sliding orifice (male)	758471
2B	3/8" Sliding orifice with vent hole (male)	758474
2A	1/2" sliding orifice (male)	758477
2B	1/2" Sliding orifice with vent hole (male)	758480
3	3/8" Sliding orifice (female)	759151
3	1/2" Sliding orifice (female)	759153
4	Cut-off spring (red)	762451
5	O-ring	765531
6	O-ring	765525

Note: components are interchangeable.

### 5/8" and 3/4" Orifice Components

Item No.	Description	Part No.
1	Stationary orifice	758434
2A	5/8" Sliding orifice (male)	758484
2B	5/8" Sliding orifice with vent hole (male)	758487
2A	3/4" Sliding orifice (male)	758490
2B	3/4" Sliding orifice with vent hole (male)	758493
3	5/8" Sliding orifice (female)	759155
3	3/4" Sliding orifice (female)	759157
4	Cut-off spring (blue)	762453
5	O-ring	765533
6	O-ring	765525

Note: components are interchangeable.

## 1" Orifice Components

Item No.	Description	Part No.
1	Stationary orifice	758431
2A	1" Sliding orifice (male)	758497
2B	1" Sliding orifice w vent hole (male)	758498
3	1" Sliding orifice (female)	759159
4	Cut - off spring (yellow)	762455
5	O-ring	765523
6	O-ring	765525

## IMN and IMR Orifice Assembly, Complete

Item	Description	Part No.
58A	3/8" diameter	759161
	1/2" diameter	759165
	5/8" diameter	759171
	3/4" diameter	759175
	1" diameter	759181

## IMRV Orifice Assembly, Complete

Item	Description	Part No.
58B	3/8" diameter	759163
	1/2" diameter	759167
	5/8" diameter	759173
	3/4" diameter	759177
	1" diameter	759183

Note: 1" components are not interchangeable with other sizes.

## Special Tools

Description	Part No.
Machined orifice wrench	799027
Adjustment wrench	799055
Seal wire, no lead, 24	80002002

Notes:

- B838 IMN parts are identical to B838 N parts except for the orifice assembly.
- B838 IMR parts are identical to B838 R parts except for the orifice assembly.
- B838 IMRV parts are identical to B838 R parts except for the orifice assembly.

## Torque Specifications

Retainer Plate Screws	100 in. lbs.
Orifice	600 in. lbs.
Orifice (IM)	300 in. lbs.
Margin screws (item no.648)	50 in. lbs.
Margin screws (item no. 64A)	30 in. lbs.

## VENT LINES FOR REGULATORS

If you are constructing vent lines to be attached to regulators installed indoors, follow a few basic rules:

- a. Never use pipe sizes smaller than the vent size; smaller pipe sizes restrict the gas flow. If a long gas run must be used, Itron advises increasing the pipe one nominal size every ten feet to keep the flow restriction as low as possible.
- b. Keep the vent line length as short as possible to minimize the restriction and reduce the vent's tendency to cause regulator pulsation.
- c. Support the vent pipe to eliminate strain on the regulator diaphragm case.
- d. Always point outdoor vent pipes in the downward position to reduce the possibility of rain, snow, sleet, and other moisture entering the pipe. Install a bug screen in the end of the pipe.
- e. Do not locate the vent line terminus near windows, fans, or other ventilation equipment. See the installation instructions furnished with the regulator.
- f. Adhere to all applicable codes and regulations.
- g. If your vent pipe causes regulator pulsation, consult your sales representative or manufacturer.
- h. Itron strongly recommends running a separate vent line for each regulator. Headers with various installed devices can cause regulator malfunction.

---

**Caution** Ensure the end of the vent line is away from ANY potential ignition sources. It is the installer's responsibility to verify the vent line is exhausting to a safe environment.

---

## INSTALLATION

---

**Warning** Itron does not endorse or warrant the completeness or accuracy of any third party regulator installation procedures or practices, unless otherwise provided in writing by Itron. Follow your company's standard operating procedures regarding the use of personal protection equipment (PPE). Adhere to guidelines issued by your company in addition to those given in this document when installing regulators.

---

- a. Remove all shipping plugs from the regulator inlet, outlet, and vent before installation.
- b. Verify the piping interior and regulator inlet and outlet are clean and free of dirt, pipe dope, and other debris. Dirt and other foreign materials entering the regulator can cause a loss of pressure control.
- c. Apply pipe joint sealant to the male pipe threads. Do not use pipe joint material on the regulator's female threads. Joint sealant could become lodged in the regulator and cause a loss of pressure control.
- d. Gas must flow through the regulator's valve body in the direction cast on the regulator body. Gas flowing in the wrong direction can overpressure and cause damage to the regulator.
- e. The pilot diaphragm casing can be mounted in any position relative to the body through a full 360° angle at 90° increments.
- f. When the regulator is installed OUTDOORS, the vent must always be positioned so that rain, snow, moisture or foreign particles cannot enter the vent opening. Itron recommends positioning the pilot vent downward to avoid entry of water or other matter which could interfere with the proper operation of the regulator. The vent should be located away from building eaves, window openings, building air intakes and above the expected snow level at the site. The vent opening should be inspected periodically to insure it does not become blocked by foreign material as outlined in DOT PHMSA-RSPA-2004-19856.
- g. When the regulator is installed INDOORS, the vent must be piped to the outside atmosphere using the shortest length of pipe, the fewest possible pipe elbows, and a pipe diameter as large as the vent size or larger. USING VENT PIPE SMALLER THAN THE VENT CONNECTION LIMITS THE REGULATOR'S INTERNAL RELIEF VALVE CAPACITY. The outlet end of the pipe must be protected from moisture and the entrance of foreign particles. The regulator should be specified by the user with the size vent and pipe threads desired to make the vent pipe connection.

## START-UP AND ADJUSTMENT

- h. Mount a pressure gauge downstream of the regulator to monitor the downstream pressure.
- i. With the downstream pressure valve closed, slowly open the inlet valve. The outlet pressure should rise to slightly more than the set-point. Verify there are no leaks and all connections are tight.
- j. The regulator was pre-set at the factory to match order specifications. If regulator readjustments are necessary, the adjustment is made to the main case springs. While the regulator is under steady flow conditions of 500 cfm or more, remove the main case seal caps.
- k. To increase outlet pressure, turn each adjustment screw clockwise in equal increments until the outlet pressure is about 10% below desired gauge pressure. Adjust one screw clockwise to desired outlet pressure. Turn the second screw clockwise until a slight increase in outlet pressure is observed. Make slight counterclockwise adjustments to achieve the desired outlet pressure. Both cases should always be set at the same pressure to keep both valves operating in unison.
- l. To decrease outlet pressure, turn each adjustment screw counterclockwise in equal increments until the outlet pressure is about 10% below desired outlet pressure. Adjust one screw clockwise to desired outlet pressure. Turn the second screw clockwise until a slight increase in outlet pressure is observed. Make slight counterclockwise adjustments to achieve the desired outlet pressure. Both cases should always be set at the same pressure to keep both valves operating in unison.
- m. Replace the seal caps and check for leaks after the desired outlet pressure is achieved.

The regulator is ready for operation.

## SAFETY WARNING

This product, as of the date of manufacture, is designed and tested to conform to all governmental and industry safety standards as they may apply to the manufacturer. The purchaser/user of this product must comply with all fire control, building codes, and other safety regulations governing the application, installation, operation, and general use of this regulator to avoid leaking gas hazards resulting from improper installation, startup or use of this product.

Itron strongly recommends installation by a qualified professional and periodic inspection of pressure regulators (inspections may be required by local applicable codes or regulations).

Inspections should include checking for gas quality, cycle numbers, external environmental changes, and operating conditions that impact wear on the regulator's moving parts. To ensure safe and efficient operation of this product, replace worn or damaged parts found during inspection.

## Limited Warranty

Itron, Inc. 2111 North Molter Road Liberty Lake, WA 99019, warrants this gas product against defects in materials and workmanship for the earlier of one (1) year from the date the product is shipped by Itron or a period of one year from the date the product is installed by Itron at the original purchaser's site. During such one-year period, provided that the original purchaser continues to own the product, Itron will, at its sole option, repair any defects, replace the product or repay the purchase price.

» This warranty will be void if the purchaser fails to observe the procedures for installation, operation or service of the product as set forth in the Operating Manual and Specifications for the product or if the defect is caused by tampering, physical abuse or misuse of the product.

- » ITRON SPECIFICALLY DISCLAIMS ALL IMPLIED WARRANTIES INCLUDING THOSE OF MERCHANTABILITY OR OF FITNESS FOR A PARTICULAR PURPOSE. UNDER NO CIRCUMSTANCES WILL ITRON BE LIABLE FOR INCIDENTAL OR CONSEQUENTIAL DAMAGES OF ANY KIND WHATSOEVER.
- » Itron's liability for any claim of any kind, including negligence and breach of warranty for the sale and use of any product covered by or furnished, shall in no case exceed the price allocable to the product or part thereof which gives rise to the claim.
- » In the event of a malfunction of the product, consult your Itron Service Representative or Itron Inc., 2111 North Molter Road Liberty Lake, WA 99019. See Itron Terms and Conditions of Sale for the full and complete terms of the Limited Warranty.

## Ordering Information

Specify:

1. Inlet and Outlet Connection Size and Type
2. Model Number
3. Outlet pressure desired
4. Pilot needed
5. Inlet pressure range
6. Type of gas and maximum capacity required
7. Assembly position number (see chart below)
8. Special requirements such as tagging, 1/8" pipe plug tap, seal wire, etc.



Join us in creating a more **resourceful world**.  
To learn more visit **itron.com**

### CORPORATE HQ

2111 North Molter Road  
Liberty Lake, WA 99019 USA

**Phone:** 1.800.635.5461

**Fax:** 1.509.891.3355