



High Current SHEV Fuses

High Current SHEV Fuse

The HC HEV fuse is designed for protection of high-current / high-voltage circuits in electric and hybrid electric vehicles employing an industry-standard footprint. The HC HEV fuse provides time-delay characteristics with "Diffusion Pill Technology."

Specifications

Interrupting Rating:	10KA @ 450VDC
Voltage Rating:	450VDC
Operating Temperature Range:	-40°C to +125°C
Net Weight Per Fuse:	30±5 gr
Material:	Body: Melamine (U.L. Flammability rating of 94 V0) End Caps: Stainless Steel Terminals: Copper Alloy
Recommended Mounting Torque:	5-7 Nm M6 (ISO prescription) 10 Nm M6 (Max allowed)
Refers To:	ISO 8820-8 first edition 2012-08-01 (Type J2) - JASO D622

Ordering Information

Part Number	Termination	Package Size
SHEVxxx.ZXBD	M6 Bolt Down	320

Time-Current Characteristics

% of Rating	Opening Time Min / Max (s)
110	4 hrs / ∞
200	1.0 / 300
300	0.2 / 30
500	0.05 / 1.0

Time-Current Characteristic Curves

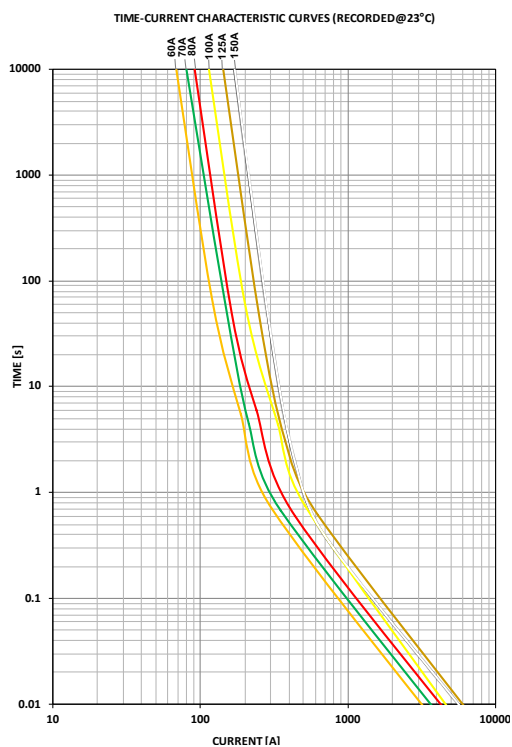

Ratings

Part Number	Current Rating (A)	Typ. Voltage Drop (mV)	Max. Voltage Drop Spec at 100% IR (mV)	Cold Resistance (mΩ)	Minimum Melting I ² t (A ² s)
SHEV060.ZXBD	60	110	200	1.4	7745
SHEV070.ZXBD	70 (*)	115	200	1.2	Coming up
SHEV080.ZXBD	80	90	200	0.8	16002
SHEV100.ZXBD	100	95	200	0.62	27079
SHEV125.ZXBD	125 (*)	95	200	0.48	Coming up
SHEV150.ZXBD	150 (*)	140	200	0.48	Coming up

(*) Products in development - please contact Littelfuse® for more details regarding availability timing. Final values for voltage drop, resistance, melting I²t and T/C curves will be generated from PV tests data

Dimensions

Dimensions in mm

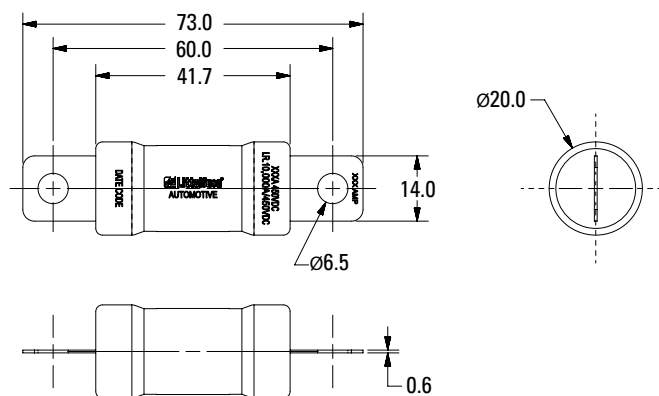

REV11072019

Littelfuse products are not designed for, and shall not be used for, any purpose (including, without limitation, automotive, military, aerospace, medical, life-saving, life-sustaining or nuclear facility applications, devices intended for surgical implant into the body, or any other application in which the failure or lack of desired operation of the product may result in personal injury, death, or property damage) other than those expressly set forth in applicable Littelfuse product documentation. Warranties granted by Littelfuse shall be deemed void for products used for any purpose not expressly set forth in applicable Littelfuse documentation. Littelfuse shall not be liable for any claims or damages arising out of products used in applications not expressly intended by Littelfuse as set forth in applicable Littelfuse documentation. The sale and use of Littelfuse products is subject to Littelfuse Terms and Conditions of Sale, unless otherwise agreed by Littelfuse.